

# **GEORGIA HIGH SCHOOL ASSOCIATION**

---

VOL. 117

NUMBER 1

---

## **CONSTITUTION and BY-LAWS 2023-2024**

*A Member of the National Federation of  
State High School Associations*



151 South Bethel Street  
Thomaston, Georgia 30286-0004  
706-647-7473  
FAX 706-647-2638  
[www.ghsa.net](http://www.ghsa.net)

*North*

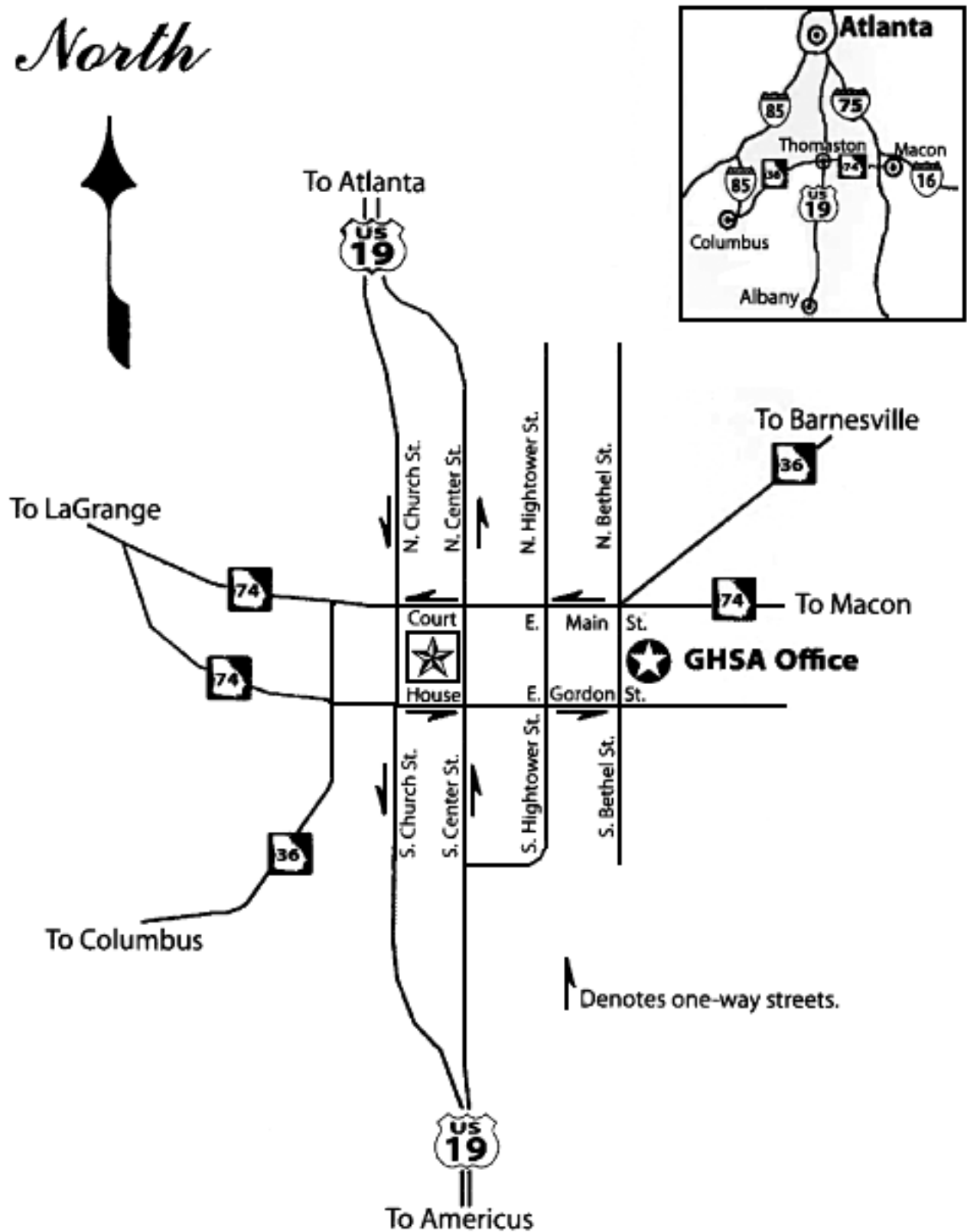

Directions to the Georgia High School Association Office,  
151 S. Bethel Street, Thomaston, Georgia

**GEORGIA HIGH SCHOOL ASSOCIATION  
BEGINNING AND ENDING DATES FOR 2023-2024**

Revised  
10/11/23

| ACTIVITY                       | DATE FOR FIRST PRACTICE | FIRST CONTEST     | MAXIMUM GAMES/DATES | LAST PLAY DATE     | PLAYOFF QUALIFIERS DETERMINED | GHSA STATE PLAYOFF DATES   |                |                |               |   |  |
|--------------------------------|-------------------------|-------------------|---------------------|--------------------|-------------------------------|----------------------------|----------------|----------------|---------------|---|--|
|                                |                         |                   |                     |                    |                               | First Round/<br>Sectionals | Second Round   | Quarterfinals  | Semifinals    | Finals  |  |
| FOOTBALL                       | July 31                 | Aug. 18           | 10 (7 JV)           | Nov. 3             | Nov. 3                        | Nov. 10-11                 | Nov. 17        | Nov. 24        | Dec. 1        | Dec. 11-13                                      |  |
| CHEERLEADING GAME DAY          | July 31<br>July 31      | Aug. 5<br>Sept. 5 | 6 (4 JV)<br>-       | Oct. 28<br>Dec. 2  | Nov. 4<br>Dec. 2              | Nov. 4                     |                |                |               | Nov. 10-11<br>Dec. 8                            |  |
| SOFTBALL (FP)<br>SOFTBALL (SP) | July 31<br>Feb. 12      | Aug. 4<br>Feb. 15 | 30 (21 JV)<br>16    | Oct. 12<br>April 6 | Oct. 12<br>April 6            | Oct. 16-19<br>April 10     | Oct. 16-19     |                | Oct. 25-27    | Oct. 28<br>April 17-18                          |  |
| VOLLEYBALL                     | July 31                 | Aug. 7            | 18 (13 JV) Dates    | Oct. 14            | Oct. 14                       | Oct. 17-18                 | Oct. 21        | Oct. 24-25     | Oct. 28       | Nov. 3-4  |  |
| CROSS COUNTRY                  | July 31                 | Aug. 7            | 10 (7 JV) Dates     | Oct. 28            | Oct. 28                       |                            |                |                |               | Nov. 3-4  |  |
| FLAG FOOTBALL                  | Sept. 11                | Oct. 2            | 10 (7 JV) Dates     | Nov. 30            | Nov. 30                       | Dec. 5                     | Dec. 5         | Dec. 7         | Dec. 7        | Dec. 11-13                                      |  |
| ONE ACT PLAYS                  | July 31                 | -                 | -                   | Oct. 28 & Nov. 4   | Oct. 28 & Nov. 4              |                            |                |                |               | Nov. 11 & 18                                    |  |
| LITERARY                       | July 31                 | -                 | -                   | March 9            | March 9                       |                            |                |                |               | March 16 & 23                                   |  |
| RIFLERY                        | July 31                 | Oct. 23           | -                   | Feb. 13            | Feb. 13                       | Feb. 26                    |                |                | March 5       | March 16  |  |
| SWIMMING                       | Oct. 9                  | Oct. 23           | 10 (7 JV)           | Feb. 2             |                               |                            |                |                |               | Feb. 6-7, 9-10                                  |  |
| DANCE                          | Oct. 23                 | Nov. 4            | 6 (4 JV)            | Feb. 3             |                               |                            |                |                |               | Feb. 10   |  |
| BASKETBALL                     | Oct. 23                 | Nov. 10           | 25 (18 JV)          | Feb. 17            | Feb. 17                       | Feb. 20-21                 | Feb. 23-24     | Feb. 27-28     | March 1-2     | March 6-9                                       |  |
| WRESTLING                      | Oct. 23                 | Nov. 10           | 20 (14 JV) Dates    | Feb. 3             | Du - Jan. 13<br>Tr - Feb. 2-3 | Tr - Feb. 9-10             |                |                |               | Dual - B Jan. 19-20; G 26-27<br>Tr - Feb. 15-17 |  |
| GYMNASTICS                     | Jan. 8                  | Jan. 22           | 10 (7 JV)           | April 10           |                               | April 17-19                |                |                |               | April 19  |  |
| TENNIS                         | Jan. 8                  | Jan. 22           | 18 (13 JV) Dates    | April 11           | April 11                      | By April 18                | By April 24    | By April 30    | By May 6      | May 11  |  |
| SOCCER                         | Jan. 15                 | Feb. 5            | 18 (13 JV)          | April 13           | April 13                      | April 16-19                | April 23-26    | April 29-30    | May 2-3       | May 7-10  |  |
| TRACK & FIELD                  | Jan. 8                  | Feb. 5            | 10 (7 JV)           | April 27           | April 27                      | May 4                      |                |                |               | May 9-11  |  |
| LACROSSE                       | Jan. 15                 | Feb. 5            | 18 (13 JV)          | April 20           | April 20                      | April 23-24                | April 26-27    | April 30-May 1 | May 3-4       | May 9-11  |  |
| BASEBALL                       | Jan. 15                 | Feb. 12           | 30 (21 JV)          | April 20           | April 20                      | April 23-26                | April 29-May 2 | May 4, 6-7     | May 10-11, 13 | May 16-18, 20-23                                |  |
| GOLF                           | Jan. 31                 | Feb. 17           | 12 (8 JV) Dates     | May 11             | May 6<br>April 29 (5-7A)      | May 6-7 (5-7A)             |                |                |               | May 20-21                                       |  |

NOTES: Dates and more information for Bass Fishing and Esports may be found on the GHSA web site ([www.ghsa.net](http://www.ghsa.net)).  
The "Dead Weeks" for the 2023-24 school year are Monday, May 27 through Sunday, June 2, 2024 and Monday, July 1 through Sunday, July 7, 2024. The GHSA office will be closed both weeks.

# GHSA DEADLINE DATES - 2023-24

| <u>Due Date</u>             | <u>Material to be Submitted</u>                              | <u>Sent To</u>   |
|-----------------------------|--|------------------|
| July 24, 2023               | Initial Eligibility Report Due - Football                    | GHSA             |
| July 31, 2023               | Initial Eligibility Report Due - Cheerleading & GameDay      | GHSA             |
| July 31, 2023               | Initial Eligibility Report Due - Cross Country               | GHSA             |
| July 31, 2023               | Initial Eligibility Report Due - One Act Play                | GHSA             |
| July 31, 2023               | Initial Eligibility Report Due - Literary                    | GHSA             |
| July 31, 2023               | Initial Eligibility Report Due - Riflery                     | GHSA             |
| July 31, 2023               | Initial Eligibility Report Due - Fast Pitch Softball         | GHSA             |
| July 31, 2023               | Initial Eligibility Report Due - Volleyball                  | GHSA             |
| August 1, 2023              | Directory & Pass Information Due (Post Electronically)       | GHSA             |
| September 11, 2023          | Initial Eligibility Report Due - Flag Football               | GHSA             |
| October 1, 2023             | Notification of Entry - One Act Play                         | GHSA             |
| October 1, 2023             | Final Date to Withdraw from Coed Cheerleading                | GHSA             |
| October 1, 2023             | Notice of Entry - Cheerleading (Post Rosters Electronically) | GHSA/Reg. Sec.   |
| October 9, 2023             | Initial Eligibility Report Due - Swimming                    | GHSA             |
| <del>October 15, 2023</del> | <del>Membership Dues Form &amp; Payment Deadline</del>       | <del>GHSA</del>  |
| October 23, 2023            | Initial Eligibility Report Due - Dance                       | GHSA             |
| October 23, 2023            | Initial Eligibility Report Due - Basketball                  | GHSA             |
| October 23, 2023            | Initial Eligibility Report Due - Wrestling                   | GHSA             |
| January 8, 2024             | Initial Eligibility Report Due - Gymnastics                  | GHSA             |
| January 8, 2024             | Initial Eligibility Report Due - Tennis                      | GHSA             |
| January 8, 2024             | Initial Eligibility Report Due - Boys & Girls Track          | GHSA             |
| January 15, 2024            | Initial Eligibility Report Due - Soccer                      | GHSA             |
| January 15, 2024            | Initial Eligibility Report Due - Baseball                    | GHSA             |
| January 15, 2024            | Initial Eligibility Report Due - Lacrosse                    | GHSA             |
| January 31, 2024            | Initial Eligibility Report Due - Golf                        | GHSA             |
| February 1, 2024            | Contestants List - Literary (Post Electronically)            | GHSA             |
| February 12, 2024           | Initial Eligibility Report Due - Slow Pitch Softball         | GHSA             |
| March 1, 2024               | Notice of Intent to participate in all sports (2024-25)      | GHSA             |
| March 1, 2024               | Football Schedules Due                                       | GHSA             |
| April 1, 2024               | Participation Survey Due                                     | GHSA             |
| April 15, 2024              | Golf Contestants List Due (Post Electronically)              | GHSA             |
| End Regular Season          | Contestants List - Cross Country (Post Electronically)       | Region Secretary |
| End Regular Season          | Contestants List - Boys & Girls Track                        | Region Secretary |
| End Regular Season          | Tennis Roster & Playoff Lineup (Post Electronically)         | GHSA             |

# TABLE OF CONTENTS

|  |     |
|--|-----|
| GHSA CONSTITUTION.....   | 7   |
| BY-LAW SECTION 1.00 - STUDENT.....   | 14  |
| By-Law 1.10 - Certification of Eligibility.....  | 14  |
| By-Law 1.20 - Enrollment and Team Membership.....  | 14  |
| By-Law 1.30 - Age.....   | 15  |
| By-Law 1.40 - Limits of Participation.....   | 15  |
| By-Law 1.50 - Scholastic Standing / Scholarship.....                                     | 16  |
| By-Law 1.60 - School Service Areas / Transfer / Migrant Student.....                     | 19  |
| By-Law 1.70 - Recruiting / Undue Influence.....  | 22  |
| By-Law 1.80 - Financial Aid.....   | 22  |
| By-Law 1.90 - Amateur Status / Awards.....   | 23  |
| BY-LAW SECTION 2.00 - SCHOOL.....  | 23  |
| By-Law 2.10 - School Membership to GHSA.....   | 23  |
| By-Law 2.20 - Administrative Responsibilities.....                                       | 24  |
| By-Law 2.30 - Eligibility Reports Filed By The School.....                               | 25  |
| By-Law 2.40 - Student Retention for Athletic Activities.....                             | 26  |
| By-Law 2.50 - Qualifications to Coach.....   | 26  |
| By-Law 2.60 - Interscholastic Contests and Practices (Heat and Concussion policies)..... | 27  |
| By-Law 2.70 - Sportsmanship.....   | 33  |
| By-Law 2.80 - Media and Filming Regulations.....   | 35  |
| By-Law 2.90 - Regulations of Competitions.....   | 37  |
| BY-LAW SECTION 3.00 - REGION.....  | 38  |
| By-Law 3.10 - Region Authority.....  | 38  |
| By-Law 3.20 - Region Responsibilities to State Association.....                          | 39  |
| By-Law 3.30 - Region Financial Obligations to State Association.....                     | 39  |
| BY-LAW SECTION 4.00 - STATE.....   | 39  |
| By-Law 4.10 - GHSA Administrative Responsibilities to Member Schools.....                | 39  |
| By-Law 4.20 - Reclassification.....  | 40  |
| By-Law 4.30 - State Association Contest / Event Responsibilities.....                    | 42  |
| By-Law 4.40 - State Passes to GHSA Events.....   | 43  |
| By-Law 4.50 - Certification of Athletic Officials.....                                   | 44  |
| By-Law 4.60 - Special GHSA Policies.....   | 46  |
| ATHLETICS AND ACTIVITIES.....  | 48  |
| Baseball.....  | 48  |
| Basketball.....  | 50  |
| Bass Fishing.....  | 53  |
| Cheerleading (including Game Day Cheerleading).....                                      | 54  |
| Cross Country.....   | 58  |
| Dance.....   | 59  |
| Football (including Flag Football).....  | 61  |
| Golf.....  | 68  |
| Gymnastics.....  | 71  |
| Lacrosse.....  | 72  |
| Riflery.....   | 74  |
| Soccer.....  | 76  |
| Softball (including Slow Pitch).....   | 78  |
| Swimming and Diving.....   | 81  |
| Tennis.....  | 84  |
| Track and Field.....   | 87  |
| Volleyball.....  | 90  |
| Wrestling.....   | 92  |
| Esports.....   | 96  |
| Literary.....  | 97  |
| One Act Play.....  | 103 |
| APPENDIX A: Alliance of GHSA and AAASP   |     |
| APPENDIX B: Brackets for All State Playoffs  |     |
| APPENDIX C: GHSA Officers and Executive Committee  |     |
| APPENDIX E: Eligibility Report Instructions  |     |
| APPENDIX F: Fee Chart for Officials  |     |
| APPENDIX P: Fines Structure for Rules Violations   |     |
| APPENDIX R: Reclassification Numbers and Alignment for 2023-24 School Year               |     |
| APPENDIX S: Service Areas for Non-Public Member Schools                                  |     |
| APPENDIX Z: Results and Records from 2022-23 School Year                                 |     |

NOTE: Text printed in *italic* throughout this publication is **new or modified** material for this year.

This page intentionally left blank

# CONSTITUTION

## ARTICLE I - NAME OF THE ORGANIZATION

This organization shall be known as the Georgia High School Association.

## ARTICLE II - OBJECT OF THE ORGANIZATION

The objective of the organization shall be the promotion of education in Georgia from a mental, physical, and moral viewpoint, to standardize and encourage participation in athletics, to promote sportsmanship and an appreciation for and study of music, speech, and other fine arts through Region and State competitions.

## ARTICLE III — MEMBERSHIP

### SECTION 1 SCHOOLS ELIGIBLE FOR MEMBERSHIP

The membership of the Georgia High School Association shall consist of public and private high schools in the state of Georgia.

### SECTION 2 CLASSIFICATION OF SCHOOLS

- A. The Reclassification Committee of the GHSA Executive Committee shall place member schools in classifications and regions based on student F.T.E. figures and geographic proximity, respectively.
- B. Member schools will be realigned every two (2) years.
- C. The number of classifications and the number of regions will be determined by the Reclassification Committee at the time of each realignment.
- D. The number of classifications and regions, together with the assignment of schools therein, shall be submitted to the Executive Committee. The Executive Committee, by majority vote, may approve, reject or modify in any way the proposals submitted by the Reclassification Committee.

### SECTION 3 STRUCTURE OF REGIONS

- A. After reclassification, all regions will meet and submit to the State Office, after the final reclassification vote, a plan for structure of the regions. These plans must spell out subdivisions, if any, for all activities. All regions must have been approved before any scheduling may be finalized.
- B. In the event that any member school has a complaint with the structure of a region, it shall so advise the Executive Director and all other schools in the subject region of such complaint in writing within seven (7) calendar days after the region meeting following the final reclassification vote. The Executive Director shall then convene a meeting of the Reclassification Committee to review the present and proposed region structure and to attempt to arbitrate the differences and, failing that, to make a recommendation to the Executive Committee.

All schools in the subject region shall be advised of the meeting of the Reclassification Committee by the Executive Director and shall have the right to present evidence to the Committee. Any member of the Committee which is a member of the subject region shall be disqualified from participation on the Committee.

- C. The Executive Committee shall have full authority to require all or any portion of a subregion to play cross-over games and to align or realign the subject region into new subregions.

### SECTION 4 MEMBERSHIP IN ANOTHER ASSOCIATION

A school is not eligible for membership in the Georgia High School Association if it is or becomes a member of an association whose Constitution and/or By-Laws are in conflict with the Constitution and/or By-Laws of the Georgia High School Association.

**ARTICLE IV - GOVERNANCE****SECTION 1  
STATE OFFICERS**

The State Officers of this Association shall consist of a President, a Vice President, and an Executive Director.

**SECTION 2  
STATE EXECUTIVE COMMITTEE**

- A. Membership of the State Executive Committee shall be composed of the State Officers, the State Superintendent of Schools or his/her representative, and one member elected from each region in each classification, plus one member each appointed by the Georgia School Boards Association, the Georgia School Superintendents' Association, the Georgia Association of Secondary School Principals, the Georgia Athletic Directors Association, and the Executive Secretary of the Georgia Athletic Coaches Association. Membership shall also include two female members appointed by the Executive Committee upon recommendation of the Board of Trustees from nominees submitted by each region. Each member shall have the right to vote on all matters pertaining to the operation of the Association.
- B. Terms of office for members of the State Executive Committee elected by regions shall coincide with the length of each reclassification cycle.
- C. When a member of the State Executive Committee is unable to attend a State Executive Committee meeting, the President of the region shall have power to appoint an eligible member of the region concerned to represent the region at that meeting.
- D. The State Executive Committee shall have the authority to appoint smaller committees to address issues related to the operation of the Association and its regulated activities, and to consider proposals made by such committees. The authority of the State Executive Committee shall be plenary in all matters pertaining to the Association and it may accept, reject or modify any proposals made or action taken by any committee, the Board of Trustees, the Appeal Board, the Hardship Committee or the Executive Director.
- E. Each member of the State Executive Committee shall have the right to vote on all matters coming before the full State Executive Committee.

**SECTION 3  
BOARD OF TRUSTEES**

- A. Membership of the Board of Trustees shall be composed of the President, Vice President, and Executive Director, plus one member from each classification (as selected by a vote of the SEC representatives in that respective classification) and a total of four (4) at-large members (three (3) of which shall be appointed by the BOT) that must include at least two (2) females and two (2) private school representatives, and all four must be approved by a vote of the State Executive Committee. The term of office for members of the Executive Committee serving on the Board of Trustees shall coincide with the length of the reclassification cycle.
- B. The Board of Trustees shall receive and hold title to all real and personal property of said Association in trust for the benefit of said Association and shall have general custody and administration of such property with power and authority to lease, sell and convey said property of said Association; provided however, said Board of Trustees shall not sell or convey any real property so held by them in trust for said Association without first being authorized to do so by a majority vote of the State Executive Committee of said Association at a meeting duly called for such purpose.
- C. The Board of Trustees reviews pertinent issues relative to the successful operation of the organization. The Board of Trustees reviews the recommendation by the Executive Director concerning the budget, recommends committee appointments, evaluates and recommends length of contract for the Executive Director. The Board of Trustees recommends the two at-large female representatives to the Executive Committee.
- D. The Board of Trustees shall be authorized and empowered to exercise the powers of the Executive Committee including, but not limited to, the power to amend the by-laws of the association, and to otherwise make decisions relating to the association and its member schools as otherwise allowed to be made by the Executive Committee under the constitution and by-laws of the association.
  - 1. A majority of the Board of Trustees shall constitute a quorum thereof for the purposes of this Subsection D and action shall be authorized and taken by a majority of the votes cast.
  - 2. The meeting of the Board of Trustees under this section shall be noticed by the Executive Director or President by any reasonable means and any meeting of the Board of Trustees may be held electronically. In addition, such vote may be taken by telephone polling of the Board of Trustees by the Executive Director if appropriate in the discretion of the President.



3. Any action taken by the Board of Trustees under this Subsection D shall be subject to affirmation, rejection or modification at the next meeting of the GHSA Executive Committee or thereafter.
- E. Upon receiving a referral from the Executive Director of alleged intentional or grossly negligent violations of GHSA by-laws and rules by GHSA member schools or their personnel, the Board of Trustees by majority vote shall have the authority to assess further and additional penalties for such intentional or grossly negligent violations against the member school including, but not limited to, an additional fine of not more than \$2,500.00 for each such offense, and/or probation for a period of up to one calendar year in the sport(s) in which the violation occurred, and/or suspension of the member school from the GHSA for a period of up to one full calendar year. Any additional penalties assessed under this paragraph shall be appealable to the GHSA Executive Committee.

#### **SECTION 4 STATE APPEAL BOARD**

- A. The State Appeal Board shall be composed of members selected from the full State Executive Committee on a rotating basis.
- B. The duties of the State Appeal Board as set forth in Sec. 9 shall be performed by four (4) members of the Board sitting on an alternating basis as selected and notified by the Executive Director.
- C. Eligibility appeals in regard to the eight-semester rule will be referred by the Executive Director to the State Executive Committee for a final ruling.
- D. There shall be no appeal of eligibility related to age restrictions set forth in the by-laws.

#### **SECTION 5 HARDSHIP COMMITTEE**

- A.
  1. The Hardship Committee shall be composed of members selected from the full State Executive Committee on a rotating basis.
  2. The duties of the Hardship Committee shall be performed by four (4) members of the Executive Committee sitting on an alternating basis as selected and notified by the Executive Director.
- B. The Hardship Committee shall have the authority to set aside the effect of the migratory rule, the courses passed rule, and the accumulation of credits rule upon an individual student when in its opinion the rule works an undue hardship upon that student. The Hardship Committee does not hear cases regarding eight-semester violations, or appeals arising under the By-Laws.
  1. The Hardship Committee shall meet at a location and on dates established by the Executive Director and published in the GHSA Calendar. Requests will be considered to have a rule or rules set aside for benefit of individual students and shall consider such requests at the meetings held for that purpose, but not at any other meetings of the committee. If conditions upon which a request is based develop after April 1, the Executive Director is authorized to set a date for a special meeting to be held at the State Office to consider such case or cases.
  2. The principals of all member schools who have filed requests to have the effect of a rule set aside for individual students shall be notified of the time of the meeting at which such requests will be considered not less than seven (7) calendar days before such meeting.
  3. A request will be considered at a meeting only if complete information concerning the case is filed in writing with the Executive Director at least ten (10) calendar days prior to the date of the meeting and if a representative of the school, along with the student, is present at the meeting to furnish the Hardship Committee with information. Complete information includes a transcript.
  4. The conditions which cause the student to fail to meet the eligibility requirements must have been beyond the control of the school, the student, and/or his parents, and such that none of them could reasonably have been expected to comply with the rule. Ignorance of the rule on the part of any or all of them shall not be considered sufficient cause for setting aside its effects.
  5. The decision of the Hardship Committee shall be decided by a majority vote to set aside the effects of the rule in each individual case, and such decision shall not be considered as setting a precedent for other cases of a somewhat similar nature.
  6. The decision of the Hardship Committee shall be appealable to the Appeals Board by compliance with Sec. 9C & 9D of the Constitution and then to the State Executive Committee by compliance with Sec. 9F of the Constitution.

- C. 1. The Executive Director shall have the authority upon receiving an application by a member school to set aside the effect of any eligibility rule upon an individual student within the jurisdiction of the Hardship Committee and to grant the same without necessity of the appearance of the student or a representative of the school before the Hardship Committee when, in the judgement of the Executive Director, the circumstances regarding the application are such that:
- (a) The conditions which cause the student to fail to meet the eligibility requirements are beyond the control of the school, the student, and/or his parents and such that none of them could reasonably have been expected to comply with the rule; and,
  - (b) The conditions which cause the student to fail to meet the eligibility requirements work an unjust, unfair, and unforeseeable hardship upon the student; and
  - (c) The facts are clear, undisputed, and supported by appropriate documentation.
2. The Executive Director shall have the authority to grant or deny an application for hardship status.
- D. 1. The Executive Director shall have the discretion upon receiving an application by a member school to set aside the effect of any academic eligibility rule upon individual students when, in the judgement of the Executive Director, the following criteria are met:
- (a) The conditions which cause the student to fail to meet the eligibility requirements are beyond the control of the school, the student and his parents, and such that none of them could reasonably have been expected to comply with the rule; and
  - (b) The conditions which cause the student to fail to meet the eligibility requirements work an unjust, unfair and unforeseeable hardship upon the student; and
  - (c) The facts are clear, undisputed and supported by appropriate documentation and evidence; and
  - (d) The setting aside of the subject rule would not result in an unfair advantage to the school or student nor compromise the safety of any other student.
2. The decision of the Executive Director shall be appealable under the provisions of Section 9 of the GHSA Constitution and By-Laws.

## **SECTION 6 REGION OFFICERS**

- A. Each Region of each Classification shall elect a President, a Vice President, a Secretary-Treasurer, and from one to three committee members. No two of the above shall be from the same school unless the two are President and the Secretary-Treasurer. These officers, together with any member of the State Executive Committee from the region, shall compose the Executive Committee in their region.
- B. A member of the State Executive Committee who is not an elected member of his Region Executive Committee shall be an added member of his respective Region Executive Committee. This provision that only one (1) member of the Region Executive Committee may come from the same school will apply only to the members elected by the region, and will not apply when the State Executive Committee member in the region is from the same school as an elected member.
- C. The treasurer of each region is required to make an itemized statement of the income and expenditures of all funds to the region. When a new treasurer is elected, any balance must be turned over to the new officer immediately.

## **SECTION 7 DUTIES OF OFFICERS**

The duties of the various officers and committees shall be those usually devolving upon such officers and committees. It is specifically the duty of the State Executive Committee and the Region Executive Committees to seek at all times to educate the school officials under their jurisdiction, and at the same time, to check vigorously any practice or violation of the rules by exercising the full penalty for such violations if it is deemed necessary.

## **SECTION 8 ELECTION OF OFFICERS**

- A. A President and a Vice President shall be elected as State Association officers at the spring meeting of the Georgia High School Association for a term that shall coincide with the length of the reclassification cycle.
- B. The election and term of office of the Executive Director shall be for a term of one to five years at the discretion of the State Executive Committee and the President and Vice President of the Georgia High School Association and shall be authorized to execute a contract in the name of and for the Georgia High School Association.
- C. Only members of the State Executive Committee shall be entitled to vote in elections.

- D. Should the President become disqualified by death, resignation, or otherwise, the Vice President shall assume the office immediately and shall act as President until the vacancy is filled.
- E. Any vacancy which may occur in the office of President or Vice President shall be filled at the next meeting of the State Executive Committee.
- F. Each region in each Classification shall elect at any region meeting, a President, a Vice President, a Secretary-Treasurer, and from one to three region committee members as region officers.

Terms of office shall be for two (2) years, and elections shall be held at the beginning of each reclassification cycle. Any vacancy occurring on a Region Committee shall be filled by the Region Committee until the next meeting of the region.

- G. The State Executive Committee member from each region shall be elected at any Region meeting when there is a vacancy to be filled. The term of office shall coincide with the length of each reclassification cycle. Any vacancy occurring on the State Executive Committee shall be filled by the Region Committee until the next meeting of the region concerned.

**SECTION 9  
AUTHORITY OF EXECUTIVE DIRECTOR  
APPELLATE PROCEDURE**

- A. The State Executive Director shall be authorized to interpret the rules of the Georgia High School Association and to impose the proper penalty for their violation, including but not limited to, declaring a student ineligible to compete in GHSA activities for a period of time of up to four (4) years. The Assistant Executive Director shall, upon the absence or at the direction of the Executive Director, have all the powers and responsibilities of the Executive Director as provided under this Constitution and the By-Laws of the GHSA. The State Executive Director shall make all arrangements for holding and conducting the State Meets and Tournaments.
- B. All questions pertaining to eligibility or any other matters under the rules of the Georgia High School Association must first be submitted to the State Executive Director. If the question concerns a violation of any of the rules of the Georgia High School Association, the State Executive Director shall notify the member schools involved and advise them of the charges and advise them of their right to submit evidence and their right to request a hearing. The State Executive Director, after hearing or examining the evidence of the party or parties concerned, shall render a decision.
- C. Should any member school not be satisfied with the decision, appeal may then be made to the State Appeal Board by filing a written notice of appeal to the State Appeal Board through the State Executive Director within seven (7) calendar days of the date of the decision, which notice of appeal shall clearly state the decision appealed and the reasons for such appeal. The State Executive Director shall notify the State Appeal Board and all other parties of the appeal. Provided however, that if the only issue under appeal is to request modification of the penalty imposed by the Executive Director, then the member school may appeal directly to the Executive Committee. Any appeal of the decision of the Executive Director does not suspend the ruling made or penalty assessed pending a ruling on the appeal.
- D. Appeal Board meetings shall be set on dates established by the Executive Director and published in the GHSA Calendar.
1. Any request to the Appeal Board must be in the hands of the Executive Director seven (7) calendar days before the scheduled meeting date.
  2. Any other appeal requested (other than regularly scheduled dates) must be accompanied by a check sufficient to pay the entire estimated expenses of the Appeal Board to defray the cost of bringing the Appeal Board into session.
  3. All requests for appeals must be in writing with the stated reasons for an appeal, and signed by the administrative head of the individual school.
    - (a) An appeal of an eligibility decision must be based on one or more of the following reasons:
      - (1) There is substantial new information to be submitted that was not heard by the previous group making the decision that is being appealed.
      - (2) There is an allegation that a GHSA rule was misapplied in that ruling.
      - (3) There is an allegation that due process was not given in previous considerations.
    - (b) An appeal of a decision by the Executive Director must be based on one of the following reasons:
      - (1) There is an allegation that a GHSA rule was misinterpreted.
      - (2) There is an allegation that the Executive Director did not afford due process to the school.

- (c) All appeals shall set forth the basis for the appeal and the facts supporting the same, and shall be screened by the Executive Director for compliance with this rule prior to scheduling a hearing.
- E. The State Appeal Board, after hearing or examining the evidence submitted by the party or parties, may affirm or reverse the decision of the Executive Director. In order to sustain an appeal, the vote of the Appeal Board shall be unanimous.
- F. Should any member school not be satisfied with the decision of the State Appeal Board, they may appeal to the State Executive Committee by filing a written notice of appeal to the State Executive Committee through the State Executive Director within seven (7) calendar days of the date of the decision. The notice of appeal shall clearly state the decision being appealed and the reasons for such appeal. Such notice of appeal shall be accompanied by a check sufficient to pay the entire expenses of the State Executive Committee when such appeal is required to be heard at a time other than regularly scheduled meetings of the State Executive Committee.
- G. The State Executive Committee, after hearing or examining the evidence submitted by the party or parties concerned, shall render a decision to affirm, reverse, or modify the decision under appeal.
- H. No other method of appeal shall be held valid and any appeal must begin with the first step outlined and not eliminate any step until reaching the final court of appeal, the State Executive Committee. When the decision by the State Executive Committee is in favor of the appealing party or parties, the State Executive Committee may charge the expense of the meeting to the Georgia High School Association and reimburse the appealing party or parties.
- I. The Executive Director shall have the authority to lengthen or shorten the time for appeals of decisions, if required in his discretion, to accommodate pending schedules, events or other matters.
- J. Nothing in the Constitution of the GHSA is intended to give any individual students of GHSA member schools any due process or other rights as only member schools are entitled to any notice or opportunity to be heard in any questions coming before the GHSA. No student of GHSA member schools shall have any rights or benefits under this Constitution as a third party beneficiary or otherwise.

#### **SECTION 10 VOTE**

Each school shall have one (1) vote in a Region meeting and each member of the State Executive Committee shall have one (1) vote in the State Executive Committee meeting.

#### **SECTION 11 AMEND CONSTITUTION AND BY-LAWS**

- A. To amend the Constitution, it shall take a two-thirds vote of the members of the Executive Committee who are present at a regular or properly called meeting at which a quorum is present. Blank ballots, abstentions and pass votes are excluded.
- B. To amend the By-Laws, it shall take a majority vote of the members of the Executive Committee who are present at a regular or properly called meeting at which a quorum is present. Blank ballots, abstentions and pass votes are excluded.
- C. The effective date of any changes in the Constitution & By-Laws will be the next school year unless otherwise provided by the change.
- D. Proposed changes to the Constitution must be adopted at two separate meetings of the Executive Committee to be held not less than 30 calendar days apart.

#### **SECTION 12 BI-ANNUAL MEETINGS**

- A. The State Executive Committee of the Georgia High School Association shall meet in the spring and fall of each year on such dates as may be designated by the State Executive Director.
- B. In addition to these meetings, special meetings may be called by the State President or the Executive Director at any time or place upon giving reasonable notice to the members of the Committee.
- C. The Executive Director is required to present an itemized statement of the income and expenditures of all funds to the State Executive Committee.

**SECTION 13  
VIOLATION OF RULES**

- A. Each school is required to abide by all rules of the Georgia High School Association as promulgated by the State Executive Committee and interpreted by the Executive Director.
- B. The Executive Director is authorized to make such investigation as may be necessary and to judge whether or not a school has violated a rule. When a school is adjudged guilty, the Executive Director is authorized to direct the penalty or penalties, including but not limited to, declaring a student ineligible to compete in GHSA activities for a period of time of up to four (4) years. The Executive Director shall also have the authority to refer allegations of intentional or grossly negligent violations of GHSA by-laws and rules by GHSA member schools or their personnel to the GHSA Trustees for considerations of additional penalties.
- C. A school violating any rule, whether it be due to carelessness, willfulness, ignorance or any other cause, may be subject to a fine of not more than two thousand-five hundred dollars (\$2,500.00) for each offense, and/or probation in the sports(s) in which the violation has been made, and/or suspension from the Association up to a full calendar year, and/or forfeiture of games and/or contests involved. (NOTE: See Appendix "P" at the end of this publication for a detailed schedule of fines)
- D. PROBATION - placing a school on probation permits a school to compete in regular season games and/or contests, but bars that school from competing for any championship during the period of probation.
- E. A school which, after investigation, is adjudged guilty of violating the rules of the Georgia High School Association shall pay the costs incidental to such investigation; such cost to be in addition to fines or penalties assessed. Failure to pay the cost shall result in suspension or in lengthening the period of suspension.

**SECTION 14  
CODE OF ETHICS**

The Georgia High School Association recognizes its responsibility with respect to the promotion of honesty, truthfulness, and accuracy in record-keeping and reporting. Therefore, the professional personnel of the member schools are charged with upholding the Code of Ethics adopted by the Professional Standards Commission as accepted and approved by the State Board of Education.

**ARTICLE V — GENERAL PROVISIONS**

**SECTION 1  
CONTESTS**

- A. Each region may hold annual contests in literary, athletics, and other forms of contests designed to promote the cause of education and authorized by the State Executive Committee.
- B. Such contests must be held on dates to be announced in this Constitution and By-Laws under the rules governing State and Regional meets.
- C. Schools shall compete in their own classifications in State and Regional meets.
- D. Winners in regional meets may be sent to the State Meet in both athletic and literary events.

**SECTION 2  
ORGANIZATION PURPOSE**

- A. The purpose for which the Georgia High School Association is organized is exclusively educational within the meaning of IRC 501 (c) (3) or the corresponding provisions of any future United States Internal Revenue Law.
- B. Notwithstanding any other provisions of these articles, the Georgia High School Association shall not carry on any other activities not permitted to be carried on by an organization exempt from Federal income tax under IRC 501 (c) (3) or the corresponding provision of any future United States Internal Revenue Law.
- C. In the event of dissolution, the residual assets of the organization will be turned over to one or more organizations which themselves are exempt as organizations described in sections 501 (c) (3) and 170 (c) (2) of the Code or corresponding sections of any prior or future Internal Revenue Code, or to the Federal, State, or local government for exclusive public purpose.

## BY-LAWS

The Georgia High School Association recognizes that local boards and/or governing bodies may place more stringent requirements as they deem appropriate. The Association encourages all boards of education and/or governing bodies to extend the same rules and regulations to all extra-curricular activities under their jurisdiction.

These rules establish the provisions governing student eligibility to participate in interscholastic activities.

- A. The word “student” used in these By-Laws refers either to a boy or girl participant in interscholastic athletics, cheerleading, or literary activities. Therefore, according to correct grammatical usage, since the antecedent “student” can involve persons of both sexes, the masculine pronouns he, his, or him used throughout said By-Laws will refer to either male or female participants.
- B. The word “principal” used in these By-Laws refers either to a male or female head of a secondary school. Therefore, according to correct grammatical usage, since the antecedent “principal” can involve or refer to persons of either or both sexes the masculine pronouns, he, him, or his, will refer to a male or female head of a secondary school.
- C. The abbreviations GHSA used throughout these By-Laws refers to the Georgia High School Association.
- D. Nothing in the By-Laws of the GHSA is intended to give any individual students of GHSA member schools any due process or other rights as only member schools are entitled to any notice or opportunity to be heard in any questions coming before the GHSA. No student of GHSA member schools shall have any rights or benefits under these By-Laws as a third party beneficiary or otherwise.

### BY-LAW 1.00 - STUDENT

#### 1.10 - CERTIFICATION OF ELIGIBILITY

- 1.11 **Students gain eligibility** to practice or compete for the school in which they are enrolled after they have been certified by the principal of that school, after the eligibility forms have been processed by the GHSA office, and after the students have met the standards of:
  - (a) academic requirements
  - (b) age
  - (c) semesters in high school
  - (d) residence in the school's service area
  - (e) transfer rulesNote: Students establishing eligibility as entering 9th graders are automatically eligible for the first semester unless over age.
- 1.12 The **certification of eligibility** shall be submitted initially in each sport or activity no later than the date set by the GHSA for the first practice in that sport or activity.
  - (a) This due date does not consider the date of the first contest scheduled.
  - (b) EXCEPTION: Literary, One-Act Play and Riflery certification is due twenty (20) calendar days prior to the first scheduled contest.
- 1.13 If a student ruled ineligible by the GHSA, competes interscholastically due to the terms of a **court restraining order or injunction** against his/her school and/or the GHSA, and then has the court order vacated, stayed, reversed, or ruled unjustified; the Executive Director shall take one or more of the following actions against the school involved in the interest of restitution and fairness to the competing school(s):
  - (a) Require that individual and/or team records and performances achieved during participation by the ineligible student be vacated or stricken.
  - (b) Require that team victories be forfeited to the opponent(s).
  - (c) Require that team awards earned by the school or individual awards earned by the ineligible student be returned to the GHSA.

#### 1.20 - ENROLLMENT AND TEAM MEMBERSHIP

- 1.21 **To be eligible to participate and/or try-out** for a sport or activity, a student must be enrolled full time in grades 9-12 inclusive at the school seeking eligibility for that student.
  - (a) Enrollment is defined as follows:
    - (1) Fall Semester: when the student participates in a practice or contest before classes begin, or the student attends classes.
    - (2) Spring Semester: when the student attends classes.
    - (3) A student may be enrolled in only one (1) high school at a time.
  - (b) The student must be in regular attendance.

- (c) The student must be taking courses that total at least 2.5 Units that count toward graduation.  
NOTE: If an eligible student transfers from a school on a block-schedule format to a school using a traditional format (or vice versa) and cannot get a full schedule of classes with equivalent credit, the school may petition the Executive Director for a waiver of this rule for the semester the transfer occurs.
- (d) All or part of the course load of a student may be taken online through a virtual school as long as the student's grades are being kept at the school in which the student is enrolled. Grades from virtual school courses must be on file at the school by the first day of the new semester for the student to be eligible.

1.22 Students enrolled in **grade 9 in a middle or junior high school** which is a feeder school to the high school may participate in interscholastic activities for the parent school.

1.23 All-male schools may enlist female students from other schools to be on sideline cheerleading squads as long as the following conditions are met:

- (a) Each cheerleader must be eligible at the school at which she is enrolled, and must have a signed release from an administrator at that school.
- (b) Each cheerleader must have a GHSA Pre-participation Physical Evaluation Form on file at the school where she will be cheering as well as at the school at which she is enrolled.
- (c) Each cheerleader must have insurance coverage comparable to all other participants in GHSA activities.
- (d) Supervision must be provided by the all-male school for all practices and games.

### 1.30 - AGE

To be eligible to participate in interscholastic activities, a student must not have reached his 19th birthday prior to May 1st, preceding his year of participation.

### 1.40 - LIMITS OF PARTICIPATION

1.41 Students must have a certificate of an **annual physical examination on file** at the school prior to participating in any athletic try-outs, practices, voluntary workouts or games that indicate the students are physically approved for participation.

- (a) Physical examinations will be good for twelve (12) months from the date of the exam. EXCEPTION: Any physical examination taken on or after April 1 in the preceding year will be accepted until that school ends classes the next Spring or concludes its final Spring sports season (for those participating students).
- (b) The physical exam must be conducted by a licensed medical physician, doctor of Osteopathic medicine, nurse practitioner or a physician's assistant.
- (c) The exam must be signed by an M.D., D.O., or by a Physician's Assistant, or an Advance Practice Nurse who has been delegated that task by an M.D., or D.O.
- (d) The GHSA requires that member schools use the edition of the preparticipation physical evaluation form approved by the American Academy of Pediatrics, et. al., found on the GHSA web site.

1.42 A student has **eight (8) consecutive semesters** or four (4) consecutive years of eligibility from the date of entry into the ninth grade to be eligible for interscholastic competition.

- (a) A student is not considered to have entered the 9th grade when high school level courses are taken if the student is regularly enrolled in a school in a grade below the ninth grade.
- (b) Credits earned toward high school graduation which are taken below the ninth grade may be used when considering high school eligibility.
- (c) The provisions of the eight-semester rule in the case of an individual may be waived by the Executive Director upon presentation of evidence of true hardship beyond the student's control, or by the State Executive Committee upon timely application by a member school for placement on the agenda.

1.43 **Sub-varsity competitors** must meet all eligibility requirements with the exception of the migratory rule.

1.44 Students in grade 9 and higher may participate on **both the varsity and one (1) sub-varsity team** in the same sport with the following limitations:

- (a) Football – a player may not participate in interscholastic competitions more than six (6) quarters per week, beginning with the varsity game.
- (b) Basketball – a player may not participate in interscholastic competition more than six (6) quarters per calendar day. (Note: Tournaments are exempt from this restriction.)
- (c) Soccer – a player may not participate in interscholastic competition more than three (3) halves per calendar day. (Note: Tournaments are exempt from this restriction.)
- (d) Lacrosse – a player may not participate in interscholastic competitions more than six (6) quarters per day.
- (e) Wrestling – the combination of play dates (wrestling and girls wrestling) in which a student participates may not be greater than the current varsity limit of play dates.
- (f) All other sports - the combination of games or play days (varsity and sub-varsity) in which the student participates may not be greater than the limit allotted to the varsity in that sport (NOTE: Exceptions may be made by the Executive Director.)

**NOTE:** Violations of these participation rules in ANY sport will result in a mandatory fine and an automatic forfeiture of the game in which the student exceeded the limit. Additional penalties may be imposed by the Executive Director in extreme circumstances.

- 1.45 **Eighth grade students** may participate on a sub-varsity team of a high school provided they attend a feeder school of that high school.
- Students in grade 8 are never eligible for a varsity event in any activity.
  - Eighth grade students who play on a high school team must meet all middle school requirements as put forth by the State Department of Education.
  - An eighth grade student who is declared ineligible at a middle school or retained for academic reasons, is considered to be ineligible for participation on a sub-varsity high school team.
  - Eighth grade students participating on a sub-varsity team may only participate in 70% of the number of games allotted to the varsity team in that sport. Eighth grade students may not participate in more sub-varsity and middle school contests combined than the number the GHSA allows for varsity competition in that respective sport.
  - Students below the eighth grade are not eligible to participate on any high school team.
  - Students enrolled in grade 8 in a middle school or junior high school which is a feeder school to the member high school may participate in Spring football practice.
  - Students enrolled in grade 8 in a middle school or junior high school which is a feeder school to the member high school may **try out** for cheerleader at the high school. Eighth grade students at a non-feeder school that has no system high school may participate in cheerleader tryouts at the member high school serving the student's area of residence. Such a student must be pre-enrolled at that member high school, and once pre-enrolled, the student has established eligibility at that high school.
  - Eighth grade students who attend a feeder school for one member high school may NOT participate in any sport or activity practice at a different member high school.
  - All eighth grade students should be reported on Eligibility Form D, available on the GHSA web site.
- 1.46 The number of contests, start and end dates, and the number of practice days allowed for each sport or activity can be found listed in a calendar at the front of this publication. (NOTE: The season ends for a team when that team is eliminated from the post-season competition or wins the State Championship in that sport.)
- 1.47 **A student's gender** is determined as follows:
- Girls may participate on boys' teams when there is no girls' team offered in that sport or activity by the school (**exception:** wrestling). Boys may not participate on girls' teams even when there is no corresponding boys' sport or activity. Cheerleading is a coed sport.
  - A student's sex is determined by the sex noted on his/her certificate at birth.
  - The GHSA will attempt to accommodate requests for private restroom or locker/dressing room facilities for students requesting the same at GHSA playoff events or contests provided notice of the request is made as soon as possible to the GHSA office. No student shall be required to utilize the private facilities.
- 1.48 **Advisory Notice - Pregnant Students:** In response to the increasing number of pregnant students attending member schools, and the continued participation of these students in GHSA activities, the following advisory notice is being offered:
- During the first 18 weeks of pregnancy, students, with written consent from a physician, may be allowed to participate in athletic activities except those activities in which a fall or other rapid deceleration is likely to occur.
  - Pregnant students are not allowed to participate in any athletic activities after the 18th week of pregnancy.
- 1.49 Schools having students participate in athletic activities with **artificial limbs** must certify that the artificial limb is no more dangerous to participants than a natural limb.
- A permission form must be filed with the GHSA office.
  - The form may be found in the Miscellaneous section on the GHSA web site.

## 1.50 - SCHOLASTIC STANDING / SCHOLARSHIP

- 1.51 To be eligible to participate, practice, and/or try out in interscholastic activities, a student must be academically eligible. A student is required to pass classes that carry at least 2.5 Units counting toward graduation the semester immediately preceding participation. Exception: First semester ninth-grade students.
- Passing in all GHSA member schools is a grade of seventy (70).
  - Students participating in junior varsity or "B" team competition must meet all scholastic requirements.
  - If an eligible student transfers from a school that uses a block-schedule format to a school using a traditional format (or vice versa) and that student cannot get a full schedule of classes with equivalent credit in the semester of the transfer, the school may petition the Executive Director for a waiver of this rule for the first semester after the transfer occurs.
  - For schools offering courses with yearlong grading, eligibility must be computed for each semester.



- (1) At the end of the first semester, the school must determine that the student has a grade of 70% or higher in classes carrying at least 2.5 Units.
  - (2) The second semester grade will be the grade given for the entire course and shall include the end-of-course test grade.
  - (3) Remediation programs designed to bring the student's first semester grade up to 70% or higher may be used (in accordance with GHSA guidelines) if the school allows such programs for all students.
- 1.52 Students gain or lose eligibility on the first day of the subsequent semester. The first day of the Fall semester shall be interpreted as the first date of practice for the first sport.
- (a) Exception: Students who successfully complete summer school to maintain eligibility become eligible the last day of summer school.
    - (1) Summer school is an extension of the previous semester and courses may be:
      - a. remedial in nature where a previously-taken course is repeated in its entirety with a new grade being given.
      - b. enrichment in nature where a new course is taken that results in new credit being earned.
    - (2) A maximum of two (2) unit credits earned in summer school may be counted for eligibility purposes. NOTE: Additional credits may be earned in credit recovery programs or make-up programs after the start of the new semester.
    - (3) Summer school credits earned in non-accredited home study programs or non-accredited private schools may not be used to gain eligibility. Accreditation recognized under the rule shall be from the Georgia Accrediting Commission (GAC) or a regional accreditation agency (such as SACS) or the Georgia Private School Accreditation Council (GAPSAC).
    - (4) An independent study course taken in summer school must be regionally accredited and accepted by the school system for graduation credit.
  - (b) Courses completed after the beginning of a new semester may not be used to gain eligibility for that semester. Example: night school classes, correspondence courses, etc.
  - (c) Independent study courses taken during the school year must meet the criteria of 1.52 (a) 4.
- 1.53 Students must **accumulate units towards** graduation according to the following criteria:
- (a) **First-year students** (entering 9th grade) are eligible academically. Second semester **first-year students** must have **passed courses carrying at least 2.5 units** the previous semester in order to participate.
  - (b) **Second-year students** must have **accumulated five (5) total units** in the first year, **AND passed courses carrying at least 2.5 units** in the previous semester.
  - (c) **Third-year students** must have **accumulated eleven (11) units** in the first and second years, **AND passed courses carrying at least 2.5 units** in the previous semester.
  - (d) **Fourth-year students** must have **accumulated seventeen (17) units** in the first three years, **AND passed courses carrying at least 2.5 units** in the previous semester.
  - (e) Students may accumulate the required units for participation during the school year and eligibility will be reinstated at the beginning of the next semester.

---

#### ADVISORY NOTICE: CURRICULAR INNOVATIONS

##### A. BLOCK FOUR PROGRAMS:

1. The student takes four courses that are worth one (1) unit each and the classes meet twice the number of hours per week as in the standard curricular programs.
2. To be eligible, a student must earn at least 2.5 units.
3. Unit requirements are the same in all curricular programs.

##### B. BLOCK EIGHT PROGRAMS:

1. The student takes eight courses at some time during the term, and each course is worth one-half unit.
2. To be eligible, a student must earn at least 2.5 units during the term.
3. Unit requirements are the same in all curricular programs.

##### C. HYBRID SCHEDULING:

1. Definition: A student takes a combination of courses scheduled as block courses, yearlong courses and/or traditional courses.
2. To be eligible, a student must be enrolled in a combination of courses that carry at least 2.5 units.
3. To be eligible, a student must have passed a combination of courses the previous semester that carries at least 2.5 units.

- 
- 1.54 A Dual Enrollment program is defined as a program in which a fulltime student at a GHSA member high school takes one or more courses from a state public or private postsecondary institution and receives credit at the high school (toward graduation) and at the postsecondary institution.

- (a) Dual enrolled students shall take courses that are approved by the Georgia Department of Education.
  - (b) Courses may be taken in a variety of formats (including distance learning and virtual courses) as long as the courses are approved.
  - (c) Postsecondary semester hour credit shall be converted to high school unit credit as follows:
    - (1) 1-2 semester hours equates to .5 unit
    - (2) 3-5 semester hours equates to 1 unit
  - (d) Postsecondary quarter hour credit shall be converted to high school unit credit as follows:
    - (1) 1-3 quarter hours equates to .5 unit
    - (2) 4-8 quarter hours equates to 1 unit
- 1.55 Students involved in approved Dual Enrollment programs shall be eligible to participate in GHSA activities provided that academic eligibility is maintained.
- (a) Courses taken each semester at the high school and/or postsecondary institution must total at least 2.5 units.
  - (b) Courses passed the previous semester at the high school and/or postsecondary institution must total at least 2.5 units
  - (c) Students will gain or lose eligibility on the first day of each semester at the high school and a college calendar that differs from the high school calendar may cause problems.
  - (d) Students who withdraw or are dropped from a Dual Enrollment program and are returned to the high school only, may encounter eligibility problems.
  - (e) Students involved in Joint Enrollment programs, Early College programs, or Gateway to College programs may not be eligible at their respective high schools.
  - (f) A student who participates on an intercollegiate athletic team may not participate in any GHSA activity.
- 1.56 **Loss of Eligibility:** Students assigned to an **alternative school** or on **out-of-school suspension for disciplinary reasons, or adjudicated to YDC**, lose their eligibility. Suspension is considered to have ended when the student is physically readmitted to the classroom.
- 1.57 **Failure to Meet Academic Standards:** When a school administrator believes that the student has failed to meet the academic eligibility requirements due to conditions that were beyond the control of the school, the student, and/or his parents, and such that none of them could have been expected reasonably to comply with the rule, he may request that the student's case be put on the agenda of the **Hardship Committee**.
- (a) Ignorance of the rule(s) on the part of any individual is not sufficient cause to set aside the rule(s).
  - (b) Schools must supply all the materials requested on the Hardship Application Form on the GHSA website.
- 1.58 **Credit Recovery/Make-up Work:** Students who have academic deficiencies at the end of a semester may make up those deficiencies in programs that are available to any student in the school. NOTE: Programs allowing students to recover academic credit have a variety of names in various schools.
- (a) Credit recovery programs are short-term programs that involve a course that has been completed and a grade given. The student is given the opportunity to work on areas of deficiency.
  - (b) Make-up programs occur when a course has not been completed and an "Incomplete" grade has been given. The student is given the opportunity to work on areas of deficiency.
  - (c) Credit recovery and make-up work must be completed by the first day of the first semester and within 15 school days after the beginning of the second semester. The student is ineligible until such time as the work is completed and the required passing grade has been recorded. Exception: If the end-of-course test is not offered before the first day of the first semester or within the 15-school-day window of the second semester, the student may be granted a reasonable extension by the GHSA.
  - (d) The GHSA Executive Director shall be authorized to approve credit recovery or make-up work completed later than the first day of the first semester or subsequent to the 15-school-day window of the second semester if he finds that the:
    - (1) timeframe was not met due to circumstances outside the control of the student, his parent(s), and the school, AND
    - (2) work was completed as soon as reasonably possible, AND
    - (3) allowance for such a delay is offered on the same basis to all students in the school.
  - (e) Credit recovery programs operated during the summer shall be completed by the first day of the first semester. Students using those credits to gain eligibility are ineligible until the course is completed successfully. Credit recovery is used for remedial work only, and no new credit courses may be applied under this provision.
  - (f) Students using credit recovery or make-up programs must have their eligibility submitted to the GHSA office on a "Form C."
- 1.59 **Students with disabilities:**
- (a) A student with disabilities who is enrolled in a special education program which is not physically located at the parent school (example: psycho-education center, regional occupation center, community-based

instruction class, etc.) shall be eligible to participate, practice, and/or try out in interscholastic activities at the parent school if IEP (Individual Education Program) requirements are met.

- (b) Schools with students having to meet only IEP requirements for course credit must establish an accounting process for the number of courses passed each semester, and for the awarding of units. Requirements for the date of entry into the ninth grade and for age apply to students with IEPs without variation.
- (c) Competitive interscholastic activities administered through local **special education programs** shall follow Georgia Department of Education guidelines and procedures for special education, and are exempt from GHSA requirements.

## 1.60 - SCHOOL SERVICE AREAS / TRANSFER / MIGRANT STUDENTS / MIGRATORY WAIVER

1.61 School **service areas** for member public schools are those attendance boundaries established by local boards of education from which a school normally draws its students. The service area for a member private school is the public school's attendance zone in which the private school resides. The service area for a startup or converted charter school will be the same as the school from which the charter school draws its students.

1.62 A **transfer student** who has established eligibility at a former school in grades 9-12 shall be **immediately eligible** at the new school **if**:

- (a) The student moved simultaneously with the entire parental unit *and all other persons he/she lived with at the former residence, and that residential unit moved into the service area of the new school with simultaneous enrollment of the student in the new school.* This is known as a "**bona fide move.**" (NOTE: A move within the **same** service area does not constitute a bona fide move.)
  - (1) The student may choose the public or private school serving that area.
  - (2) It must be apparent that the parent(s) *and all the persons residing with the student and the student have relinquished the residence in the former service area and have occupied a residence in the new service area.*
  - (3) The following factors, although not conclusive, may be evidence of relinquishment of the former residence: Selling the residence and vacating it; OR vacating the residence and listing it for sale at a fair market value; OR vacating the residence and leasing it to another (other than a relative) at fair market value; OR abandoning the residence and shutting off the unnecessary utilities. NOTE: When a family claims multiple residences, the residence for which they apply for a homestead exemption will be declared the primary residence provided the family spends the majority of their time at this residence.
  - (4) The bona fide move is validated when the student's family maintains the new residence for at least one calendar year. A return to the previous service area within that year renders the student to be a migrant student. All hardship appeal processes are available.
- (b) The student was enrolled in a **private school or a magnet school** and has a bona fide move from one public school service area to another public school service area. A student in this situation may attend either the public school or a private school serving his area of residence.
- (c) The student was enrolled in a **non-member school** in Georgia and, without a bona fide move, transferred to a GHSA member school that serves his area of residence as long as:
  - (1) It is the initial move of the student from a non-member school to a member school serving his area of residence, AND
  - (2) The student was enrolled at the high school serving his area of residence in grades 9-12 before attending the non-member school, OR
  - (3) The student has not yet established eligibility in grades 9-12 at a member school serving his area of residence.
  - (4) A student who transfers from a GHSA member school to an independent school entering the GHSA in the next school year must be enrolled at the entering independent school by January 31 of the year preceding their becoming a GHSA member school in order to be eligible.  
NOTE: Rules about joint custody transfers have control over the one-time transfer restriction in this by-law.
  - (5) In compliance with the Dexter Mosley Act, schools must file eligibility for **home study students** using Transfer Eligibility Form "HS" found on the GHSA web site.
- (d) The student transfers from a non-member home school and the receiving school grants credit so that the student has accumulated sufficient units. At the time such credit is given, the student must also have passed a minimum of at least 2.5 units the previous semester. The student becomes eligible when credit is awarded officially.
- (e) The student is involved in a **foreign exchange program** that is approved and published on the "Advisory List of International Educational Travel and Exchange Programs" published by the Council on Standards for International Educational Travel (CSIET). This list is found on the GHSA web site.
  - (1) The student shall be considered eligible for a maximum period of one calendar year.
  - (2) The student shall not be a graduate of a secondary school in his home country.
  - (3) The student must maintain eligibility requirements at the member school.

- (4) The foreign exchange program must randomly assign students to schools by a method that insures that no student, school, or other interested party may influence the assignment for athletic purposes. “Direct Placement” foreign exchange students must go through the hardship appeal process to become eligible.
- (5) All eligibility forms (Form B) for foreign exchange students must be accompanied by documentation from the CSJET-approved foreign exchange program showing that the student has been placed according to the normal procedures for that agency.
- (f) If one of his/her parents or the custodial parent is a certified teacher or administrator teaching in grades 9-12 at the receiving school. This opportunity is available one time only at any given school. (NOTE: Rules about joint custody transfers overrule the one-time transfer restriction in this by-law.)
- (g) The student has one of the following family related circumstances which shall constitute a waiver of the “bona fide move” rule:
- (1) There is a **Superior Court Final Order** changing permanent physical custody of the student from one parent to the other parent and the student moves to the residence of the parent receiving custody in a new service area and attends the member school serving that service area. Note: All cases involving non-parental custody changes must be appealed through the hardship process.
  - (2) There is a **Superior Court Final Order** awarding permanent joint physical custody to the parents and the student elects to move from the residence of one parent to the residence of the other parent in a new service area and attends the member school serving that area of residence. Provided, however, that such an election can be made only once during a 12-month period beginning the date of the transfer and the Final Order must have specifically awarded the parents “joint physical custody” of the student. Award of “joint legal custody” shall not suffice for purposes of this paragraph.
  - (3) There is a death of the custodial parent with whom the student resided and the student moves to live with the other parent in a new service area and attends the member school serving that area of residence.
  - (4) There is a military transfer of one or both custodial parents that requires a change of residence of the student to a new service area and the student attends the member school serving that area of residence.
- (NOTE: Eligibility forms for transfer eligibility under paragraphs (1), (2) and (3) above must be accompanied by certified copies of applicable Court Orders. Eligibility forms for transfer eligibility under paragraph (4) above must be accompanied by true and correct copies of verifiable deployment orders.)
- (h) Students who are U.S. citizens and who have been enrolled and attended a high school in a foreign country, upon return to the U.S., shall be eligible to participate at a GHSA member school provided the student lives in the new school’s service area and is otherwise eligible under GHSA age, eight-semester, academic and other eligibility rules.
- (i) Students who are transferred from one school attendance area to another school attendance area by a **mandate of the local board of education** maintain their eligibility.
- (j) **Married students** setting up a household (domicile) shall be eligible in the school of their residence provided they meet all other requirements of eligibility.
- (k) Students at the Atlanta School for the Deaf will be eligible at the school serving their area of residence provided they meet all other eligibility requirements.
- (l) The migratory rule (See 1.63) will be waived **one time for boarding students only who enter the following schools:** Ben Franklin Academy; Darlington; Tallulah Falls.  
Exception: Students from foreign countries not on an approved foreign exchange program are not eligible.
- (m) Students entering a school as an “unaccompanied youth” under the conditions of the McKinney-Vento Act must go through the hardship appeal process to become eligible.
- (n) If approved by the local board of education, students enrolled in a **magnet or specialty school established by the local board of education** shall be allowed to participate in GHSA extracurricular activities as a member of the school team for the school which they would ordinarily attend according to local board of education attendance policy. Provided, however, that:
- (1) If the magnet/specialty school offers the only activity in which the student elects to participate, the student shall be required to participate as a member of the magnet/specialty school program in that activity.
  - (2) Students at magnet/specialty schools may not participate in GHSA extracurricular activities at both the magnet/specialty school and the school that the student would ordinarily attend. Those students must elect to participate in GHSA extracurricular activities at only one school per school year. For example, students could not play basketball at the magnet school and football at the home school.
  - (3) The election of the student to participate in GHSA extracurricular activities for either the magnet/specialty school or the school the student would ordinarily attend shall be binding for the current school year.
  - (4) Such students shall be required to comply with all GHSA eligibility and other rules. The member school shall be required to provide to the GHSA a copy of the local board of education approval of such participation.
  - (5) The receiving school will submit students on an MT Eligibility Form. This form is available on the GHSA web site ([www.ghsa.net](http://www.ghsa.net)).

**1.63 Student Eligibility**

- (a) A “**migrant student**” is a student who transfers into a GHSA school without a bona fide move or without one of the exceptions listed in by-law 1.62. The student may practice or compete at the sub-varsity level, but may not compete at the varsity level for one calendar year from the date of entry into the new school. In the event that, after transfer, a student becomes or is later determined to be a migrant student, then the student shall be ineligible to compete at the varsity level for one calendar year from that date.
- (b) If a student has been ruled eligible to participate by the GHSA, but it is later determined that such eligibility should not have been approved, any ineligibility to participate in future GHSA activities may be assessed as of the date that such ineligibility was determined.

1.64 A student who is not eligible at the former school, and then transfers to a new school, cannot regain eligibility by the transfer. Academically ineligible students cannot gain eligibility by being adjudicated to YDC and subsequently returning to their resident school with earned credit. NOTE: The new school may file a hardship appeal if circumstances warrant.

1.65 Students whose transfers from member school to member school have been approved by the GHSA office after the end of regular season play or during post-season play are not eligible for participation in GHSA sponsored tournaments and/or playoffs in that particular sport for the school year of transfer.

1.66 A student who is not eligible at one school because of **suspension or expulsion** and then transfers to a member school cannot regain eligibility by such a transfer, for the length of the suspension or one calendar year, whichever is less.

1.67 A **permissive transfer** is defined as an allowance by a local board of education for students and/or their parents to choose a school to attend without regard to the location of residence.

- (a) A student transferring from member school to member school on a permissive transfer is considered a migrant student.
- (b) A student transferring to or from a school housing a system-wide, singular academic or vocation program or a magnet program on a permissive transfer is considered a migrant student.
  - (1) The offering of an individual course or series of courses by one school in a system does not provide inherent justification to grant GHSA eligibility.
  - (2) Special options offered by a school system that allow students to attend a school outside their area of residence do not provide inherent justification to grant GHSA eligibility.
  - (3) Any such permissive transfer issue may be brought before the GHSA Hardship Committee.
- (c) Students transferring under the provisions of Federal or State academic accountability regulations must be processed through the normal hardship appeals process.
- (d) When a military base is located in two school districts, a student moving onto the base for the first time may choose to attend either school district, and that district will place the student appropriately. Any transfer after the initial placement will be subject to standard eligibility regulations.

1.68 **Hardship Applications** may be filed by an administrator at a member school when a student does not meet the standards of eligibility outlined in by-laws 1.50 (academic issues) and 1.60 (transfer issues).

- (a) The GHSA Constitution (Art. IV; Sec. 5; Subsection B4) specifies that the hardship issues must be beyond the reasonable control of the persons involved.
- (b) The process of appealing a decision of the Hardship Committee is outlined in the GHSA Constitution (Art. IV, Sec. 9, Subsection C & D).
- (c) In order for a hardship appeal based on a financial hardship to be approved, the new school must provide proof that the family attempted to address the financial problem at the previous school, and that the need-based financial aid was non-existent or insufficient to resolve the problem. Increases in tuition or other costs at a private school do not create an automatic reason to grant the appeal, because such fee increases are considered foreseeable and not unavoidable. Documentation of the financial problem is required.

1.69 When a new school opens, student eligibility shall be determined as follows:

- (a) When a school district mandates a service area for a new school for all grades enrolled at the new school, all students living within the mandated service area in those grades are immediately eligible. All students living outside the mandated service area who desire to attend the new school are considered migrant students and are ineligible for one year. Hardship appeals may be filed if conditions warrant.
- (b) When a school district mandates some students to attend the new school, allows some students to stay at their present school, and permits some students to transfer to the new school, the school shall set a deadline for students living in the service area of the new school to decide whether they will move to the new school, or stay at the present school. The decisions exercised at the deadline date are binding. Subsequent changes render the student to be a migrant student with the one-year period of ineligibility. Students who are granted permissive transfers to enroll at the new school from other schools within the system are considered to be migrant students. Hardship appeals may be filed if conditions warrant.

**1.70 - RECRUITING/UNDUE INFLUENCE / FOLLOWING THE COACH**

- 1.71 **Recruiting and Undue Influence** is **defined** as the use of influence by any person connected directly or indirectly with a GHSA school to induce a student of any age **to transfer** from one school to another, or **to enter** the ninth grade at a member school for athletic or literary competition purposes, whether or not the school presently attended by the student is a member of the GHSA.
- (a) The use of undue influence to secure OR retain a student for competitive purposes is prohibited, and shall lead to penalties being assessed against **either school**. This violation may cause the student to forfeit eligibility for one year from the date of enrollment, provided however, that such period of ineligibility may be assessed from the date that recruitment/undue influence violation was finally determined to have occurred with regard to the student rather than from the date of enrollment.
  - (b) Evidence of undue influence includes, but is not limited to:
    - (1) personal contact with coaches, boosters, or other school personnel discussing participating in athletics upon a proposed transfer
    - (2) gifts of money, jobs, supplies, clothing, or housing incentives
    - (3) free transportation
    - (4) free admission to contests
    - (5) an invitation to attend practices and/or games
    - (6) a social event (other than an official schoolwide Open House program) specifically geared for prospective athletes
    - (7) free tuition beyond the allowable standards found in by-law 1.82
    - (8) a coach asking a prospective student for contact information
  - (c) Complaints or reports of violations of this rule will be investigated and handled on a case-by-case basis. If **coaches** are found to be in violation of the recruiting rule, a copy of the investigation will be forwarded to the Professional Standards Commission of the Department of Education.
  - (d) A school will be afforded an opportunity to demonstrate it could not reasonably be expected to be responsible for the actions of a booster who is found to have violated the recruiting/undue influence rules.
- 1.72 **Following The Coach:** A student athlete transferring from one school to another, *or entering the ninth grade for the first time*, shall be ruled ineligible for one year if it is proven that:
- (a) The coach of the receiving school coached an out-of-school team or all-star team on which the athlete played prior to the transfer; OR
  - (b) The coach at the receiving school acted as a private athletic instructor for the transferring athlete, regardless of whether the coach was paid for his services and/or expertise; OR
  - (c) The student participated in a sports camp or clinic run by a member school and/or its coach(es).
  - (d) The player who played for a coach at one school (GHSA member or non-member) and subsequently (within a 12-month period) followed that coach when he/she moved to a GHSA school or changed schools within the GHSA membership. (This is not applicable to dependent children of the coach.)
  - (e) The situations cited in this by-law are considered to be violations even if a bona fide move has occurred. Hardship appeal procedures are available for the demonstration that undue influence has not occurred.
- 1.73 A booster shall be considered to be an extension of the school and must abide by all rules applied to coaches and other school personnel. The following persons or groups may be considered boosters: members of the school's Booster Club; students; alumni; parents; guardians; or relatives of a student or former student; financial donors; donors of time and effort; personal trainers or coaches renting facilities.

**1.80 - FINANCIAL AID**

- 1.81 Any student who receives financial aid or non-GHSA approved gifts from any source and in any form (scholarships, tuition remission, cash, gifts, etc.) arising out of or **received in connection with their participation** in any sport or literary event shall be ruled ineligible. The duration of the ineligibility will last as long as the illegal benefits are being received. This prohibition shall not apply to awards under By-Law 1.90 or to other items approved by the GHSA.
- (a) If tuition is charged, it must be paid by a parent, legal guardian, or other family member with the exception of payments coming from need-based financial aid.
  - (b) It is not legal for donated funds to be designated for a specific student that are given by non-family members, businesses, churches or other organizations, except for programs specified by state law.
  - (c) Schools may not employ students to work off their tuition costs.
  - (d) The GHSA Executive Director will determine whether the financial aid or gift arose out of or in connection with participation in any sport or literary event.
  - (e) If a school allows a student who has received such financial aid or gifts to participate in competition, the Executive Director shall assess an appropriate penalty.
- 1.82 Financial aid in the form of free or reduced tuition or other aid must be **need-based aid** as determined by a national student aid service or financial aid based on institutional policies for academic performance (classroom record and/or test scores) that is administered by persons not in the athletic department.

- 1.83 Member schools who award financial aid shall issue a statement to the Executive Director signed by the principal or headmaster of the school giving the following information:
- number of students enrolled in the school
  - number of students receiving financial aid
  - names of students (or a listing of student identification numbers) receiving financial aid who are involved in GHSA activities
  - certification that the percentage of students who participate in activities and who receive financial aid is the same percentage as the number of students receiving financial aid who do not participate in activities (plus or minus 5%)

## 1.90 - AMATEUR STATUS/AWARDS

- 1.91 A student who represents a school in interscholastic athletic competition shall be an **amateur** in that activity.
- An **amateur athlete** is one who engages in athletic competition solely for the physical, mental, social, and pleasure benefits derived therefrom.
  - Accepting nominal, standard fees or salary for instructing, supervising or officiating in an organized youth sports program or recreation, playground or camp activity, shall not jeopardize an athlete's amateur status.
  - Reasonable compensation derived from private lessons in a sport is permissible.
- 1.92 An athlete **forfeits amateur status** in a sport by:
- competing for money or other monetary compensations except for reasonable allowances for travel, meals, and lodging. NOTE: Accepting expense allowances authorized by the United States Olympic Committee for Olympic Development Programs is acceptable for GHSA students.
  - receiving any award or prize of monetary value which has not been approved by the GHSA.
  - capitalizing on athletic *performance* by receiving money or gifts with monetary value except college scholarships.
  - signing a professional playing contract in any sport, or hiring an agent to manage his/her athletic career.
- 1.93 Only **awards** approved by the GHSA may be accepted by a high school student-athlete as a result of participation in school or non-school competition in a sport recognized by the GHSA.
- 1.94 **Symbolic awards** (i.e. non-cash) presented for winning or placing in GHSA competitions are limited to \$400 per year, per student in the aggregate, paid by the local school. These are the only GHSA-approved awards for interscholastic competition. Beyond this, a student may receive one (1) school sweater or jacket presented by the school during his high school career.
- 1.95 Athletes competing in golf or tennis events are limited to awards as specified in the United States Golf Association Rules of Golf, and the United States Tennis Association Handbook of Tennis Rules and Regulations, which includes (but not limited to) the following:
- No cash awards may be accepted.
  - Merchandise awards in tennis may be accepted up to a retail value of \$250.00.
  - Merchandise awards in golf may be accepted up to a retail value of \$750.00.
- 1.96 Players attending national camps or all-star events may keep reasonable benefits for housing, meals and transportation. Players may keep only equipment that is commemorative in nature and/or used in the process of the event's workouts.
- 1.97 *Students may receive consideration for the use of their own name, image and likeness (NIL). Guidance for NIL can be found in Appendix "N" of the GHSA Constitution.*

## BY-LAW 2.00 - SCHOOL

### 2.10 - SCHOOL MEMBERSHIP TO GEORGIA HIGH SCHOOL ASSOCIATION

- 2.11 **The GHSA is a voluntary association** available to any Georgia high school, grades 9-12, that has been authorized to seek membership by the local board of education or similar governing body of control.
- Member schools agree to **conform to the Constitution and By-Laws of the GHSA.**
  - Member schools agree to **conform to the rules of the region** organizations to which they are assigned.
  - Should a conflict arise between state rules and region rules, the **state rules always take precedent.**
- 2.12 **Procedure for Membership:**
- The local board of education or similar governing body of control must adopt a **resolution authorizing membership** for the high school.
  - Membership is continued through the original resolution as long as the school is in good standing with the GHSA.

- (c) April 1 preceding the reclassification alignment process is the deadline date for new and existing private schools to join the GHSA for the next reclassification period. Newly established public schools will have a deadline date of April 1 to join the GHSA for the upcoming school year. No private school with an actual numerical enrollment of less than 150 students in grades 9-12 will be admitted to the GHSA.
- (d) Converted charter schools whose attendance zones and eligibility requirements do not change retain their membership in the GHSA. Converted charter schools or startup charter schools must apply for membership in the GHSA.

### 2.13 Dues for Membership:

- (a) The amount of the dues is **set annually** by the Executive Committee of the GHSA, and includes a portion of the cost of **catastrophic insurance**.
  - (1) Dues must be paid prior to October 15 of each year.
  - (2) Schools failing to meet the dues-payment deadline are not eligible to participate in any contest until membership dues are paid.
- (b) Dues are prorated according to the school's classification.  
NOTE: Schools with a total enrollment of less than 50 students are assessed their insurance fees according to the actual number of participants.
- (c) The Dues schedule is as follows:

| CLASSIFICATION | PAID BY OCTOBER 15 | PAID AFTER OCTOBER 15 |
|----------------|--------------------|-----------------------|
| 7A             | \$1,115.00         | \$1,215.00            |
| 6A             | \$990.00           | \$1,090.00            |
| 5A             | \$865.00           | \$965.00              |
| 4A             | \$740.00           | \$840.00              |
| 3A             | \$615.00           | \$715.00              |
| 2A             | \$490.00           | \$590.00              |
| A              | \$365.00           | \$465.00              |

- 2.14 If a school or school system initiates litigation against the association and the court rules in favor of the association, the school or school system shall be responsible for paying all court costs and attorneys' fees.
- 2.15 If the association conducts an investigation of a member school in reference to a possible violation of association rules and the member school is found to be in violation, the school shall be assessed the cost of the investigation in addition to any fines.
- 2.16 **Playing a Non-Region Schedule:** A school may choose to play a non-region schedule in football, fastpitch softball, basketball, and/or baseball, and this choice is in effect for the current reclassification cycle.
  - (a) A school playing a non-region schedule may not participate in post-season competition.
  - (b) Results of games with a school playing a non-region schedule may not be used in region standings.
  - (c) Schools playing a non-region schedule in football, fastpitch softball, basketball and/or baseball must inform the GHSA office not less than 30 days prior to the first official playing date for that sport.
- 2.17 **Region and Area Divisions:** A classification in any sport will be considered Regionalized when a majority of the schools (with a minimum of 5) in all regions participate in that sport. In sports where all classifications are not regionalized, the classes may be divided into Area alignments, and two or more classifications, or any portions thereof, may be combined at the discretion of the Executive Director. NOTE: Regions formed by the Reclassification Committee that consist of fewer than five (5) teams may be exempted from this rule.

## 2.20 - ADMINISTRATIVE RESPONSIBILITIES

- 2.21 The administrative head of each school shall have on file in the school office:
  - (a) a certificate of an **annual physical examination** given by a licensed medical physician, a doctor of Osteopathic medicine, nurse practitioner or a physician's assistant indicating the student is approved for participation in athletic activities before that student may try-out, participate in practice, conditioning drills or summer activities, or participate in interscholastic contests (see By-Law 1.41).
  - (b) a written **Emergency Action Plan** for athletic practices and games. This plan must include responses to natural disasters, serious illnesses/injuries, and terroristic events, and must have the involvement of local law enforcement agencies, rescue agencies, medical doctors and hospital personnel.
  - (c) The **Emergency Action Plan** (EAP) should include the following:
    - (1) The venue-specific EAP should be reviewed and rehearsed annually prior to each sport season. Recommended personnel include local Emergency Medical Services (EMS), school public safety officials, school administrators, on-site medical personnel or school medical staff (team physicians or athletic trainers) and all pertinent coaching staff members.
    - (2) The venue-specific EAP and AED should be accessible to all involved in a potential emergent situation for practices, games or other athletic events.
    - (3) All emergency equipment which is available onsite, including Automatic External Defibrillators (AEDs), should be listed on the EAP, stored in a safe place, be well-marked and publicized.



- (4) The EAP should identify key personnel and their responsibilities to carry out the plan of action with a designated chain of command, including documentation actions that need to be taken post emergency.
  - (5) The EAP should contain appropriate contact information for the local and/or responding EMS personnel.
  - (6) The EAP should contain the facility address, GPS coordinates, location and contact information.
  - (7) A medical timeout is recommended prior to all GHSA sanctioned events to review the EAP.
- 2.22 The administrative head of each school shall **operate** all interscholastic **contests and activities** under direct and complete control of the school administration or designated school personnel. These responsibilities are not to be delegated by the board of education, superintendent, or principal to any person or persons who are not a part of the school's professional staff.
- 2.23 The administrative head of each school is expected to be a person who believes in fairness and honesty as evidenced by the **strict adherence to all rules** and regulations in regards to eligibility of contestants representing his/her school.
- 2.24 The administrative head of each school is expected to employ those persons who exemplify fairness and honesty. Any certificated person who violates rules in regard to student eligibility, or illegal practices, or knowingly misleads a member school and/or the GHSA will have a report of that behavior sent to the Professional Standards Commission.
- 2.25 The administrative head of each school may submit to the GHSA Executive Committee such **recommendations for the improvement of the GHSA** as he/she may deem necessary.
- (a) These recommendations must be submitted to the GHSA Office at least thirty (30) calendar days prior to the meeting of the Executive Committee.
  - (b) A proposal brought to the Executive Committee that is denied by either a subcommittee or the full Executive Committee may not be submitted for three (3) regularly-scheduled meetings after the previous submission unless a substantive change has been made to the proposal.
- 2.26 The member institution has a responsibility to educate student-athletes, coaches, and other appropriate persons on GHSA rules and procedures that could affect them. Further, the member school should monitor its compliance with State Association guidelines.
- 2.27 Member schools that fail to follow stated procedures and deadlines may be assessed a fine for each violation.
- 2.28 Schools that need to cancel appointments scheduled with the Hardship Committee or the Appeals Board must do so at least 24 hours before the appointment. Failure to cancel properly will result in a fine.
- 2.29 Member schools are expected to fulfill their responsibilities for a sports season once they have committed to play that sport.
- (a) If a school commits to play a sport at the region meeting that precedes the sport, or on March 1 for Area sports, and then drops out of competition before or during the season, the school will have to play a non-region schedule in that sport the next year.
  - (b) If a school enters the competitive structure that qualifies it to advance in postseason competition, that school is expected to advance if it qualifies. Schools that drop out of competition after qualifying may be penalized with fines or probation.
  - (c) Appeals for emergency circumstances may be filed with the Executive Director.

## 2.30 - ELIGIBILITY REPORTS FILED BY THE SCHOOL

- 2.31 **Eligibility reports** are required for all contestants prior to the calendar date for the first possible practice in any GHSA activity. (EXCEPTION: Eligibility reports for Literary, One-Act Play and Riflery competitions are due twenty (20) calendar days before the first contest.)
- (a) Students are not allowed to participate in academic, athletic or literary competitions until their eligibility reports have been received and processed by the GHSA Office.
  - (b) Failure to meet the eligibility deadline may lead the GHSA Executive Director to:
    - (1) Assess a fine to the school that is delinquent.
    - (2) Suspend the membership of a school that does not file eligibility reports.
  - (c) Reports not filed properly will be returned to the school for resubmission.
- 2.32 Schools **playing interscholastic contests before filing an eligibility report** on one or more participating students may be subject to one or more of the following penalties imposed by the GHSA Executive Director:
- (a) a fine per game or contest in which one or more participants had no eligibility report filed;
  - (b) forfeiture of any game in which one or more participants did not have eligibility report filed;
  - (c) restriction from competition in any sport if the fines assessed are not paid within fourteen (14) calendar days of notification.

- 2.33 **Supplementary eligibility reports** may be submitted at any time on transfer students, students coming out for the team after the initial report, and/or those students who gain eligibility at the beginning of a semester.
- 2.34 Once a student has been certified eligible by the school and has been processed by the GHSA, **eligibility is assumed to be continuing**, and no further eligibility report is necessary for that student during the school year unless situations occur that render the student ineligible.
- 2.35 If a student **loses eligibility and regains** it during the school year, a new eligibility report should be filed for that student.
- 2.36 **Changes of Eligibility Records:** When a school discovers that incorrect information has been given on an eligibility report, the school should contact the GHSA office for procedural instructions.
- 2.37 Requests to investigate a student's eligibility in regard to the transfer rule must be filed with the GHSA office at least twenty (20) calendar days before the end of the regular season in order for any penalties to be applied before the end of the playoffs.

## 2.40 - STUDENT RETENTION FOR INTERSCHOLASTIC ATHLETIC ACTIVITIES

- 2.41 Member schools shall prohibit participation in interscholastic activities by any student who was **retained in the eighth grade for competitive purposes**. The governing body of each school system shall develop a written policy showing that the system does not allow retention for competitive purposes.

## 2.50 - QUALIFICATIONS TO COACH

- 2.51 An athletic head coach must be a professional teacher, or hold a four-year degree while also employed in a teaching or administrative position, **meeting the teaching requirements and be employed** by only one board of education or similar governing authority within the GHSA membership, regardless of whether or not they are paid for their coaching (Exception: when all boards of education or similar governing authorities and all principals/headmasters involved sign a consent form on an annual basis he/she may coach at another school system), AND:
- be employed for 20 or more hours per week on a regular basis in a professional, contracted position and must hold a **teaching certificate or leadership certificate** issued by the State of Georgia, OR
  - be employed for 20 or more hours per week on a regular basis as a **JROTC instructor** in the school's JROTC program, OR
  - be assigned as a **student intern** in a practice teaching situation under the guidance of a college or university teacher training program, OR
  - be a **retired teacher** teaching or supervising (NOTE: coaching meets the supervising requirement of this by-law) less than one-half time (forty hours considered full time), OR
  - be a certified teacher or administrator at a member school on medical leave governed by the "Family Medical Leave Act" and/or the "Georgia Teacher Maternity Leave of Absence" policy (see the GHSA web site for the required form).
  - If a currently certified faculty-coach at a member school loses his/her teaching position because of a reduction in force action, that school may petition the Executive Director in writing for that individual to continue to coach without going through the community coach training.
  - A teacher at a non-member school who is hired to be a coach at a member school **must** complete the GHSA Community Coach Education program and may **not** be a head coach. A consent form between the two schools must be completed annually.
  - If a school is in a charter or strategic waiver (IE<sup>2</sup>) system, the coach (head coach or assistant) must meet the highly qualified requirements outlined in the Georgia Professional Standards Commission's guidelines.
- 2.52 Member schools may employ persons who are not professionally certificated teachers as assistant coaches in their athletic programs. These individuals are referred to as "**community coaches**."
- Community Coach is defined as a person who does not have a professional-level certification, who relates in role and function to a professional and does a portion of the professional's job or tasks under the supervision of the professional, and whose decision-making authority is limited and regulated by the professional. Community coaches are not allowed to function without the immediate supervision of an educational professional and may not assume any of the duties of a varsity Head Coach or be named by the school as a varsity Head Coach.
  - Licensed para-professionals and full-time substitute teachers must complete the GHSA Coaches Education Program and testing program to be eligible to coach.
  - All community coaches should be signed to a written "agreement to coach."
    - They may coach for only one board of education annually, regardless of whether or not they are paid for their services.

- (2) Community coaches may not coach the same sport at more than one school even if there are multiple schools in the system.
  - (d) All community coaches must complete the **GHSA Coaches Education Training and Testing Program** in “Sport First Aid” and “Principles for Coaches.”
    - (1) Prospective coaches must be subject to a criminal background check before they are registered for the GHSA coaches education program.
    - (2) Courses are offered at various times each school year throughout the state.
    - (3) Prospective coaches are registered with the GHSA office by the school hiring them.
    - (4) No community coach may do any GHSA coaching until he/she has been notified that the GHSA Coaches Education Program had been completed successfully.
  - (e) It is recommended that the following **priority for employment** be used:
    - (1) certified employees in the local system (secondary, middle, elementary, central office, etc.);
    - (2) retired certificated personnel;
    - (3) community coaches who have completed the GHSA Coaches Education Program.
  - (f) All community coaches must attend a regular GHSA rules clinic each year for any sport in which they coach beginning with their first year of service or the school will be fined.
  - (g) No person who has coached a non-GHSA team in a sport or activity within the previous 12 months may be hired or utilized by a GHSA member school in that same sport or activity IF any of that GHSA school’s players participated on the non-GHSA team that person coached.
- 2.53 GHSA member schools must **register** all coaches in **all** GHSA governed activities according to the following:
- (a) An initial directory listing of administrators and coaches must be completed and filed with the State Office by August 1 of each year. Only professionally certificated personnel, or individuals holding a four-year degree who are employed in a teaching or administrative position, are to be included on the initial directory listings.
  - (b) **Qualified** Community Coaches are to be reported on the “School Staff Roster” on the GHSA web site. Only those persons who have successfully completed the **GHSA Coaches Education Program** are to be listed. NOTE: Schools must verify the successful completion of the coaches education program BEFORE community coaches are submitted to the GHSA and BEFORE any coaching activities are allowed (forms on the GHSA web site).
  - (c) After August 1, schools will have occasion to add members to their coaching staff. It is the responsibility of the member school to register these additions in a timely manner, using the School Staff Roster on the GHSA web site.
  - (d) Failure to comply with these procedures could result in punitive actions including, but not limited to, fines, forfeitures and other penalties assessed to the member school.
- 2.54 **Every faculty coach, community coach, or student-teaching intern at a member school must complete:**
- (a) **a GHSA-sponsored rules clinic** if he/she coaches the following sports or activities: cross country, football, softball, volleyball, riflery, literary, esports, one act play, cheerleading (spirit and/or competitive), basketball, lacrosse, wrestling, swimming and diving, track, baseball, golf, soccer and gymnastics.
  - (b) **CPR (minimum compression only) and AED training** prior to any team activity or within a maximum of 30 days from the start of a team activity and it must be renewed at a minimum of every two years.
  - (c) *All coaches must attend/complete a comprehensive training and education program for “Traumatic Head Injuries.” The recommendation is the CDC “Heads Up” for coaches.*
- NOTE:** A fine for each coach who does not complete a rules clinic, or who does not complete the required CPR, AED or concussion management training, before the assigned deadline will be assessed to the school.
- 2.55 A **coach** on the payroll of one school district, but under contract to another school district for the following year, may help with **spring practice** at the new school if arrangements are satisfactory with both systems.
- 2.56 An assistant or head coach at a GHSA member school may register and officiate a sport in which they coach with the following provisions:
- (a) They may officiate a sub-varsity contest at any GHSA member school.
  - (b) They may officiate at the varsity and/or post-season level, if the game does NOT involve schools in the same classification as the school at which they coach.

## 2.60 - INTERSCHOLASTIC CONTESTS AND PRACTICES

- 2.61 All **practices** (team and individual) and all **regular-season interscholastic contests** for GHSA-member schools shall be **conducted outside the school day of the participants’ school**.
- (a) Regional, Sectional, and/or State **playoffs are exempt** from this rule.
  - (b) The “**school day**” is **defined** as: that period of time between when students are required to report to school and the time of dismissal of that school. EXCEPTION: When the host school is not in session on a given day, competitions may be scheduled earlier than normal dismissal time for the host school. However, any school that is in session on that day may not compete in that event before the normal dismissal time of that school.

- (c) A player who participates in a GHSA sport may not participate in practices that occur during the school day. Practice is defined as any activity that is school-initiated, organized, coordinated or supported.
  - (d) All practices will have a maximum length of 3 hours.
  - (e) A maximum of two (2) practice sessions may be held in the same day. When multiple sessions are held, the maximum practice time is extended to five (5) hours. Sessions must be separated by a three (3) hour rest break in a cool environment and this rest break cannot include weightlifting or conditioning. When a double session practice day occurs, the following practice day must be a single session day. (Football contact guidelines must be followed)
  - (f) Football participants complete the five (5) day acclimatization period that starts five (5) weekdays prior to the first official day of practice of each calendar year.
- 2.62 The GHSA shall provide **rules and regulations for competition** among member schools for those competitive activities listed in the GHSA Constitution and By-Laws.
- (a) Member schools may be allowed to schedule and play **GISA** and **GAPPS (formerly GICAA)** member schools provided the principal or athletic director of each agrees in writing, utilizing the standard “GHSA Cross-Play Contract,” available on the GHSA web site ([www.ghsa.net](http://www.ghsa.net)).
    - (1) GISA and GAPPS schools competing with GHSA schools must comply with all GHSA safety rules and requirements, and must be in compliance with Official Code of Georgia Sections 20-2-319.2 relating to pre-participation physical exams and 20-2-324.1 relating to concussion management protocols.
    - (2) Participants must be in compliance with all eligibility rules of their respective associations with the exception that only those participants in grades 9-12 shall be allowed to participate.
    - (3) Such competition shall not be counted nor the results considered toward GHSA post-season competition.
  - (b) In situations not covered by section (a), member schools shall **compete, practice or scrimmage only against other member schools** or against schools that are full members of the State Association in their respective states (NOTE: Football games may be scheduled only if the opponent is a full member, without restrictions, of its state athletic association). When competing internationally, member schools may compete only against school teams in that nation that are composed of students of similar ages. International exhibition competitions or scrimmages are not allowed. NOTE: When member schools compete out of state, the host state’s adaptations of NFHS playing rules will be enforced, and all GHSA by-laws regarding sportsmanship, eligibility and game times will be enforced.
  - (c) Member schools are **permitted to compete against non-member schools** in activities not listed in the GHSA Constitution and By-Laws.
  - (d) The GHSA Executive Director has the authority to approve competition between GHSA schools and **private schools from states in which membership in the State Association is not allowed**. These non-member schools must meet or exceed the State Association standards in order to compete with GHSA schools.
  - (e) A member school shall have no more than one varsity, one junior varsity, and one 9th grade team.
    - (1) Any **sub-varsity team** is limited to a maximum number of games equal to 70% of the varsity allotment in that sport. EXCEPTION: New schools that have only 9th and 10 grades with JV teams only (no varsity) are allowed to play the number of games allowed for varsity teams.
    - (2) **Competition between sub-varsity and varsity teams and/or individuals** at the same event is prohibited. An exception may be made by the Executive Director for schools just opening and for schools just starting a particular sport.
    - (3) In the sports of Cross Country, Golf, Swimming, Tennis, Track & Field and Wrestling, a school may use a “**split squad**” at two regular season events on the same day at the varsity or sub-varsity levels. Both of the contests must be counted against the total number of contests allowed in that sport (Exception: Golf – see Golf section). Individual players may not exceed the total number of contests allowed at the varsity level of that sport.
    - (4) **Unattached Competitor**: Individual athletes may participate in non-GHSA events in the sports of Cross Country, Golf, Gymnastics, Riflery, Swimming, Tennis, Track and Wrestling as long as they do not represent their school, do not wear the school uniform, and are not coached at the event, or transported to the event, by their high school coach. “House teams” made up of athletes from various schools competing in a GHSA event are not considered to be unattached competitors and are illegal.
    - (5) No athlete will be allowed to compete in a GHSA game or contest (even in post-season play) unless accompanied by certified professional school personnel whose names have been submitted to the GHSA as coaches. Those students chaperoned by someone other than a certified professional will **not** be allowed to compete.
    - (6) In any GHSA sport, there may be no “**open**” competitions or exhibition performances that extend participation beyond the three levels of competition (i.e., varsity, JV, 9th grade) mandated in this by-law. The only interscholastic contests in which results are disregarded are scrimmages as defined below.
    - (7) **Drones** shall not be permitted to fly during any GHSA sanctioned contest. Note: This prohibition begins when the gates or doors open and extends until the last spectator has left the field or arena.

- (8) **Live Animals** are prohibited at any indoor GHSA event unless a signed permission letter is acquired from the principal of the school wishing to bring the animal and the principal of the host school (if different). A copy of this letter must be provided to the GHSA office. NOTE: This by-law does not pertain to certified service animals.
- (f) One **interscholastic scrimmage** (two teams meeting head-to-head) is allowed in the sports of Baseball, Basketball, Football, *Flag Football*, Lacrosse, Soccer, Softball, Volleyball and Wrestling (tri match allowed on days preceding school or quad match on days not preceding a school day).
  - (1) This scrimmage may be scheduled anytime between the beginning of practice as set by the GHSA and the first regular season game for each team.
  - (2) This scrimmage is for varsity teams only, and shall be played with normal timing and/or scoring rules except as noted in individual sports sections.
  - (3) Officials registered with GHSA must be assigned, and the GHSA "Fee Chart" must be followed.
  - (4) A school may not scrimmage another school that is counting the scrimmage as a regular-season contest.

2.63 **Written contracts** are **required** for all baseball, football, basketball, wrestling and fastpitch softball contests, and are strongly **recommended** in all other interscholastic contests that are scheduled between member schools.

- (a) Contract forms can be found on the GHSA web site.
- (b) Contracts are also recommended for all sub-varsity contests.
- (c) GHSA-member schools are expected to fulfill the conditions of any game contract that has been properly executed.
  - (1) Exceptions to the contract may be made with the agreement and consent of both schools.
  - (2) Member schools that fail to fulfill the requirements of a scheduled event may be required to make **restitution** to the competing school if that school is unable to secure an opponent (This includes multi-school events). The offended school shall petition the Executive Director for the desired restitution.
  - (3) Schools failing to fulfill a game contract may be **suspended** in that sport for one (1) full calendar year or the corresponding date of the next calendar year, whichever is greater.
  - (4) **EXCEPTION:** The GHSA Executive Director may excuse the failure to fulfill a game contract if, in his opinion, the circumstances causing the failure were outside the control of the school officials.
- (d) All athletic events hosted by GHSA-member schools (except Cross Country, Golf, Riflery, Tennis and Track) shall be officiated at all levels of competition by **officials** who are members of associations that are approved by the GHSA. (Exception: situation noted in By-Law 2.95).
  - (1) Officials' associations and their assigned schools shall include the method of payment in their contract.
  - (2) It is recommended that the same number of officials be used in regular-season competitions as the number used in playoff competitions in that sport.
- (e) **Forfeiture and Restitution Policy**
  - (1) If a team does not arrive at the game site for any contest without notifying the host opponent of a late arrival, that contest will be forfeited 30 minutes after the scheduled game-time. If the second game or contest was to be played by a different team (EXAMPLE: girl/boy or JV/varsity combination events), then a decision to forfeit that game will be made 30 minutes after the scheduled beginning of the second game.
  - (2) If there are to be multiple games by the same team and the team does not arrive at the game site without notifying the host opponent of a late arrival, all games will be forfeited 30 minutes after the scheduled game-time of the first contest. EXAMPLE: softball or baseball doubleheaders
  - (3) If a school fails to show up for a game or cancels a game within twenty-four (24) hours of the scheduled starting time without an emergency condition or weather-related conditions, that school shall pay a forfeiture fee to the host school equivalent to the cost of the officials. NOTE: If the host school is the violating team, the fee will be paid directly to the officials association. The host school shall reimburse the visiting team(s) for mileage incurred by the visiting team(s) when this by-law is violated by the host team).
  - (4) If a school fails to show up for a game or cancels within twenty-four (24) hours of the scheduled game time without emergency reasons or weather-related reasons for a second time, that school must make restitution again and must show cause to the GHSA Executive Director as to why they should not be placed on probation by the GHSA.
- (f) The minimum penalty for allowing an ineligible athlete to participate in an interscholastic contest is forfeiture of the game(s). Fines or other penalties may also be imposed. NOTE: If it is determined by the Executive Director that the school has exercised every reasonable precaution and has been deceived regarding the student's data, any or all penalties may be set aside.
- (g) A team shall forfeit any team standing or points toward team honors when an ineligible student participates in a contest. In sports where individual titles may be won (Cross Country, Literary, Riflery, Swimming & Diving, Traditional Wrestling, Gymnastics, Golf and Track), eligible individuals will keep their placements and opportunities to advance toward individual honors even if a teammate participated while ineligible.

- 2.64 **Tournaments or multiple-meets**, other than the Region or State elimination series must be approved (**sanctioned**) by the GHSA Executive Director, subject to the special conditions for athletics and/or other activities.
- (a) A GHSA-member school shall not enter a tournament which requires sanctioning until that tournament has been **approved by the GHSA Executive Director**.
    - (1) The GHSA Executive Director may assess a fine and/or other penalties against a member school that violates the sanctioning rules.
    - (2) Member state championship teams receiving an invitation to nationally-recognized tournaments held after the designated sports season has ended must apply to the Executive Director for approval. Such application must be signed by the principal of the school, must be submitted at least 14 calendar days prior to the beginning of the tournament and must include the following: contact information for the tournament organizer; proposed plans for the school to include manner and date of travel; number of hours of instruction to be missed and fees to participate. A decision not to approve may be appealed to the GHSA Board of Trustees, who shall review the information submitted to the Executive Director. No additional information or documentation shall be considered. The vote of the majority of the Trustees shall control.
    - (3) **Tournament participation limits** are set for each sport, and they are listed in the specific sport sections in this document.
  - (b) All **applications for sanctioning** must be submitted to the GHSA thirty calendar (30) days prior to the tournament by a GHSA-member school.  
NOTE: Tournaments that require National Federation sanctioning are an exception to this rule.
  - (c) The host school for all sanctioned tournaments shall **pay five percent (5%)** of all gross gate receipts **to the GHSA** within fourteen (14) calendar days after the tournament.
    - (1) Total gate receipts before expenses are paid equals the gross receipts.
    - (2) A financial report of the event shall accompany the payment.
  - (d) GHSA approval for **tournaments in contiguous states** is needed when there are four or more schools participating.
  - (e) Approval for **tournaments in Georgia** is needed when:
    - (1) it is a tournament involving four or more schools OR
    - (2) it is a tournament in which awards are given.
  - (f) Tournaments that require **approval from the National Federation** are:
    - (1) any interstate tournament in which more than eight schools participate, and at least one participant is from a non-contiguous state OR
    - (2) any interstate tournament that involves schools from five (5) or more state High School Associations, and at least one of them does not border on the State of the sponsoring school OR
    - (3) any international tournament (except competition with Canadian and Mexican high schools) OR
    - (4) any interstate tournament involving two (2) or more schools which is co-sponsored by or titled in the name of an organization outside the high school community (e.g., a university, a theme park, an athletic company).
  - (g) The GHSA Executive Director has the authority to approve competition between GHSA schools and **private schools from states in which membership in the State Association is not allowed**. These non-member schools must meet or exceed the State Association standards in order to compete with GHSA schools.
  - (h) In all sports except Football, a team (subvarsity or varsity) may play multiple games on a single calendar day in a tournament setting. NOTE: In these instances, the special "quarter/half participation rules" in basketball and soccer are waived. When playing multiple games in a single day in Basketball, Soccer and Lacrosse, there must be at least a four (4) hour scheduling interval between games.
  - (i) For any one-day event in which more than two schools compete (i.e., a basketball showcase or some similar event), the following stipulations are in effect:
    - (1) A "host school" must be designated for each game even if the games are played at neutral sites.
    - (2) The host school must provide a Game Manager for that game.
    - (3) The host school must schedule game officials through the local association assigned to it.
    - (4) These special events will require sanctioning approval from the GHSA office.
- 2.65 **Available Seating:** Member schools shall provide a seat for each ticket sold to any contest regulated by the GHSA.
- (a) An available seat is defined as twenty-four (24) inches in width.
  - (b) Each school is required to make a determination of the available seats prior to the beginning of the contest.
  - (c) At outdoor events, "standing room" tickets may be sold as long as they are identified as such at the time of the purchase, and as long as there are no problems with safety and security with such an arrangement.
- 2.66 **Weekday Contests:**
- (a) Teams playing any regular season contest when there are classes the next day shall be limited to a travel distance of no more than 100 miles one way as determined using the maps program at [www.Yahoo.com](http://www.Yahoo.com).

- (b) No contest shall be played beyond 11:30 p.m., unless exempted under By-Law 2.93 (c2b) or by procedures found in sections of the by-laws dealing with specific sports. A petition may be filed with the Executive Director to waive the 11:30 p.m., curfew for teams of different classifications or competitions with out-of-state teams when there are special circumstances.

**2.67 Practice Policy for Heat and Humidity:**

- (a) Schools must follow the statewide policy for conducting practices and voluntary conditioning workouts (this policy is year-round, including during the summer) in all sports during times of extremely high heat and/or humidity that will be signed by each head coach at the beginning of each season and distributed to all players and their parents or guardians. The policy shall follow modified guidelines of the American College of Sports Medicine in regard to:
  - (1) The scheduling of practices at various heat/humidity levels.
  - (2) The ratio of workout time to time allotted for rest and hydration at various heat/humidity levels.
  - (3) The heat/humidity levels that will result in practice being terminated.
- (b) **Football Only:** Acclimatization and Re-Acclimatization (prior to October 1st)
  - (1) Acclimatization
    - a. Football practice may begin five consecutive weekdays prior to the start date for football.
      - 1. In the first five days of practice for any student, the practice may not last longer than two (2) hours, and the student may wear no other protective football equipment except helmet and mouthpieces. NOTE:
        - (a) The time for a session shall be measured from the time the players report to the practice or workout area until they leave that area.
        - (b) During acclimatization practices, teams may hold a walk-through as long as there is at least a three-hour break between the two activities.
    - (2) Re-Acclimatization – Required for any athlete who misses five (5) consecutive days of practice for any reason.
      - a. Day 1: 1.5 hours conditioning - helmets only
      - b. Day 2: 2 hours practice - helmets only
      - c. Day 3: 2.5 hours practice with helmets and shoulder pads
      - d. Day 4: 2.5 hours practice with full pads
      - e. Day 5: 2.5 hours practice with full pads or play a game
  - (c) A scientifically-approved instrument that measures the Wet Bulb Globe Temperature must be utilized at each practice (prior to October 1) to ensure that the written policy is being followed properly. WBGT readings should be taken at a minimum of every 30 minutes, beginning 30 minutes prior to the start of practice. All WBGT monitors shall be calibrated, at a minimum, every two (2) years or earlier if recommended by the manufacturer.

---

**WBGT    ACTIVITY GUIDELINES AND REST BREAK GUIDELINES**

---

|             |   |
|-------------|---|
| Under 82.0  | Normal Activities - Provide at least three separate rest breaks each hour with a minimum duration of 3 minutes each during the workout.   |
| 82.0 - 86.9 | Use discretion for intense or prolonged exercise; watch at-risk players carefully. Provide at least three separate rest breaks each hour with a minimum duration of 4 minutes each.   |
| 87.0 - 89.9 | Maximum practice time is 2 hours. <u>For Football:</u> players are restricted to helmet, shoulder pads, and shorts during practice, and all protective equipment must be removed during conditioning activities. If the WBGT rises to this level <b>during</b> practice, players may continue to work out wearing football pants without changing to shorts. <u>For All Sports:</u> Provide at least four separate rest breaks each hour with a minimum duration of 4 minutes each. |
| 90.0 - 92.0 | Maximum practice time is 1 hour. <u>For Football:</u> no protective equipment may be worn during practice, and there may be no conditioning activities. <u>For All Sports:</u> There must be 20 minutes of rest breaks distributed throughout the hour of practice.   |
| Over 92.0   | No outdoor workouts. If practice has not started, delay the start of practice until a cooler WBGT level is reached.   |

---

- (d) Practices are defined as: the period of time that a participant engages in a coach-supervised, school-approved sport or conditioning-related activity. Practices are timed from the time the players report to the practice or workout area until players leave that area. If a practice is interrupted for a weather-related reason, the "clock" on that practice will stop and will begin again when the practice resumes.

- (e) Conditioning activities include such things as weight training, wind-sprints, timed runs for distance, etc., and may be a part of the practice time or included in “voluntary workouts.” Conditioning activities are not permitted to be used as punishment.
- (f) A walk-through is not a part of the practice time regulation, and may last no longer than one hour. This activity may not include conditioning activities or contact drills. No protective equipment may be worn during a walk-through, and no full-speed drills may be held.
- (g) Rest breaks may not be combined with any other type of activity and players must be given unlimited access to hydration. These breaks must be held in a “cool zone” where players are out of direct sunlight.
- (h) When the WBGT reading is over 86, ice towels and spray bottles filled with ice water should be available at the “cool zone” to aid the cooling process AND cold immersion tubs must be available for the benefit of any player showing early signs of heat illness. In the event of a serious EHI, the principle of “Cool First, Transport Second” should be utilized and implemented by the first medical provider onsite until cooling is completed (core temperature of 103 or less).

#### 2.68 GHSB Concussion Policy and SB 60, Sudden Cardiac Arrest Prevention Act

- (a) **GHSB Concussion Policy:** In accordance with Georgia law and national playing rules published by the NFHS, any athlete who exhibits signs, symptoms or behaviors consistent with a concussion shall be immediately removed from the practice or contest and shall not return to play until an appropriate health care professional has determined that no concussion has occurred. (NOTE: An appropriate health care professional may include: licensed physician (MD/DO) or another licensed individual under the supervision of a licensed physician, such as a nurse practitioner, physician’s assistant, or certified athletic trainer who has received training in concussion evaluation and management).
  - (1) No athlete is allowed to return to a game or practice on the same day that a concussion (1) has been diagnosed OR (2) cannot be ruled out.
  - (2) Any athlete diagnosed with a concussion shall be cleared medically by an appropriate health care professional prior to resuming participation in any future practice or contest. The formulation of a gradual return to play protocol shall be a part of the medical clearance.
  - (3) Any athlete who has been diagnosed with a concussion must fully return to school (if in session) for a full day prior to returning to practice.
  - (4) Each school will be responsible for monitoring the participation of its coaches in the concussion management course, and shall keep a record of those who participate.
  - (5) Each school must distribute to every athlete and his/her parent/guardian an information sheet that includes: the dangers of concussion injuries, the signs/symptoms of concussion, and the concussion management protocol outlined in this by-law. This sheet must be signed by the parent/guardian of each athlete and a copy kept on file at the school.
- (b) *Any student-athlete who has sustained and has been diagnosed with a traumatic head injury (concussion), must follow a minimum of a 5-step return-to-play protocol. Recommendation for this RTP is based on an athlete completing the following return-to-sport strategy once they have become “symptom free” as determined by an appropriate healthcare professional. A minimum of 24-48 hours of both physical and cognitive rest must take place once the diagnosis is made:*
  - Level 1: Activity – “activities of daily living” that do not cause symptoms to re-occur (gradual return to school)*
  - Level 2: Activity – Light aerobic activity such as walking or stationary bicycle (at a low pace with no resistance)*
  - Level 3: Activity - Running drills, sport-specific activity without head impact*
  - Level 4: Activity – Intensity of training drills may be increased. Limited practice with non-contact drills. Progressive resistance training may begin.*
  - Level 5: Activity – Full medical clearance by a healthcare professional, unrestricted training activities including contact drills may begin*
  - Level 6: Activity – Unrestricted participation to sport*

*A minimum of 24 hours must take place before progression to the next level.*
- (c) **SB 60, Jeremy Nelson and Nick Blakely Sudden Cardiac Arrest Prevention Act:** In accordance with Georgia law:
  - (1) Each school must distribute to every athlete and his/her parent/guardian an information sheet that includes: the Early Warning Signs, How to Recognize Sudden Cardiac Arrest, and Learn Hands-Only CPR outlined in this by-law. This sheet must be signed by the parent/guardian of each athlete, each athlete and a copy kept on file at the school.
  - (2) Each school must hold an informational meeting twice per year regarding the symptoms and warning signs of sudden cardiac arrest. At such informational meeting, an information sheet on sudden cardiac arrest symptoms and warning signs shall be provided to each student’s parent or guardian. In addition to students, parents or guardians, coaches, and other school officials, such informational meetings may include physicians, pediatric cardiologists, and athletic trainers.



- 2.69 **Legal practice dates** are established for each activity (see the calendar at the beginning of this publication), and schools shall not conduct or allow an **illegal practice**.
- (a) The **beginning of each GHSA school year** is designated as August 1st. The **end of the GHSA school year** is designated as when an individual school ends its classes in the Spring.
  - (b) **Illegal practices** are **defined** as practices involving five or more students participating in any extracurricular activity in the presence of, or under the direct or indirect supervision of any coach of the school (including a community coach). **At any given point in time**, only one (1) coach in a sport may work with up to four (4) athletes in skill-building drills.
    - (1) Any practice occurring after the beginning of the school year and **before the opening of the designated season** is an illegal practice.
    - (2) Any practice occurring **after the end of the season** for that team and before the end of the school year for students in that school is an illegal practice.
    - (3) **During the summer** (i.e., between the ending of one school year and the beginning of the next) the only restrictions on practices and competition are that all activities must be strictly voluntary, and two (2) **“Dead Weeks”** must be observed, as follows: Schools are prohibited from participating in voluntary workouts, camps and/or clinics, weight training or competitions during the week (Monday through Sunday) beginning with Memorial Day in May, AND the week (Monday through Sunday) in which the Fourth of July falls each year.
    - (4) It is illegal for a team to go to a competitive or instructional camp or clinic during the school year.
      - (a) If the event is held out of season, it would constitute an illegal practice.
      - (b) If the event is held in-season, it would involve illegal coaching.
      - (c) Boys and girls teams in the same sport are considered the same activity.
      - (d) This prohibition does not apply to the summer months.
    - (5) Neither coaches, former coaches (including community coaches), nor any other school personnel shall suggest, require, or otherwise **attempt to influence students** to participate in or practice for a sport outside the GHSA-designated season. (NOTE: This would prohibit requiring any student to participate in one sport in order to be allowed to try-out and/or play another sport at his school).
    - (6) The following activities are **examples of illegal practices**:
      - (a) interscholastic scrimmages or practice competitions not in compliance with By-Law 2.62e;
      - (b) practices involving alumni or students who presently are not eligible at the member school at any time in the school year;
      - (c) practices against a non-school team at any time in the school year;
      - (d) practices of any kind outside the season designated by the GHSA.
- NOTE: Free Style and Greco-Roman Wrestling are considered to be the same sport as Folk Style (high school) Wrestling and are subject to GHSA rules regulating illegal practices.
- (7) Coaches are allowed to be spectators (in the stands) or “fellow competitors” at non-school events out of season as long as no coaching occurs.
  - (8) Schools found guilty of having illegal practices will be subject to **penalties** that may include a fine, warning, probation, and/or suspension by the GHSA Executive Director.
- (c) A GHSA coach (certified teacher or community coach) may not coach a non-GHSA team in a competitive setting during the school year that includes any player(s) who participate in the sport he/she coaches at the member school. EXCEPTION: In a situation in which the child or step-child of the coach is the only player on a non-school team from the coach’s school, the coach would be exempted from this rule.

## 2.70 - SPORTSMANSHIP

- 2.71 GHSA-member schools are required to conduct all relationships with other schools in a **spirit of good sportsmanship**.
- (a) It shall be the responsibility of a member school to use every means at its disposal to impress upon faculty, students, team members, coaches, and spectators the **values of sportsmanship** in preparation for the management of interscholastic contests. Contest officials have the authority to have any and all individuals removed from the confines of the contest whose behavior has become a distraction and/or hindrance to the administration of the event. This may include, but is not limited to, verbal and visual gestures.
  - (b) The Executive Director shall have the authority to assess penalties against schools and/or coaches for conduct unbecoming a professional educator or coach committed by coaches or other school personnel at GHSA events. Penalties against schools may include fines, probation or suspensions; and penalties against coaches and other school personnel may include suspension from GHSA events.
  - (c) It shall be the **responsibility of the home or host school** to take the following precautions at all interscholastic athletic events:
    - (1) Take proper steps and precautions to insure crowd and spectator control, including having an administrator (or designee) from the host school to function as **“Game Manager”** at all GHSA sanctioned events. EXCEPTIONS: Golf and Tennis.
    - (2) Take steps to insure the **comfort and security** of all players, coaches, and officials.

- (3) Have in place sufficient **security personnel** to handle any crowd-control problems that might reasonably be expected.
- (4) Security escorts must be provided to game officials by the host school at all GHSA sanctioned contests, before, during and following the contest - including to their vehicles.
- (5) Provide a safe and secure changing area for contest officials, free from traffic by school staff, students and spectators.
- (d) Each school must develop a **plan to handle fight situations** that may occur during an athletic contest.
  - (1) Attention must be given to keeping **substitutes** in the bench areas throughout the fight, and to keeping **spectators** away from the competitive area.
  - (2) **Schools** whose substitutes leave the bench area to go to the area of a fight will be **fined** by the GHSA Executive Director.
  - (3) All players who are involved in a fight and any substitutes who leave the bench area during a fight or potential fight and are **ejected** from the current contest, will be subject to the sit-out rule.
  - (4) The GHSA office may review film to determine participants in a fight situation, or to determine athletes leaving their bench to go to a fight, or to verify the correct number worn by a player in either of these situations. Note: penalties may then be levied, modified or changed based on this film review.
- (e) Players and coaches are expected to exhibit good sportsmanship before, during and after a contest, even if the game officials do not have jurisdiction. Behaviors such as taunting, fighting, etc., are forbidden.
- (f) No coach may remove his/her team from competition before the end of the contest unless it is done in accordance with the playing rules of that sport.

2.72 Any **player, coach, or team attendant** who is **ejected** from a GHSA contest shall be suspended from all levels of competition (i.e., varsity or sub-varsity) in any sport or activity (regular season or playoffs) until the period of suspension has expired. NOTE: Ejection penalties must be served at the next contest regardless of whether or not the school has received notice from the GHSA office by that time.

- (a) Ejections are based on judgment calls by a contest official and are not reviewable or reversible.
- (b) A coach shall have no role nor be in attendance at pre-contest warm-ups or activities, and shall not be in uniform in attendance at contests until the period of suspension has expired.
- (c) A player or team attendant may not be on the competitive area nor in the team bench area during any contest until the period of suspension has expired, but is allowed to participate (not in uniform) in Senior Night recognition.
- (d) The **period of suspension** resulting from an ejection will expire as follows:
  - (1) **Football:** after the individual has been withheld from the next-scheduled game at the level at which the ejection occurred (and all contests at any other level).
  - (2) **Soccer:**
    - (a) One-Game Sit-out:
      - 1. Two yellow cards in the same game
      - 2. Deliberate handball to prevent a goal
      - 3. Red card for a foul on a player moving toward his goal in a scoring situation
    - (b) Two-Game Sit-out with Red Card for any of the following: taunting, violent conduct, serious foul play, spitting on another person, foul or abusive language, leaving the bench area for a fight situation.
  - (3) **Lacrosse** players who are ejected or foul out will sit out as follows:
    - (a) BOYS: Any player who fouls out for the accumulation of personal foul penalty time will sit out the next scheduled game. Any player or coach ejected for unsporting behavior or violent conduct will sit out the next two games.
    - (b) GIRLS: Any player receiving a second yellow card is suspended from further participation in the game. She must leave the field and enter the penalty area for two minutes of elapsed playing time and no substitute may take her place during that two-minute period. Any player or coach given a red card for unsporting behavior or violent conduct will sit out two (2) games.
  - (4) **Track and Field:** after the individual has been withheld from the next scheduled contest. NOTE: All allegations of unsporting behavior must be referred to the "Jury of Appeals" for a final resolution on disqualification. A report must be submitted to the GHSA office in the event of a disqualification.
  - (5) **All Other Activities:** after the individual has been withheld from the next two (2) scheduled contests at the level at which the ejection occurred.
- (e) To satisfy the penalty of the sit-out game(s), those games must have been scheduled at the time of the ejection, and must be played to completion.
- (f) Penalties for **ejections** of a coach or player for unsporting acts shall be:
  - (1) **First Ejection:** Coach - \$250.00 fine plus penalties as per each sport's by-laws. Player: Completion of the "NFHS Sportsmanship Course" online plus penalties as per each sport's by-laws.
  - (2) **Second Ejection:** Coach - \$500.00 fine plus penalties as per each sport's by-laws; and suspension until completion of the "NFHS Sportsmanship Course" online. Player: \$200 fine plus penalties as per each sport's by-laws. NOTE: When a player, coach or team attendant has a second ejection in the same activity during a school year, that individual shall be withheld from competition for **twice** the time period of a normal suspension.

- (3) **Third Ejection: Coach** - Season suspension plus penalties as per each sport's by-laws; can not coach in any activity at any GHSA member school until successful completion of "GHSA Principles for Coaching." **Player:** Season suspension plus penalties as per each sport's by-laws.
  - (4) The Executive Director shall have the authority to levy additional penalties for repeat offenders.
  - (5) Penalties imposed by the GHSA Executive Director may be appealed as described under Section 9 of Article IV, in the GHSA Constitution.
  - (g) If the ejection occurs in the last game of a season, the penalty carries over to the first game of the next sport in which the student or coach participates (even if the ejectee transfers schools).
  - (h) When a player or coach is ejected from a pre-season scrimmage (i.e., a practice game) in any sport, the school shall be fined a minimum of \$250 and there will be no sit-out penalties imposed.
  - (i) Game Incident Reports are due within 24 hours of the contest, and are to be submitted via the GHSA electronic reporting program.
- 2.73 Any student or coach who **intentionally injures, intentionally attempts to injure, or confronts physically** another student, coach, official, spectator, or other person immediately before, during, or immediately after any GHSA-sponsored activity, may be fined (coach) or declared ineligible to participate in future GHSA activities by the GHSA Executive Director. NOTE: The notice, hearing, and appellate procedures set forth in the GHSA Constitution shall be applicable to such rulings.
- 2.74 Coaches, administrators, contest officials or players are not to make **comments in the media or on any form of social media** that are **critical of officials** and/or their calls in a game. Penalties that could be imposed by the GHSA Executive Director include fines and/or suspensions.
- 2.75 The **use of fireworks** at any GHSA-approved event shall be in strict compliance with the licensing and application procedures of Georgia law and under permit of the probate court in which the event is held.
- 2.76 **Artificial noisemakers** are allowed at outdoor events with the exception of air horns, whistles, or other similar devices that simulate the sounds of clock horns or officials' whistles. At any time that a national playing rule prohibits artificial noisemakers in a sport, that rule will supercede this by-law.
- 2.77 The officials' dressing area is "off limits" to school staff, students and spectators one hour prior to game time, during the duration of the contest, and until the contest officials depart the facility.
- 2.78 Unsporting acts committed by players or coaches will be handled as follows:
- a) If the inappropriate behavior occurs after the expiration of a contest, but while the officials still have jurisdiction as referenced in the NFHS rule book, the official may eject the player or coach and published penalties for ejections will apply.
  - b) If the inappropriate behavior occurs after the officials' jurisdiction has ended, but the official(s) witness the behavior, a Game Report shall be filed with the GHSA office and administrative penalties will be assessed against the school of the guilty parties by the Executive Director.
  - c) In the case of repeat offenders of unsporting acts, the Executive Director will be authorized to levy penalties against the school of the guilty parties regardless of whether or not an ejection has occurred.

## 2.80 - MEDIA AND FILMING REGULATIONS

- 2.81 The host or home school has the **right to determine** whether or not its **regular-season** activities may be **broadcast**, televised, webcast, taped, filmed or photographed for any "commercial" or scouting purposes.
- (a) Either school involved in the event shall have the right to video tape the event and to copy said tape, but no third party shall have that right, not even the videographer.
  - (b) A visiting school desiring to bring broadcasting personnel must obtain **permission** to do so **from the host school** prior to the date of the activity or contest.
  - (c) The host school must execute a **written contract** with the broadcast entity that complies with the GHSA rules and regulations for broadcasting.
- 2.82 The **region** has the **right to determine** whether or not **region tournament** (post regular-season) events may be broadcast, televised, webcast, tape recorded, filmed or photographed for any "commercial" purposes.
- (a) The region should set and assess any **fees** charged for broadcasting or telecasting region tournament contests or events.
  - (b) The region must execute a **written contract** with the broadcast entity that complies with the GHSA rules and regulations for broadcasting.
- 2.83 The GHSA rules and regulations for **Regular Season and Region Tournament broadcasting** are as follows:
- (a) The host school shall have the right to approve the amount of **space** used **and** the **placement** of broadcast equipment.

- (b) The host school (for regular-season events), or the region (for region tournaments) shall be entitled to all **revenue** from the sale of broadcasting rights unless the contract specifies otherwise.
- (c) **Advertising** utilized during the broadcast shall not include alcohol or tobacco products.
- (d) **Commercial announcements** shall not occur during playing time.
- (e) **Announcers** shall not criticize coaches, officials, or schools, and shall be fair and impartial in their descriptions.
- (f) The **copyright** privileges for Regular-Season events belong to and shall remain the property of the host school.
- (g) The **copyright** privileges for Region Tournament events belong to and shall remain the property of the region.

2.84 GHSB Media rules and regulations for **State Playoff events**:

- (a) Broadcast rights and **copyright** privileges to all state playoff events (i.e., after region winners have been determined) belong to the Georgia High School Association, and the GHSA has the right to determine if any of these events may be broadcast, televised, webcast, tape recorded, filmed or photographed for any purposes. NOTE: Participating schools may NOT sell tapes of state playoff events or provide copies of tapes to third parties for resale without written consent from the GHSA office.
- (b) The GHSA shall grant media access at all state playoff events to properly identified representatives of newspapers, radio stations (with broadcast contract) and television outlets ONLY. Proper identification is interpreted to mean an identification card given by the media outlet, or written documentation on the letterhead of the media outlet specifying that the bearer is working for that outlet at the GHSA event.
- (c) Any media entity wishing to broadcast or telecast (including Internet reproduction) any state playoff event must execute a written contract with the GHSA for that event. Contact the GHSA office for a contract, which shall contain specific rules and requirements.
- (d) **Advertising** utilized during a broadcast shall not include alcohol or tobacco products.
- (e) **Announcers** shall not criticize coaches, officials, or schools, and shall be fair and impartial in their descriptions.
- (f) Broadcast fees are listed in a chart that follows. The fees are "per event" except for football, basketball and soccer, which are per game. NOTE: a baseball playoff series is one event; a softball tournament is one event.
- (g) **Television and Video Webcast** rights and fees must be negotiated with the GHSA office on a case-by-case basis, except for those stations or schools having long-term contracts with the GHSA.
- (h) Video production for authorized school "coach's shows" are exempt from these rules and fees. However, schools may only tape, photograph or film events in which their team is participating.
- (i) NFHS Network is the exclusive post-season video streaming platform of the GHSA. Members of the NFHS Network School Broadcast Program (SBP) do not pay rights fees for post-season playoffs. Non-SBP schools can request to carry a playoff contest subject to GHSA rights fees & NFHS Network schedule. Request should be sent to Steve Figueroa at [stevefig@ghsa.net](mailto:stevefig@ghsa.net). For more information on joining the School Broadcast Program ([nfhsnetwork.com/sbp](http://nfhsnetwork.com/sbp)) contact Matt Abramson at [matt.abramson@playonsports.com](mailto:matt.abramson@playonsports.com).

2.85 **Radio, Audio Internet Broadcast Fees for State Playoff events**: Fees are based on the size of the market. Levels are determined as follows - Level 3 = 50,000 population and higher; Level 2 = 25,000 to 49,999; Level 1 = Under 25,000 population. Fees for each level are listed below. NOTE: These fees are for radio and audio only Internet webcasts.

| <u>Market Size</u> | <u>Football</u> | <u>Basketball</u> | <u>Baseball/Softball</u> | <u>Other Events</u> |
|--------------------|-----------------|-------------------|--------------------------|---------------------|
| Level 3            | \$225/game      | \$125/game        | \$150/event              | case by case        |
| Level 2            | \$175/game      | \$100/game        | \$100/event              | case by case        |
| Level 1            | \$125/game      | \$75/game         | \$75/event               | case by case        |

2.86 Television stations or other broadcast entities shall have the right to film portions of GHSA state playoff events in order to air selected highlights in any bona fide newscast. "Bona fide newscast" is defined as a half-hour or hour program that is regularly scheduled and includes news, weather and sports. Entertainment and commercial uses of highlights are not considered bona fide newscasts and are prohibited. Highlights may not exceed one minute per contest, or two minutes total running time in any single newscast without the consent of the GHSA. Highlights may be used, subject to the above guidelines, up to 72 hours after the event. NOTE: Members of the working press shall be allowed to use digital video cameras at GHSA state playoff events as long as such cameras are being used to obtain still images or video highlights as defined in this By-Law. Site administration shall have the authority to prevent use of such video equipment if it is determined that a video tape of a substantial portion of the event is being made.

2.87 **FLASH PHOTOGRAPHY**: Flash photography is prohibited at all indoor GHSA state playoff events unless permission is obtained from the GHSA office on a case-by-case basis. Flash photography at outdoor GHSA state playoff events is at the discretion of the onsite game officials.

- 2.88 **Parents and/or fans** connected with a member school will be allowed to use video or still cameras **from the stands** to tape or photograph GHSA state playoff events in which that member school is participating under the following conditions (EXCEPTION: One Act Play, Literary and Cheerleading restrictions remain in place):
- The cameras must be hand-held and their use cannot interfere with another fan's view of the event. Site administrators shall have the authority to halt photography if, in their opinion, this rule is being violated.
  - The tapes/photos must be for personal use only and cannot be used for scouting purposes, given to other schools for scouting purposes, used for any commercial/business purpose, or sold for profit. Violation of this rule by a member school will result in penalties from the Executive Director including a fine.
  - Anyone else filming or photographing GHSA state playoff events for any purposes must have approval of the Executive Director.

## 2.90 - REGULATIONS OF COMPETITIONS

- 2.91 **Sunday Competition:** Sunday competition is prohibited for GHSA regular season or playoff contests. Sunday practices are regulated by local school policy.
- 2.92 **Contest Rules:** All athletic and literary competitions are to be played according to the rules published by the National Federation of State High School Associations, using officially-dressed officials who are registered with the GHSA and assigned to specific member schools by the GHSA office.
- EXCEPTION: Tennis is played according to the rules of USTA, unless specified by GHSA rules.
  - EXCEPTION: Golf is played according to the rules of the USGA, unless specified by GHSA rules.
  - EXCEPTION: Riflery is conducted according to the "National Standard Three-Position Air Rifle Rules."
  - EXCEPTION: Girls Lacrosse is conducted according to the rules of US Lacrosse.
  - The National Federation prohibits the use of video tape to review an official's decision.
  - No protests are allowed in any GHSA sport or activity unless specified by NFHS rules.
  - Judgement calls by contest officials are not reviewable or reversible.
- 2.93 **Interrupted/Postponed Games:** Any GHSA competition may be interrupted due to human, mechanical, or natural causes when it is necessary to protect the safety of players and spectators. The Executive Director shall have the authority to postpone GHSA events and to direct the procedure for rescheduling when deemed necessary.
- The GHSA requires the host school to provide lightning detectors at all outdoor athletic activities.
    - When a lightning detector indicates a dangerous situation, the game manager will notify the head official. At that point, the official will suspend play and all participants and fans will go to a place of safety (NOTE: If officials spot lightning before being notified, they may suspend play).
    - The contest may resume in accordance with procedures published in the NFHS Rules Book.
  - Postponed games** are games that are terminated before they actually begin because of weather problems, emergency situations, or mechanical failures.
    - The host school should notify the opposing team and officials as early as possible when a contest is postponed.
    - The host school is responsible for determining whether an event is to be postponed until the time that game rules turn that responsibility over to game officials except when there is a written contract for that game. When there is a contract, there must be an agreement between the competing schools about the postponement.
    - School personnel will agree on the rescheduling of the contest.
  - Suspended and/or Terminated Games** - When game officials suspend a game due to weather issues, the following procedures are in place:
    - For all Baseball, Softball, Lacrosse, Soccer and JV Football contests involving teams of different classifications, there will be up to a two-hour delay (cumulative) before the contest will be terminated. (See the Baseball and Softball Sections to see the procedures involved with terminated games.)
      - If the Lacrosse, Soccer or JV Football contest is terminated before it has reached the halfway point, the contest is declared a "no contest."
      - If the Lacrosse, Soccer or JV Football contest is terminated after it has reached the halfway point, the score at the point of termination is final.
    - For Lacrosse and Soccer contests involving teams of the same classification, all contests will be played to completion. (Note: The team that is behind may choose not to resume the contest)
      - There will be no mandatory two-hour delay.
      - The 11:30 curfew will be waived.
      - Administrators from the competing schools may agree to postpone the contest and resume competition at the point of interruption at a later time.
      - The team that is behind may choose not to resume the contest at a later date.
    - All scheduled GHSA varsity football games that have been either interrupted or postponed must be played to completion. Schools must decide when completion will take place in a timely manner. The team behind in the score of an interrupted game has the option not to complete the game and the score will be recorded as it was at the point of interruption.

- (a) There will be no mandatory two-hour delay.
  - (b) The 11:30 curfew will be waived.
  - (4) Golf and Tennis procedures will be dictated by USGA and USTA rules.
  - (5) Cross Country and Track and Field will not use the two-hour delay rule.
  - (d) **Paying Officials** in shortened/postponed games:
    - (1) In the event a scheduled contest cannot be started due to weather-related conditions, officials who have arrived at the contest site will be paid one-half the contest fee in addition to the travel allowance.
    - (2) If a game is interrupted by weather or darkness before it becomes a completed game, the officials will be paid one-half the regular game fee.
    - (3) If a game is an official game at the point of interruption, the officials will be paid full fees.
    - (4) Beyond these conditions, no officials group(s) may hold the schools responsible for weather-related postponements.
- 2.94 All championship contests that end in a tie will have that tie resolved by means of the procedures that are used to resolve ties in preceding rounds of the playoffs.
- 2.95 **Absence of Officials:** In the unlikely event that game officials do not arrive for a contest, both schools should agree on one of the following procedures:
- (a) Delay the game until a new set of officials can arrive;
  - (b) Agree to play the game on another date except a Sunday;
  - (c) Use registered officials who might be in attendance at the contest;
  - (d) Use coaches or school personnel from both schools;
  - (e) Use formerly registered officials who might be in attendance at the contest.
- 2.96 **All Star Teams:**
- (a) In accordance with state law, member schools shall not permit their teams or players to participate in "Bowl" or "All Star" games during the GHSA regular season or during GHSA playoffs. Players selected to participate in out-of-season all-star games must adhere to GHSA amateur standing rules, and to NCAA regulations regarding all-star games.
  - (b) The GHSA is not involved in either sanctioning All Star games or overseeing the selection process.
  - (c) Coaches who are going to coach their own underclass players in an all-star game must report this to the GHSA. (NOTE: All provisions of by-law 1.70 concerning recruiting and undue influence remain in effect.)
- 2.97 **Admission Fees for State Playoff Contests** are set by the GHSA and are published in the various sports sections of the by-laws or on the GHSA web site.
- (a) "Babies in arms" are admitted free of charge to all events in the company of a ticket or pass holder.
  - (b) Digital tickets are available exclusively on **GoFan** (<https://gofan.co/app/school/GHSA>).
  - (c) There is no admission fee for Golf, Riflery, Literary or One Act Play.
  - (d) College and University coaches may attend GHSA playoff contests free of charge with proper ID.
- 2.98 Auxiliary personnel such as ballboys/girls or batboy/girls at all State playoff games must be at least 12 years of age.
- 2.99 All participant uniforms rules and restrictions shall be interpreted in accordance to Georgia law. The GHSA shall not enact or enforce any participant uniforms rule which prohibits religious expression of student athletes other than the rules of particular athletic events as adopted by the National Federation of State High School Associations.

## BY-LAW 3.00 - REGION

### 3.10 - REGION AUTHORITY

Each region, either through its governing board or in general session, shall have the authority to:

- 3.11 **Make rules**, which do not violate GHSA regulations, in order to successfully operate the region organization.
- 3.12 Assess mandatory membership **dues** in order to operate the region organization.
- 3.13 Set deadline **entry dates** for all region contests.
- 3.14 **Oversee** the operation of **region contests** (post regular-season) by setting:
  - (a) Sites for the contests.
  - (b) Admission fees for those contests.
  - (c) Procedures for trophies and medals.
  - (d) Contest structure for determining a region winner, including a written tie-breaker procedure.
  - (e) An appeals committee to handle appeals in region playoff competitions.

NOTE: Decisions of the Region Appeals Committee may be appealed to the Executive Director when it is believed that region by-laws have been violated.

- 3.15 Set and assess **fees** for region contest entrants to pay expenses for the contest, and to pay the expenses of region representatives to the State contest.
- 3.16 The region, not the host school, has the copyright privileges to all region tournament (post regular-season) events, and the region should set and assess any **fees** charged for broadcasting or telecasting region tournament contests or events.
- 3.17 **Pay its Secretary-Treasurer** a stipend.

### 3.20 - REGION RESPONSIBILITIES TO STATE ASSOCIATION

Each region, through its Secretary, shall:

- 3.21 **Certify the winners** in all region meets and/or tournaments to the GHSA Executive Director within the time limits specified in the By-Laws for each event.
- 3.22 Furnish a copy of complete **region results** in every region meet and/or tournament to all region schools.
- 3.23 Elect a **Region Sportsmanship Award winner** each school year using criteria developed by the region or criteria developed by the GHSA Sportsmanship Committee.

### 3.30 - REGION FINANCIAL OBLIGATIONS TO STATE ASSOCIATION

- 3.31 The host school of any tournament held within a region is obligated to **pay** five percent (5%) of the gross receipts **to the GHSA** Executive Director within ten (10) calendar days of the close of the tournament. NOTE: **Gross receipts** are defined as total income before any charges such as stadium fees, officials, etc., have been deducted.
- 3.32 Regions (or Areas) that fail to follow stated procedures or deadlines may be assessed a fine for each violation.

## BY-LAW 4.00 - STATE

### 4.10 - GHSA ADMINISTRATIVE RESPONSIBILITIES TO MEMBER SCHOOLS

- 4.11 The GHSA Executive Committee shall meet bi-annually to review By-Laws, policies and procedures of the Association, and to make additions, deletions, and modifications as necessary.
  - (a) The GHSA Executive Committee and Board of Trustees shall, from time to time, adopt whatever rules of procedure are deemed appropriate. The Chair of the meeting shall be authorized to conduct all such meetings in an orderly fashion subject to any changes in those procedures otherwise adopted by a majority vote of members present and subject to the following:
    - (1) "Pass" votes are not considered "No" votes
    - (2) Any Committee member may request a roll-call vote on any question before the Committee without the requirement of a majority vote.
    - (3) Members of the Executive Committee may propose new or amended rules, by-laws or actions to be taken or considered by the Executive Committee during the new business portion of Executive Committee meetings only if such proposal has first been submitted to the Executive Director for inclusion on the agenda for the meeting not later than five calendar (5) days prior to the date of the Executive Committee meeting. Provided however, that if the Executive Director certifies any proposal that has not been timely submitted to be of an emergency nature or to be necessary for the orderly transaction of the business or activities of the GHSA, then he shall have the authority to bring such proposal to the floor of the meeting for consideration of and action by the Executive Committee.
  - (b) The GHSA Executive Committee shall consider recommendations at its bi-annual meetings from member schools and/or region secretaries that are submitted in writing to the GHSA Office at least thirty (30) calendar days prior to the meeting.
- 4.12 The GHSA Office shall maintain an official record for all dues and fees received from any source, and shall provide for an annual audit of finances by a firm of auditors or a certified public accountant.
- 4.13 The GHSA Office shall provide all necessary forms on the GHSA web site, including the following forms from which copies are to be made to satisfy the needs of the member schools:
  - (a) Student eligibility forms.
  - (b) Declarations of intent to enter GHSA activities.
  - (c) Forms to secure sanctioning of events.

- (d) Contracts for events.
- (e) Financial statements for hosting GHSA events.

- 4.14 The GHSA Office shall provide an annual calendar that notes:
- (a) the beginning and end of the season for all activities;
  - (b) dates for Region, Area and/or State Playoff contests and/or tournaments

#### 4.20 - RECLASSIFICATION (*For the 2024-26 cycle*)

- 4.21 Every two (2) years, member schools will be assigned a "Reclassification Student Count" and placed in classifications for competition by one of the following procedures:
- (a) The Reclassification Student Count for Public schools will be based on the FTE count for students in Grades 9-12 provided by the Georgia Department of Education for the fall semester of the second year of the current reclassification cycle.
    - (1) A school will be considered a single-gender school if either gender composes less than 35% of the school population.
    - (2) A single-gender school shall have its FTE numbers doubled for the purpose of reclassification.
  - (b) The Reclassification Student Count for Private schools will be based on the actual head count of students in Grades 9-12 at member private schools as determined on October 1 of the second year of the current reclassification cycle.
  - (c) The Reclassification Student Count will be based on **projected** enrollment numbers for all schools affected by the opening of a new school, the consolidation of existing schools or the redistribution of students within a school system that must be submitted by the system Superintendent no later than October 1 of the second year of the current reclassification cycle.
    - (1) Projections must be filed for the next two school years and those numbers will be averaged to get the number by which the schools will be classified.
    - (2) In the event that a school's actual enrollment in the first semester of the new reclassification cycle exceeds the projection average by 10% or more, or an existing school exceeds the projection by 5% or more AND the additional students would have resulted in the school being in a higher classification, the school shall not be eligible for post-season play in any sport for the entirety of that reclassification cycle.
    - (3) Schools may appeal the loss of post-season competition to the Reclassification Committee and then to the full Executive Committee.
  - (d) The Reclassification Student Count or classification placement of isolated schools will be determined by the Reclassification Committee in accordance with the "Isolation Rule."
- 4.22 The Reclassification Committee may utilize the following factors in reclassification decision:
- (a) Consideration of travel time and costs, plus time out of school for students.
  - (b) Consideration of differences in the size of school populations.
  - (c) Consideration of competitive balance of the schools.
  - (d) Consideration of equitable access to playoff slots.
  - (e) Consideration of rivalries and gate-receipt issues.
- 4.23 The membership of the Association shall be divided into *six (6)* classifications as follows:
- (a) Schools will be placed in classifications (according to their Reclassification Student Count) as follows:
    - (1) *Class 6A: Largest 14% (approximately) of schools. **Note:** Schools may opt to play up into 6A.*
    - (2) *Class A Division 1 & Division 2: Smallest 26% (approximately) of schools. **Note:** Non-football playing schools will NOT be counted when calculating the schools being placed in Class A. They will be placed in appropriate regions later.*
    - (3) *The remaining schools (after 6A and Class A are populated) will be divided into four (4) approximately equal classifications (2A through 5A) with schools divided equally among the four classes at the discretion of the Reclassification Committee.*
    - (4) *When schools opt to move up in classification, only the exact number of schools at the bottom of the next class will be given the option to come down. If any of those schools opt not to come down, the GHSA office will not look further to larger schools in that class.*
    - (5) *Class A will be divided into two (2) divisions with Division 2 being comprised of the smallest approximately 50 football playing public schools. Division 1 will have the remainder of the schools.*
    - (6) *Non-public schools in Classes A, 2A and 3A will play in their assigned regions during the regular season but will then compete in a combined championship bracket of private schools only. Public schools in A-Div. 1, A-Div. 2, 2A and 3A will each have separate championship brackets. All schools in A, 2A and 3A will be seeded into playoff brackets using an evaluation format to be determined by the GHSA office.*
  - (b) **Out-Of-Zone Multiplier:** Every student attending a school from outside that school's district-assigned attendance zone shall be counted as three (3.0) students when it comes to calculating that school's



Reclassification Student Count. And that school shall be placed in the classification where the increased count falls. (Note: Schools compelled to play at a higher classification because of this stipulation may petition the Executive Director for stadium/arena seating waivers by August 31 each year. If granted, the waiver would allow that school to use the lesser seating requirements to comply with playoff by-laws.)

- (1) The designated reclassification attendance zone for all GHSA public schools shall be that attendance zone assigned to the school by its respective school district.
  - (2) *Member non-public and charter schools may select a public school's attendance zone within their county of residence that best reflects their student population to be their designated reclassification attendance zone (for reclassification purposes only, not for transfer eligibility. See Appendix S-R).*
  - (3) Children of certified professionals at the high school (grades 9-12) and military active duty dependent children will not be subject to the Out-Of-Zone Multiplier even if they live outside the school's designated attendance zone.
  - (4) *Students who entered a feeder school of a member high school in grades K-5 and remained continuously enrolled will not be subject to the Out-Of-Zone Multiplier.*
  - (5) All member schools must submit the number of students that will be counted as Out-Of-Zone students by October 15th of the final year of the reclassification cycle.
  - (6) Single-gender schools will have the Out-of-Zone Multiplier applied only to the actual number of students enrolled in the school and not to their doubled enrollment figure.
  - (7) If a school is found to be intentionally reporting incorrect numbers, that school will be banned from participating in the state playoffs for two (2) years and must pay a fine of \$2,500.
  - (8) A school shall be allowed to appeal its classification placement to the Reclassification Committee by filing a written appeal with the Executive Director not later than seven (7) days after notification of its classification placement, setting forth in detail why it contends the placement is unfair or unjustified, or why its assigned FTE number is inaccurate.
  - (9) The Reclassification Committee shall thereafter set a date for the hearing of such appeals. If the Reclassification Committee finds that the placement is unfair or unjustified, the school's placement may be modified by the Reclassification Committee. The decision of the Reclassification Committee may be appealed by the school to the Executive Committee. The Executive Committee will not consider objections from schools regarding contested classification placements unless those schools have filed timely appeals with the Reclassification Committee.
- (c) Each classification will have eight (8) regions unless otherwise determined by the Reclassification Committee or the Executive Committee.
- (d) The Reclassification Committee shall have the authority to assign a different Reclassification Student Count or classification placement for any school that is geographically isolated within its region in order to resolve difficulties in travel and time out of class. (Football may be exempted from the isolation policy.)
- (1) An individual school shall be considered to be isolated if the average distance from that school to all other schools in the region is 100 miles or more one way.
  - (2) The decision to place a school in a higher or lower classification will be based on a combination of factors that include travel distances and school population size.
  - (3) If two or three schools in a region are considered to be isolated (even if the average travel distance is less than 100 miles one way), the Reclassification Committee shall be authorized to place those schools in another classification based on travel distances and school population size.
  - (4) If four or more schools in a region are considered to be isolated (even if the average travel distance is less than 100 miles one way), the Reclassification Committee shall be authorized to form a subdivided region in which crossover games with the other subdivision will not be mandatory for region standing.
- 4.24 When the membership is divided into classifications as called for by the GHSA Constitution, the following process will be used:
- (a) Schools will be assigned a Reclassification Student Count by the GHSA office.
  - (b) Member schools will be able to review and verify their assigned Reclassification Student Count on the GHSA web site. When there is a major discrepancy between the school's count and the count determined by the GHSA staff, the school may appeal to the Executive Director to reconsider the count. The Executive Director's decision shall be final.
  - (c) When enrollment figures have been verified, schools will be placed in the proper classification and schools will have seven (7) calendar days to file a request to play at a higher classification.
    - (1) A request to move to a higher classification must be submitted over the signatures of the school's administrative authorities (i.e., the Principal and Superintendent).
    - (2) A school that transfers to a higher classification must remain in the higher classification until schools are next reclassified on a statewide basis.
  - (d) The GHSA office will initially place schools in regions and the Reclassification Committee will then meet to ratify or modify those placements. The decisions will be sent to the member schools after that meeting.
    - (1) There will be a mandatory subdivision of each region containing ten (10) or more schools by the Reclassification Committee (Exception: Cheerleading).

- (2) The Reclassification Committee may subdivide a region consisting of less than ten schools if there is an extremely large geographic area within that region.
  - (3) For football, the Reclassification Committee will require crossover games between teams in the subregions to guarantee a minimum of 70% of the season schedule unless there are isolation issues.
  - (4) For all other sports, subdivided regions must guarantee member schools a minimum number of contests within the region equal to 50% of the season schedule unless there are isolation issues.
  - (5) Any region subdivided because of geographic considerations may vote to play a full region schedule based on a two-thirds approval of all Principals in the region.
  - (e) Member schools will have seven (7) calendar days after notification of assignment to request a lateral move to another region, by filing that request with the Executive Director.
    - (1) A request to have a lateral transfer must be submitted over the signatures of the school's administrative authorities (i.e., the Principal and Superintendent).
    - (2) The request will be heard at a meeting of the Reclassification Committee and representatives from both regions shall be notified of the request, and may attend the meeting to voice their approval or state their concerns about such a move.
    - (3) A school that receives a lateral transfer must remain in that region until schools are next reclassified on a statewide basis.
    - (4) At a meeting thereafter, the Executive Committee shall hear any appeals regarding lateral transfers by the Reclassification Committee. Representatives from both regions involved in the appeal shall be notified, and may voice their approval or state their concerns about the appeal.
    - (5) Thereafter, the Executive Committee will approve, disapprove or modify the final reclassification and region alignment plan. Notwithstanding any other provision hereof, all member schools are notified that at a meeting of the State Executive Committee to finally approve reclassification, isolation status, lateral transfers, and assignment to regions, any member school may be assigned or transferred to different classifications or different regions other than those previously assigned. There shall be no further appeal of such assignment or transfer either by the member school assigned or transferred at such meeting, or by any other school which objects to such assignment or transfer. Member schools desiring to be heard on those issues are directed to be in attendance at the meeting of the State Executive Committee as all action taken in connection with reclassification and region assignment will be final and no further appeal will be allowed.
  - (f) Member schools may begin scheduling contests for the new reclassification cycle as soon as the final vote has been taken, the membership notified, and any region subdivisions finalized.
  - (g) When a majority vote is used in a subdivided region to determine scheduling and the process for selecting teams for post-season play, one or more schools may file a "minority report" with the Executive Director if the approved procedure is alleged to be unfair to all schools in the region. If the Executive Director believes that there is unfairness with the chosen procedure, the Reclassification Committee will meet and make a final decision on such matters. No further appeal will be allowed.
- 4.25 The following scheduling policy will be in effect for public schools entering the GHSA at the beginning of the second year of the reclassification cycle:
- (a) In sports where the region has two-year scheduling, the new school will not be able to play a complete region schedule at the varsity level. In those sports, the school could play a varsity non-region schedule or a JV schedule.
  - (b) In sports having year-to-year scheduling, the new school will have full membership once it has been assigned to the new region by the Reclassification Committee.
  - (c) In sports that have a region tournament to advance to post-season play, the region may allow a new school to accept a low seed in the tournament even though it did not play a complete region schedule. That is a decision made by the region.
- 4.26 Charter schools that apply for membership after the reclassification process has been completed will be accepted as schools playing sub-varsity schedules and/or non-region varsity schedules for the next reclassification cycle.

#### 4.30 - STATE ASSOCIATION CONTEST/EVENT RESPONSIBILITIES

- 4.31 The Executive Director shall determine the activities in which a **State Tournament, Playoff, and/or Meet** are to be held.
- (a) In order for a new sport to have a state competition to determine a state champion, the sport or activity must show significant growth and financial stability for a period of three (3) years.
  - (b) The GHSA Executive Director will appoint a committee and a sport liaison to monitor the sport.
  - (c) In order to have a State Championship in an Open Meet Event, there must be a minimum of thirty-two (32) teams participating and this will be determined with the "Intent to Participate" form that is submitted to the GHSA office the preceding school year (with the exception of coed cheerleading, which has a later deadline). Schools which submit this form and then withdraw from that sport will be fined.

- 4.32 The GHSA Executive Director shall determine and provide adequate **sites for all State Tournaments, Playoffs, and/or Meets** to successfully conduct the event.
- Tournament sites will not be available to participating teams for practice prior to the tournaments.
  - The GHSA shall have full rights to the use of the GHSA logo at these events, and have full and complete rights to the sale of championship merchandise at the venue. The GHSA will also have the right to display signage of corporate partners and to restrict the use of goods in the competitive area that promote a competitor of GHSA corporate partners.
- 4.33 The GHSA shall provide team **trophies** for State Champions and Runners-Up, and individual **medals** for first and second place winners in all State activities.
- The number of individual medals provided for team sports and activities is limited as follows:
 

|                     |                     |                 |                        |
|---------------------|---------------------|-----------------|------------------------|
| Baseball.....22     | Cross Country....5  | Golf.....6      | Rifle.....5            |
| Bass Fishing.....6  | Esports.....8       | Lacrosse.....27 | Tennis.....10          |
| Basketball.....18   | Football.....56     | Soccer.....27   | Volleyball.....15      |
| Cheerleading.....20 | Flag Football....25 | Softball.....24 | Wrestling (Dual)....14 |
| Game Day.....25     | Dance.....22        |                 |                        |
  - Schools may purchase additional medals if desired. The form to use to place an order for extra medals is found on the GHSA web site.
- 4.34 The GHSA shall assign field/court **officials** for all Area, Sectional, and State competitions (i.e., after the region winner has been determined), and the fees will be as shown in the chart in **Appendix F**.
- Baseball - crew of 3 or 4
  - Basketball - crew of 3
  - Cheerleading - 5 scoring judges and 2 safety judges
  - Dance - 4 scoring judges and 2 safety judges
  - Football - crew of 7
  - Game Day - 6 judges
  - Lacrosse - crew of 3
  - Soccer - crew of 4
  - Softball - crew of 3
  - Swimming (TBA)
  - Volleyball - crew of 4
  - Wrestling (TBA)
- 4.35 The Executive Director is authorized to modify all competition dates, times, sites, officiating requirements and other practical and logistical matters.
- 4.36 For state playoff events that are held at multiple, centralized sites, when venue expenses exceed 45% of the revenue for that day at that site, the GHSA will pay the excess expenses. For state playoff events hosted by member schools, the school's payment to the GHSA will be waived if the financial report for that event shows a loss, subject to GHSA review.
- 4.37 **Universal Coin Flip:** The GHSA office will conduct one "universal" coin flip prior to the Quarterfinal round and again prior to the Semifinal round in all sports to determine the designated home team in all classifications where equal-seeded teams are meeting in that round. This flip will determine whether the top or bottom of the bracket in all such cases would be the host team (subject to other hosting requirements as specified by the GHSA by-laws for each respective sport).

**4.40 - STATE PASSES TO GHSA EVENTS**

- 4.41 The GHSA shall issue **passes** for regular season and post-season events annually to:
- Elected or appointed **Board of Education members**
  - The following school system personnel **who work directly with interscholastic activities in grades 9-12:**
    - Superintendent
    - Assistant Superintendents
    - System-wide Athletic Directors and Assistant Athletic Directors
  - The following **school personnel of grades 9-12:**
    - Principal and Assistant Principal(s)
    - 1 Band Director
    - 1 Literary Coordinator
    - 1 One Act Play Coordinator
    - Athletic Director(s)
    - All athletic coaches, including **Community Coaches** who have successfully completed the GHSA Coaches Education Program and who are registered by a member school as being utilized as a high school coach.

- (7) 2 Certified Trainers employed by the school system in grades 9-12 and recommended by the Principal. A copy of their Georgia Athletic Training license must be provided. Passes for additional Certified Athletic Trainers employed by the school system may be requested.
- (d) GHSA staff members
- 4.42 **Lifetime Passes** are available to retired persons of the teaching profession, and/or those retiring from the Georgia Teaching Retirement System, who served at least twenty (20) years in GHSA member school(s), grades 9-12 as a:
- Superintendent or Assistant Superintendent AND/OR
  - Principal or Assistant Principal AND/OR
  - Athletic Director AND/OR
  - Coach of a sport listed in the GHSA by-laws.
  - A Board of Education member with at least thirty (30) years service.*
  - Retired Contest Officials with at least thirty (30) years of active service in the GHSA.*
  - GHSA staff member with 20 years or more of service.
    - Application should include the individual's permanent address and verification of years of service and must be signed off by retiring system's Superintendent.
    - Application are available under Forms on the GHSA web site.
    - Years of service to the GHSA as a Region Secretary and/or Executive Committee member shall count towards the requirements to qualify for a GHSA Lifetime Pass.

NOTE: Individuals must have retired from coaching and teaching before applying for a pass. *Should a Lifetime Pass holder return to a member school in a capacity that is eligible for a school pass, the Lifetime Pass must be revoked and placed on a "hold" status and the eligible party must request a school pass. Once the pass holder has fully retired from that school position, they may request the hold be removed and the Lifetime Pass will continue.*
- 4.43 GHSA passes are **non-transferrable** and may not be used by persons other than the individual to whom it was issued.
- The individual's name shall appear on the pass.
  - Picture Identification is required for the user of the pass at all GHSA post season events.
  - A pass that is used illegally is to be revoked and the individual to whom the pass was issued forfeits the right to receive a pass in the future.
  - The spouse of a coach, coaching in a State Playoff event shall be admitted to that event upon presentation of their spouse's pass and proper identification.
- 4.44 In the event a pass is **destroyed or lost**, the school administrator should notify the GHSA Office in writing, and should include the payment of \$25.00 with a school check to have the pass replaced.
- 4.45 When a school staff member who was issued a GHSA pass leaves the position that entitles them to that pass, the pass should be revoked **immediately**.
- 4.46 At any GHSA **regular-season** event, the host school must honor the GHSA pass that admits "the bearer and one other person" as well as similar passes from the GISA or the GAPPS (formerly GICAA). For GHSA **state playoff events**, the host school shall honor only the GHSA pass, valid media credentials and the GHSA Officials Pass.
- 4.47 School resource officers and other law enforcement personnel in uniform are to be granted free admission to all GHSA events.

#### 4.50 - CERTIFICATION OF ATHLETIC OFFICIALS

- 4.51 A plan for the **certification of athletic officials** shall be established by the GHSA office and published in the GHSA Contest Officials Handbook and Accountability Program which includes:
- published procedures for **registration** of officials
  - published guidelines for **training** officials
  - a system for **evaluating performances** of officials
  - a system of recognition of **years of service** by officials
- 4.52 The following items constitute the Athletic Officials Associations Approval Plan for the GHSA:
- The Executive Director of the GHSA shall determine the **number of officials associations** to be approved for each activity. The number of associations will be determined by:
    - The demand for officials in that activity in that geographic area of the state.
    - The number of associations already in existence in that activity in that area.
    - The extent to which member schools' needs are being met by existing associations in that activity.
    - The assignment of associations for most activities shall be the responsibility of the GHSA office.

- (5) Officials' associations must maintain minimum membership levels in order to be considered "active associations" by the GHSA in certain sports. Those numbers shall be: Baseball (20), Softball (20), Football (30), and Basketball (30).
  - (6) New officiating associations may be established when it can be demonstrated that the needs of member schools will be met by adding an association.
  - (b) The GHSA Executive Director may, at his discretion, approve **additional associations** utilizing the following criteria and procedure:
    - (1) Such associations shall make **application** to the GHSA requesting approval.
    - (2) The **By-Laws** of such an association shall be subject to the approval of the GHSA and must include provisions indicating that the association and its members will be subject to the rules and authority of the GHSA. A current copy of the association by-laws/constitution must be submitted to the GHSA office.
    - (3) An approved officials association must handle its **finances** through a central banking account, and should distribute IRS 1099 forms to all members. Every officiating association must have a Federal Tax Identification Number on file with the GHSA office.
    - (4) An approved association shall require all its **members to be registered** with the GHSA, and to comply with all requirements of the "GHSA Policies and Procedures Manual."
    - (5) All approved associations must comply with all GHSA policies, procedures and **reporting deadlines** or be subject to **fines** assessed to the association by the GHSA office.
    - (6) All chartered officiating associations must comply with the E-Verify program by July 1 of each calendar year.
    - (7) All GHSA contest officials are required to have a current "background check" on file. Background checks are valid for a five-year period. Each local association is required to keep records of the background checks. Associations assigning contest officials to GHSA sanctioned contests who have not completed this requirement are subject to a monetary fine and possible loss of charter.
  - (c) The GHSA expects every officials association to operate in a manner that does not discriminate on the basis of race, sex, color, disability, religion, national origin or age.
  - (d) Officials associations shall not charge member schools any **administrative fees** not authorized by the GHSA.
  - (e) All Invoices for officiating fees in all sports shall be paid within 14 days of receipt of the invoice. Failure to do so will result in a 10% late fee being charged to the member school by the assigned local officiating association. Local associations may send invoices for game fees as agreed upon with the member school. NOTE: Member schools are prohibited from paying contest officials at the game site.
  - (f) Officials may register with only one (1) local association per sport during a school year, and officials are not allowed to officiate GHSA events until the registration process has been completed with the GHSA office.
  - (g) In the event that a local association does not have a sufficient number of eligible officials to work on a specific day/night, officials may be requested from other GHSA-chartered associations. It is the responsibility of the local association assignor in need of additional officials to make the initial contact with the assignor of another association to work out details of the request.
  - (h) All GHSA chartered associations and registered contest officials shall comply with the policies and standards referenced in the "GHSA Contest Officials Handbook and Accountability Program."
  - (i) Officials shall not be assigned in any GHSA sport or activity if they have had any connection in the past 10 years (attended, worked in the system, have children or other relatives in the system, etc.) with the schools they are officiating or judging.
  - (j) All GHSA contest officials shall adhere to the "Uniform Standards" as listed in the "GHSA Contest Officials Handbook and Accountability Program."
- 4.53 Contest officials and officials' associations are independent contractors and not employees of the GHSA or its member schools.
- 4.54 In the event that officials do not show for a scheduled event without notification or emergency situation, a fine shall be assessed to the officials association for twice the amount of the game fees and that amount be divided between the competing schools.
- 4.55 All decisions of the GHSA Executive Director in regards to officials shall be subject to the **appellate procedures** as set forth in the GHSA Constitution.
- 4.56 **Universal contest fees** shall be charged for all scheduled, regular-season interscholastic contests (including scrimmages). The universal fee schedule shall be as shown in the chart in **Appendix F**. Schools and officiating associations may not reduce or increase game fees from those listed in this section. Penalties may be imposed for those violating this rule.
- 4.57 Current-year registered contest officials have the option to purchase a "GHSA Officials *Pass*" through their local association via the registration process with the GHSA office. If this option is selected, an additional

\$15.00 will be added to the annual GHSA registration fee. The "GHSA Officials *Pass*" will allow the legal bearer of the *pass* his/her admission *plus one (1)* to all GHSA sanctioned events/activities.

#### 4.60 - SPECIAL GHSA POLICIES

- 4.61 **Gender Equity:** The Georgia High School Association shall comply with the requirements of subsections (a) through (f) of Code Section 20-2-314, as those requirements relate to the association's functions of organizing, sanctioning, scheduling, or rule making for events in which public high schools participate. The Georgia High School Association shall, no later than October 1, 2003, and every year thereafter, submit a report to the General Assembly regarding its compliance with paragraph (1) of this subsection. Such report shall address the number, type, and disposition of written requests for the association to organize and administer regional or state events for additional or different sports; written requests for information regarding the types of athletic events for public high school students that the association organizes and administers; and written inquiries and complaints received by the association with respect to gender discrimination in connection with public high school events. The report shall address all such written requests, inquiries, and complaints, regardless of whether such request, inquiry, or complaint is made by letter, e-mail, memorandum, or any other form of written communication. Each report shall cover the time period beginning on July 1 of the previous year and ending on June 30 of the year in which the report is due. In addition, the association shall have in effect a policy requiring notification to persons who make such requests, inquiries, or complaints verbally that such request, inquiry, or complaint will not be included in the association's reporting to the General Assembly regarding compliance with this Code section unless such request, inquiry, or complaint is made in writing.
- 4.62 **Open Meeting/Open Records:** The Georgia High School Association shall comply with the requirements of Article 4 of Chapter 18 of Title 50, relating to the inspection of public records, and Chapter 14 of Title 50, relating to open and public meetings, to the extent that such records and meetings relate to the association's activities with respect to public high schools; provided, however, that such association shall not be required to comply with such statutes or to conduct open and public meetings or provide inspection of records where the sole subject of such meeting or record pertains to the academic records or performance of an individual student or the eligibility of an individual student to participate or to continue to participate in sponsored events or contests based on academics; provided. However, where a meeting or record of such association is devoted in part to matters excepted in the preceding proviso, any portion of the meeting or record not subject to such exception shall be open to the public.
- 4.63 **Steroids/Performance Enhancing Drugs:** The Georgia High School Association strongly opposes the use of anabolic steroids and other performance enhancing substances by high school student-athletes. The GHSA believes that such usage violates legal, ethical and competitive-equity standards and imposes unreasonable long-term health risks on the user. The GHSA encourages member schools to educate students and coaches about the perils of steroid usage, and the GHSA will distribute educational materials about this issue to member schools.
- 4.64 **Penalties for Violations:** In accordance with the GHSA Constitution, the Executive Director is empowered to make a determination as to whether a violation of GHSA rules has occurred, and to assess the appropriate penalty which may include a fine and/or probation. A non-exhaustive list of violations and fines is published in **Appendix P** of the Constitution & By-Laws.
- 4.65 **Indemnification:** The GHSA shall, to the extent legally permissible, indemnify each person who may serve or who has served at any time as an officer, committee member, employee or volunteer of the GHSA against all expenses and liabilities, including, without limitation, counsel fees, judgments, fines, excise taxes, penalties and settlement payments, reasonably incurred by or imposed upon such person in connection with any threatened, pending or completed action, suit or proceeding in which he or she may become involved by reason of his or her service in such capacity; provided that no indemnification shall be provided for any such person with respect to any matter as to which he or she shall have been finally adjudicated in any proceeding not to have acted in good faith in the reasonable belief that such action was in the best interests of the GHSA; and further provided that any compromise or settlement payment, other than those funded by insurance, shall be approved by a majority vote of a quorum of GHSA Executive Committee who are not at that time parties to the proceeding. The GHSA may maintain insurance, at its expense, to protect any such person against any such liability, cost or expense.
- 4.66 **Executive Oversight Committee:** (A) *There is hereby established an Executive Oversight Committee comprised of ten (10) members as follows:*
- (1) *One member to be appointed by the Governor;*
  - (2) *One member to be appointed by the Lieutenant Governor;*

- (3) *One member to be appointed by Speaker of the House of Representatives;*
  - (4) *Two members to be appointed by the Georgia School Superintendents Association, with one such member representing approximately one-half of the Georgia High School Association members with classifications based on lower student enrollment figures and the other such member representing approximately one-half of the members with classifications based on higher student enrollment figures;*
  - (5) *One member to be appointed by the Georgia School Boards Association;*
  - (6) *One member to be appointed by a state-wide association of high school athletic coaches with a current membership of not less than 300 Georgia residents and which is recognized by a majority of the Executive Oversight Committee;*
  - (7) *One member to be appointed by a state-wide association of high school athletic officials, referees, and umpires with a current membership of not less than 300 Georgia residents and which is recognized by a majority of the Executive Oversight Committee;*
  - (8) *Two members to be appointed by the governing body of the Georgia High School Association, with one such member representing approximately one-half of the member schools based on lower student enrollment figures and the other such member representing member schools based on higher student enrollment figures;*
- (B) *A quorum of the Executive Oversight Committee shall consist of six (6) members.*
- (C) *The Executive Oversight Committee shall elect a chairperson and vice chairperson from among its members.*
- (D) *Members of the Executive Oversight Committee shall serve terms of three (3) years (except for the initial terms set forth below) and are eligible to succeed themselves only once. In order to establish a rotation of terms to ensure that a majority of the members' terms do not expire concurrently, the members of the Executive Oversight Committee set forth above in paragraph (A)(1),(2) and (3) shall serve an initial term of one (1) year; the members set forth in paragraph (A) (4), (5) and (6) shall serve an initial term of two (2) years; and the members set forth in paragraph (A) (7) and (8) shall serve initial terms of three (3) years. Thereafter, members of the Executive Oversight Committee shall serve terms of three (3) years. In the event of a vacancy in any seat, the appointing officer or body shall be authorized to appoint a replacement member for the remainder of the term.*
- (E) *The authority and duties of the Executive Oversight Committee shall include:*
- (1) *To meet in person or remotely not less than twice each school year;*
  - (2) *To meet in person or remotely upon the call of the chairperson or a majority of the Executive Oversight Committee;*
  - (3) *To establish policies and procedures for the Executive Oversight Committee;*
  - (4) *To conduct any independent audit, review or investigation the Executive Oversight Committee deems necessary, including, but not limited to, the audit, review, or investigation of the classifications of participating schools and travel-related issues of participating schools;*
  - (5) *To conduct an annual evaluation of the Georgia High School Association as a whole and present a report of its findings, recommendations, and conclusions to the General Assembly's High School Athletics Overview Committee.*
- (F) *Travel and other expenses actually incurred by the Executive Oversight Committee, or any member thereof in the performance of his or her duties, shall be reimbursed by the Georgia High School Association.*

# ATHLETICS

(NOTE: State Playoff Brackets for ALL sports can be found in Appendix B at the end of this publication)

## SECTION 1 BASEBALL

### GENERAL INFORMATION:

- A. Baseball is a state championship event in each classification, and schools are aligned on a regional basis.
- B. All games will be played by the rules published by the National Federation of State High School Associations (NFHS).
- C. The maximum number of **games** allowed (not including state playoffs) is thirty (30). This limit of 30 games includes any region tournament games. Beginning and ending dates for practice and competition can be found at the front of this publication.
- D. A school shall not allow its baseball team to engage in an interscholastic practice and/or scrimmage game, except for one (1) interscholastic scrimmage consisting of a 7-inning game using a “free substitution” format and umpires registered with the GHSA.
- E. All varsity baseball games shall be played with officially-dressed officials who are registered under the GHSA plan for the registration of officials.
  - 1. The assignment of officials for regular-season games, invitational tournaments, and any sub-region or region playoffs allowed in the 30-game limit will be made by the GHSA office.
    - (a) The GHSA will assign one or more associations to each school for their games.
    - (b) The school and the local association(s) will sign a contract for the games that are assigned.
  - 2. In accordance with By-Law 2.71-c, the host school has the responsibility of providing security escorts for umpires at all regular-season and post-season games.
- F. The following items allowed in the NFHS rule book as “State Adoptions” have been adopted by the GHSA:
  - 1. A game will end anytime that a team is 10 or more runs behind and has completed five or more turns at bat. A game will end anytime that a team is 15 or more runs behind and has completed three or more turns at bat.
  - 2. The suspended game rule will be used:
    - (a) When a game is stopped before it becomes a legal game (4.5 or 5 innings), it is considered “no contest” and any replay will begin from the first inning.
    - (b) When a game is stopped after it becomes a legal game and a winner can be determined, it is a completed game.
    - (c) When a game is stopped after it becomes a legal game and a winner can not be determined, any replay will begin from the point of interruption.
    - (d) In any terminated game, accumulated pitches will count.
  - 3. The use of the “courtesy runner” is the only “speed-up rule” that has been adopted. Being a courtesy runner does not count as a game played.
  - 4. Sub-varsity teams have the option of using free substitution and a batting order of ten (10) players if agreed upon by both coaches before the game. Lineup cards must be presented to the umpire at the plate meeting and the batting order shall remain the same throughout the game.
- G. The following interpretations have been approved by the GHSA.
  - 1. Termination of the game due to weather, unplayable conditions, or mechanical malfunctions:
    - (a) The umpires may halt play for up to two hours when conditions do not allow play to continue.
      - (1) The two-hour interruption(s) is cumulative
      - (2) The game must be terminated when the two-hour time has elapsed. If the first game of a doubleheader is terminated, the second game will be postponed.
      - (3) The two-hour period does not include time needed to prepare the field for the resumption of play.
    - (b) Umpires must wait for at least thirty (30) minutes before terminating a game for unplayable field conditions.
  - 2. **Pitching restrictions:**
    - (a) **Regular Season Maximum Pitches in One Day:** Varsity 110; sub-varsity 90.
    - (b) **Regular Season Required Rest Periods:**

| <u>Varsity</u> |        | <u>Sub-Varsity</u> |        |
|----------------|--------|--------------------|--------|
| 1-40 Pitches   | 0 Days | 1-30 Pitches       | 0 Days |
| 41-60 Pitches  | 1 Day  | 31-44 Pitches      | 1 Day  |
| 61-85 Pitches  | 2 Days | 45-64 Pitches      | 2 Days |
| 86-110 Pitches | 3 Days | 65-90 Pitches      | 3 Days |



**NOTE:** During the Regular Season, a pitcher shall not throw more than 110 pitches (90 for sub-varsity) cumulative over a two-day period and cannot pitch more than two consecutive days. The rest period is based on the total pitches thrown during a given two-day period. Pitches thrown during a game that was suspended or rained out shall be counted towards any pitching restriction thresholds.

- (c) **State Tournament** - During the State Tournament, no pitcher shall be allowed to throw more than **120 pitches over a three-game series**. The "Required Rest Period" chart does not apply.
  - (d) A pitcher at any level (varsity or sub-varsity) shall be allowed to finish the batter when the maximum pitch count limit is reached during an at-bat, but must be replaced immediately when that at-bat ends.
  - (e) A "Day of Rest" is defined as a calendar day. Example: a varsity level pitcher who reaches the 110-pitch limit on a Tuesday would not be allowed to pitch again until Saturday.
  - (f) Tabulation of Pitch Counts - It will be the responsibility of each team to track their own pitch counts throughout the game. And at the conclusion of the game, the head coaches shall meet to approve and agree upon the respective pitch counts for each team. It will then be the responsibility of the home team head coach to enter the agreed-upon numbers into the "PitchKount" electronic tabulation program.
  - (g) In games versus non-GHSA member schools, the GHSA pitching restrictions shall be adhered to, regardless of the pitch count policy of the host school affiliation or state association. When playing out of state, it is the GHSA member school's responsibility to report the pitch count information in PitchKount.
  - (h) If a school is found to have violated any of the provisions of this policy, the offending school shall be fined \$250.00 and the head coach at that level assessed a two-game suspension, and the game forfeited. Any subsequent violation during the same season will result in penalties being doubled and the head coach being required to meet with the Executive Director prior to being reinstated to coach.
- H. *The use of WBGT for ALL Contests is mandated as follows:*
1. *WBGT must be measured 15 minutes prior to start of contest, coaches and umpires must be notified.*
  2. *If WBGT is equal or above 86.0 F, an ice immersion tub must be present and ready for use.*
  3. *If WBGT is equal or above 88.0 F, Umpires will take a 3-minute hydration break at the beginning and mid-point of inning 3 and continuing until the conclusion of the game.*
- I. Contracts are required for all regular-season and playoff contests. Contracted games can not be canceled for any reason other than weather/playing conditions without the approval of the GHSA office. **NOTE:** When rescheduling, region games take priority.
- J. Schools must enter team schedules, rosters and weekly game/meet results during the season on MaxPreps and be responsible for updates as needed. This information will support statewide media, event programs, broadcasts partners and GHSA Region Standings. Teams are encouraged to maintain team/individual statistics on MaxPreps.

#### STATE PLAYOFFS:

- A. Four teams from each region will advance to the state playoffs. Regions must determine their four winners within the 30-game playing limit.
- B. When a region does not have a tie-breaker method in place, the following procedure will be used for seeding purposes:
  1. Percentage of head-to-head wins against tied teams
  2. Least number of runs allowed between tied teams
  3. Least number of runs allowed in overall region play
  4. Mini-game of five (5) innings
  5. In any step of the tie-breaking process if a tie involving more than two teams is broken so that all ties are broken, that step determines the placements. If two teams remain tied after a step is completed, revert back to head-to-head record to break the tie. If the tie cannot be broken, move to the next step.
- C. All rounds of the state playoff involve a best two-of-three series.
  1. The higher seeded team, or the team designated as the host team by the Universal Coin Flip (if the teams are equal seeds), will host all three games.
  2. A doubleheader is required on the first day of each round of the playoff series.
  3. The host team will be the home team in the first game, and the visiting team will be the home team in the second game. The higher-seeded team will be the home team for a third game, or a coin flip will determine home team if both teams are equal seeds.
  4. The responsibilities of the host team are to:
    - (a) furnish game balls beyond those furnished by the GHSA
    - (b) notify the GHSA office as to the arrangements for the series
  5. In the event that two schools involved can not agree on the arrangements for the series (dates, times, etc.), the GHSA Executive Director will make a ruling to cover the situation.

6. In the event that a State Playoff game is suspended prior to becoming a legal game, or if it is suspended after becoming a legal game without a winner being able to be determined, it shall resume from the point of interruption on the next available date. If that date can not be agreed upon by the competing schools, the GHSA Executive Director shall determine the playing date. If a State Playoff game is suspended at a point where a winner can be determined, it shall be considered an official game.
- D. The play windows for the State Tournament are listed in the Beginning and Ending Dates published at the beginning of the Constitution. In all cases, the first date of the play window will be a doubleheader, followed by the "if" game on the second date.
- E. The finances for the **state playoffs** are as follows:
1. Admission fees **must** be charged for all post-season games: \$10 for doubleheaders and \$7 for single games.
  2. Total gate receipts include all ticket sales and radio/television payments (see fees in Broadcast section 2.80).
    - (a) The fee for a radio broadcast is paid to the host school prior to the game and is added into the gate receipts.
    - (b) Television contracts are negotiated by the GHSA Executive Director.
    - (c) Money from concessions and program sales are not part of the gate receipts.
  3. The process of dealing with finances is handled as follows:
    - (a) Twelve percent (12%) of the gross receipts will be paid to the GHSA.
    - (b) The umpires will be paid out of gross receipts.

NOTE: If the gross receipts are not sufficient to pay the umpires, the host school will pay that cost.
    - (c) The remaining balance is to be divided with 50% of the proceeds going to the visiting team and 50% to the host team.
      - (1) The visiting team shall be paid \$.80 per mile (one way) for travel.
      - (2) The host team is responsible for paying local service charges, stadium charges, operating expenses, personnel costs, etc., out of their 50% share.
      - (3) Admission fee for **State Championship Series** at a neutral site will be posted on the GHSA web site.
  4. At neutral-site games, each participating team is allowed free admission for a maximum of 25 players and team essential personnel. Coaches will be admitted with a GHSA coaching pass.

## SECTION 2 BASKETBALL

### GENERAL INFORMATION:

- A. Basketball is a state championship event in each classification for boys and girls, and schools are aligned on a regional basis. Beginning and ending dates for practice and competition can be found at the front of this publication.
- B. All basketball games will be played by the rules published by the National Federation of State High School Associations.
- C. The number of basketball games allowed (not including regional, sectional and state tournaments) is twenty-five (25) regular season games either in head-to-head competition or in invitational tournaments that have been approved by the GHSA. NOTE: All basketball schedules and contracts are to be completed by June 1 each year.
- D. The following policies exist for basketball games:
  1. Warm-up time between games shall be no less than fifteen (15) minutes. The game clock operator shall start the clock between games when the last player from the previous game leaves the court.
  2. Sub-varsity games shall be played using seven (7) minute quarters. Playing time may be reduced on a night that precedes a school day.
  3. Region and State Tournament games do not have a starting time restriction, but shall be completed no later than 11:30 p.m., on a night that precedes a school day.
- E. In accordance with National Federation rule options, when there is a competitive imbalance between teams, the second half of a game may be reduced to six (6) minute quarters, while using normal timing/scoring rules when:
  - (a) The point differential at halftime is thirty (30) points or greater, and the coach of the trailing team wishes to have the quarters reduced.
  - (b) The point differential at the beginning of the fourth (4th) quarter is thirty (30) points or greater, the reduction will be invoked automatically.
- F. All varsity basketball games shall be played with officially-dressed basketball officials who are registered under the GHSA plan for the registration of officials.
  1. The assignment of officials associations for regular-season games, invitational tournaments, and sub-region and region tournaments will be made by the GHSA office.
    - (a) The GHSA will assign one or more associations to each school for their games.

- (b) The school and the local association(s) will sign a contract for the games that are assigned.
  2. The host school must provide an adult (21 years old or older) to maintain the official scorebook, electronic scoreboard, and 35-second clock at all varsity games.
  3. The host school must provide a safe and secure changing area near the playing court for contest officials, free from traffic by school staff, students and spectators one hour prior to game time, during the duration of the contest(s) and until the contest officials depart the facility.
  4. In accordance with By-Law 2.71-c, the host school has the responsibility for providing security escorts for officials at all regular season games and tournaments.
  5. The host school for a "special event" contest shall contact the GHSA office for the officiating assignments.
  6. All varsity level games shall be officiated by a 3-person crew. Sub-varsity games may be officiated by a 2-person crew.
  7. **35-SECOND CLOCK** – The 35-second clock is to be used in all "Varsity Level" games.
    - (a) The individual designated as the "Shot Clock Operator" shall be approved through the GHSA 35-Second Shot Clock Operator certification.
    - (b) Schools not in compliance with the 35-second shot clock requirements will be assessed a technical foul to start each game.
- G. Schools must enter team schedules, rosters and weekly game/meet results during the season on MaxPreps and be responsible for updates as needed. This information will support statewide media, event programs, broadcasts partners and GHSA Region Standings. Teams are encouraged to maintain team/individual statistics on MaxPreps.
- H. *Spectators from participating schools shall not be allowed to sit or stand in the first row of seating at court level on either sideline or endline, and a minimum of one (1) school administrator must be in close proximity to the student section.*
- H. **MISCELLANEOUS INFORMATION:**
1. Cheerleaders at basketball games shall be restricted from the area at the end of the court during the time a game is in progress unless they are more than eight (8) feet from the boundary line of the court.
    - (a) This includes when cheerleaders are in an "L" shape with part on the sideline and part on the endline.
    - (b) The host school or tournament director is responsible for enforcing this rule.
  2. The throwing of souvenirs (such as small basketballs, t-shirts, etc.) into the stands is prohibited until after the final basketball game of the day.
  3. During **Semifinals and Finals**, schools are limited to a maximum of 20 uniformed cheerleaders at court side.
    - (a) Cheerleaders shall not occupy spectator seating and shall be in designated courtside areas.
    - (b) Mascots shall be members of the student body.
  4. No artificial noisemakers (including megaphones) shall be allowed in the gym during basketball games.
  5. Bands shall play only during intervals between periods or during timeouts; the home school is responsible for enforcing this rule.
  6. The practice of cutting or removing nets, or hanging on the rim or backboard is prohibited at all GHSA games.
  7. For the pregame and second half warmup period and during the time of team introductions, teams can not run around or through the opposing team's half of the court and the midcourt circle area is off limits to both teams. The penalty for violation of this rule will be a technical foul if the officials have taken jurisdiction of the game.
  8. All spectators must wear shirts during the games.
  9. The host school should provide dressing areas for visiting teams in close proximity to the playing floor. Game managers, in conjunction with game officials, may extend halftime intermission to 15 minutes if the dressing area is not in close proximity to the playing floor.
  10. Coaching boxes must be marked on the floor in both bench areas with one line that is 28 feet from the end line of the court.
  11. An "X" must be marked on the floor in front of the spot where the scorekeeper sits in order to facilitate the substitution process.
  12. Players are prohibited from warming up on the court at halftime intermission of the preceding game.
  13. In accordance with NFHS rules, the official scorer is required to wear a black-and-white, vertically-striped shirt.
  14. There shall be a minimum warm-up time of 15 minutes between multiple games.

#### **REGION TOURNAMENTS:**

- A. Each region will decide its method for determining the teams that will advance to the State Tournament.
1. Four teams from each region will advance to the First Round of the State Tournament in all classifications (boys and girls), even when the region is sub-divided.
  2. No region may use a double-elimination tournament.
  3. The tournament committee or tournament director shall secure the services of competent scorekeeper(s) and clock operator(s). NOTE: No team shall have the privilege of placing its scorekeeper and/or timekeeper at or near the position of the official scorekeeper and clock operator.

- B. Officials associations for sub-region and region tournaments will be assigned by the host school's local association. Issues for covering the tournament will be handled by the tournament director and the assigning officer of the selected officials association.
- C. Region post-season games (sub-region games and full region games) must have a minimum of two games at each site.

## STATE TOURNAMENT

- A. In the **First Round through the Quarterfinal Round**, the higher-seeded teams will host (if equal seeds meet, a "universal" coin flip will determine the host school). In each of the first three rounds, there are two dates of competition.
  - 1. The girls teams will play on the first night of the designated round, while the boys teams will play on the second night of the round.
  - 2. In the event that the same school hosts both the boys and girls games, the host school may petition to schedule a doubleheader with the following stipulations:
    - (a) If a doubleheader is scheduled, it shall be played on the second playing date of that round. If more than two (2) schools are involved, **they must all agree** on the play date or the schools will play on the gender-designated dates and there will not be a doubleheader.
    - (b) If the day of the doubleheader is requested to be changed, **all participating schools must agree** to play the doubleheader on the requested date.
  - 3. Officials will be assigned by the GHSA office. Officials may not work back-to-back games in the post-season except in emergency situations.
  - 4. The host team will provide an adult (21 years or older) timer and scorer.
  - 5. All other GHSA by-laws pertaining to the State Tournament apply to these games except where specified.
  - 6. **SEATING:**
    - (a) All seats are to be general admission, and tickets will be full-price for each day of the tournament.
    - (b) The host school shall provide 50% of the available seating to spectators from the visiting school(s).
    - (c) The **minimum seating requirements** are: 7A, 6A & 5A - 1,200; 4A - 1,000; 3A & 2A - 700; A - 500 (with bleachers on both sides).
  - 7. **FINANCES:**
    - (a) Admission fee for the **First Round through the Quarterfinal Round** is \$7.00 for single games and \$10.00 for doubleheaders. Admission fee for the **Semifinal and Final Rounds** is \$15.00.
    - (b) Only GHSA passes and valid press credentials, with a picture ID, will be honored for admission.
    - (c) In the **First Round through the Quarterfinal Round:**
      - (1) The host school will be allowed to deduct expenses up to \$500.00 for a single game or \$700.00 for a doubleheader.
      - (2) The host school will deduct officials fees of \$555.00 for a single game or \$1110.00 for a doubleheader.
      - (3) Visiting team(s) will be paid \$.80 per mile (one way).
      - (4) For a single game or a doubleheader involving two schools, the net proceeds are split equally between the two schools and the GHSA.
      - (5) For a doubleheader involving three schools, the net proceeds will be divided as follows: 20 percent to the GHSA; 20 percent to each visiting team and 40 percent to the host school.
    - (d) In the **Semifinals and Finals**, from net receipts (after all expenses have been paid), the GHSA will receive 40%, and 60% is divided among the participating schools.
  - 8. **Semifinal Round** games will be played at centralized sites (to be determined).
  - 9. The **Final Round** games will be played at a centralized site(s), to be determined, and will be known as the "Dr. Ralph Swearngin Basketball Championships." Dates for the semifinals and finals may be found in the Beginning and Ending Dates table at the front of this publication.
- B. Until eliminated from the tournament of its respective classification, each team will be entitled to free admission at their site on the date of their game only:
  - 1. A maximum of twenty (20) players and team essential personnel.
  - 2. A maximum of sixteen (16) cheerleaders in uniform.
  - 3. Coaches will be admitted with a GHSA coaching pass.
  - 4. The school will be charged by the GHSA office for additional personnel entering at the team gate.
  - 5. Floor passes will be given to the basketball coaches listed on the official roster and a maximum of six auxiliary personnel (managers, statisticians, and trainers).
  - 6. Team Instructions for State Tournament games will be available on the GHSA web site.
- C. In the **First Round through the Quarterfinal Round**, the **host team** is designated as the home team and will wear **white jerseys**. In the **Semifinal and Final Rounds**, the team listed at the **bottom of the bracket** is designated as the home team, and will wear **white jerseys**, regardless of the seeding in prior rounds.

- D. Upon arriving at the tournament site, the head coach or a designee shall:
1. submit a complete lineup to the official scorer.
  2. verify with the opposing coach the color of jerseys being worn.
- E. Tournament sites will not be available to participating teams prior to the tournament. **EXCEPTION:** When the team of the host school is in the tournament.
1. Teams playing in the first game of the day shall have access to the court no earlier than thirty (30) minutes before game time.
  2. There will be a minimum of fifteen (15) minutes between tournament games.
- F. Each team is responsible for providing its own basketballs for warm-ups, towels, training supplies, and half-time refreshments, unless notified differently by the GHSA office. The GHSA will provide game balls at the **Semifinal** and **Final** Rounds.
- G. Each school is responsible for the behavior of its coaches, players, and spectators at tournament games. Therefore, the behavior of these groups must be monitored by school administrators, especially (but not exclusively) in the following areas:
1. No artificial noise makers, banners or signs, radios or similar music-producing devices are allowed.
  2. Throwing objects on the floor will not be tolerated.
  3. Cutting nets, hanging on rims, climbing on backboards is prohibited.
  4. Security personnel may ask that spectators refrain from standing the entire game if it blocks the view of other spectators who choose not to stand.
  5. Displays of unsportsmanlike conduct directed toward the opposing team or the officials will not be tolerated.
  6. Spectators are not allowed on the court at any time prior to, during or following the game. Players are not allowed to go into the spectators' area following the game.
  7. Pep bands with a maximum of 15 members and one (1) adult school personnel member may be allowed. If the home team allows its pep band to attend, it shall also allow the visiting school's pep band to attend.
- H. Each school in the tournament is allowed to have one video camera filming only its games under the following conditions:
1. The video personnel of the school must film from an area designated by the Tournament Director.
  2. The video of the tournament game(s) may not be shown at the school or in the community for admission, nor on cable television (see regulations in Broadcast section 2.80) without authorization from the GHSA.
- I. Tournament Officials
1. Officials for State Tournament play will be selected using the following criteria:
    - a. District partnership rankings.
    - b. Evaluation reports from regular season games.
    - c. Nominations from members of the Evaluation Committee.
    - d. Evaluations from previous State Tournament games.
  2. There will be three (3) officials on the court in all State Tournament games.
  3. Official scorekeepers for the Championship Finals will be selected by the GHSA office from a list compiled from recommendations by Region Secretaries.

### **SECTION 3 BASS FISHING**

#### **GENERAL INFORMATION:**

- A. Bass Fishing is a state championship co-ed event open to all GHSA schools in all classifications.
- B. Notification of entry in Bass Fishing must be filed with the GHSA office by March 1 for the next school year.
- C. The Bass Fishing State Championship will be held in the Spring of each year. The first of four regional qualifier will begin in January of each year.
- D. The GHSA is partnering with MLF/TBF to oversee and manage the Regional Qualifiers and State Championship Fishing Tournament.
- E. Sites for Competition- the GHSA/MLF/TBF shall make the determination of the region competition sites. Schools interested in hosting may submit a request.
- F. There is no limit to the number of students each school can have on their team roster.

- G. Each school may enter up to six boats in each regional competition. Schools can enter boats into multiple GHSA regional competitions.
- H. The top 15 boats from each regional advance to the state championship. One additional boat will advance from each regional for every 10 boats that compete over a minimum of 100 boats in the regional. Boats will advance to the state championship from the first event in which they qualified. If a boat has already qualified for the state championship, the next eligible boat will advance.
- I. There is no limit of State Championship qualifiers from a member school.
- J. Each boat may have up to four student contestants, only two of which may be in the boat at any one time, assigned from the team's roster.
- K. No student may be assigned to more than one boat.

#### ELIGIBILITY TO ENTER COMPETITION PLAY AND SUBSTITUTIONS:

- A. All participating students must be submitted for eligibility through the GHSA office. Each school shall enter all GHSA eligible students on the electronic roster. This roster may be revised throughout the regular season and shall serve all roster purposes in these rules.
- B. All member schools participating must abide by the GHSA policy requiring the HEAD COACH to be a certified employee. All Volunteers and Boat Captains are not required to be certified employees.
- C. For more rules, policies, and registration information, please go to [ghsa.net/bass-fishing](http://ghsa.net/bass-fishing).

### SECTION 4 CHEERLEADING

#### GENERAL INFORMATION - SUPPORT/SPIRIT AND COMPETITIVE:

- A. Schools may have only one (1) varsity competitive team. Schools may choose to have any number of support/spirit squad(s) that do(es) not compete.
- B. All cheerleaders (competitive and non-competitive) must be eligible according to academic standards and the transfer rule and must be declared eligible by the GHSA office on the proper eligibility forms. Non-students are not allowed to be part of a sideline cheerleading group either as mascot or "junior cheerleader."
- C. All cheerleaders (competitive and non-competitive) must have a physical examination on file in the school office before they may try out, practice, or perform.
- D. All cheer coaches (competitive and non-competitive) must complete a GHSA Rules Clinic or the school will be fined.
- E. At basketball games, support/spirit squads may perform stunts and/or tumbling that are allowed by NFHS Spirit rules without mats. NOTE: National Federation rules dealing with safety are to be followed in any cheerleading practice or performance.
- F. No "**stomping**" of any kind is allowed in the stands or seating area of the gymnasium. Stomping is restricted to the floor of the gymnasium.
- G. **Taunting** of any kind will not be tolerated. **Aggressive cheers** should not be performed under any circumstances.
- H. **Cheerleading apparel** is restricted as follows:
  1. Male uniform for competition cheerleading will be uniform pants and a top which counterparts those worn by the female teammates. Sideline male cheerleaders may include shorts in place of the pants. Tank tops will not be permitted.
  2. Female cheerleaders (sideline & competition) must wear a uniform (skirt or dress) that fully covers the athlete's entire torso. The skirt or dress should cover the briefs, bloomers or any spandex material. *Bows should be in school colors.*
  3. All athletes on the same team must wear the same uniform when performing at a game or competition. *Hair must be secured and must NOT extend below the waist.*

### I. MISCELLANEOUS INFORMATION:

1. Beginning and ending dates for practice and competition can be found at the front of this publication.
2. Cheerleading teams are allowed to attend camps after the last day of school until July 31st.
3. Spirit Cheerleading season ends after the last day of school.
4. Out-of-season practices may be held in preparation for tryouts only. Once tryouts are complete, no practices may be held until school is out. Practices for tryouts are limited to a maximum of ten (10) consecutive school days per school between February 1 and the last day students are in school. (NOTE: All a school's different level teams must use the same 10-day period.)
5. Eligibility for try-outs:
  - (a) Students must be enrolled at a school in order to try out for that school's cheerleading team. A student may be enrolled in only one school at a time. EXCEPTION: See By-Law #1.45 (g)
  - (b) Enrolled migrant students may try out for a cheerleading team, but may not represent the school at the varsity level during the school year until the migratory sit-out period has ended.
  - (c) Students must meet academic eligibility requirements in order to try out.

### COMPETITION RULES:

- A. Cheerleading is a state championship sport in each classification for non-coed teams.
  1. Schools are aligned on a regional basis for classes 2A through 7A.
  2. Class A will have a Sectional competition.
  3. An open division (all classifications) will be held for coed competition.
  4. All schools are allowed to have only one varsity competition team.
  5. The term "all-girl" refers to all-female teams throughout this section.
- B. All cheerleading competitions must be conducted according to the rules of the "National Federation Spirit Rules Book" and the "GHSA Competitive Cheerleading Manual." The GHSA cheerleading manuals are posted on the GHSA web site. The NFHS Spirit Rules Book may be purchased from the GHSA office.
- C. The maximum number of competitions for a varsity cheerleading team is six (6), plus region and state competitions. In order to be eligible to compete in Region/Sectional/State, a team must compete in at least three (3) sanctioned competitions during the competitive regular season in the division they declare (All-girl or Coed).
  1. All competitions must be sanctioned by the GHSA by June 1.
  2. GHSA sanctioned Cheerleading competitions may include member schools only or schools from other states who are members of their state association. This excludes non-member high schools and all middle schools.
  3. Cheerleading exhibitions are not allowed at any GHSA sanctioned invitational tournament.
  4. Cheerleading coaches, certified teachers and Community Coaches may not be involved in any way during the school year with a competition not sanctioned by GHSA that involves cheerleaders on their school's team.
  5. Only coaches who meet the criteria of By-Law 2.50 are eligible to assist teams in the competitive setting. Any others assisting a team in any manner at a GHSA competition will be guilty of illegal coaching.
  6. Groups that are not members of the GHSA may NOT perform at any time before, during, or after the competition without approval from the GHSA office.
  7. Officials will be paid for a minimum of twelve (12) high school teams. (See Appendix F for fee schedule).
- D. Deadlines for the competitive season are as follows:
 

|   |             |
|---|-------------|
| 1. Request Sanction of Regular Season Invitational Tournament                             | - June 1    |
| 2. Declaration of Non-Coed and Coed   | - October 1 |
| 3. Register to enter Regular Season Invitational Tournaments                              | - August 1  |
| 4. Cancellation of tournaments that do not make   | - August 10 |
| 5. Confirmation of tournaments submitted with list of teams competing                     | - August 20 |
| 6. Submit rosters <b>electronically</b> on <a href="http://app.ghsa.net">app.ghsa.net</a> | - October 1 |
- E. A competitive cheerleading team is comprised of a maximum of sixteen (16) performers.
  1. A team mascot (if used) is included as one of the 16 performers.
  2. A school may have a roster greater than 16 performers, and may use any combination of eligible cheerleaders in any competition in each specific division.
  3. All team members must be dressed in the appropriate adopted school uniform that displays the school identification (i.e., letter, monogram, mascot symbol, etc.) NOTE: The mascot is exempt from this uniform rule.
- F. The competitive area is a 42'x42' blue cheerleading mat, and the routine must be performed within the boundaries of the competitive area. Mats must have a minimum thickness of 1 3/8 inches.
  1. A full set of cheerleading mats (42'x42') must be used in all competitions including invitationals, regional, and state competitions. (Directions for proper placement of mats can be found in the GHSA Cheerleading Manual).
  2. Only approved GHSA coaches, competitors and officials are allowed in the competitive area.

3. Only team members may act as spotters.
  4. Non-competitors (i.e., alternates, coaches) may not assist during the routine.
  5. All mats should be placed on the floor horizontally facing the judges. Center of the mat should be marked with tape. The floor will be considered out-of-bounds.
  6. It is recommended, but not mandatory, that cheerleaders practice stunting on one or more 6'x42' cheerleading mats prior to performing stunts in a team routine.
  7. Middle school and high school events must be considered separate events. Middle schools may not be placed in rotation with high school teams. The arena should be cleared between the two events and reopened for the sale of tickets prior to the beginning of the high school competition.
- G. The competitive routine must include both cheer and dance.
1. Tumbling skills are permitted only within the body of the routine.
  2. Tumbling skills may not be performed as a part of the entrance to or exit from the competitive area.
  3. Poms are the only props allowed in a competitive routine.
- H. The length of the routine shall be a maximum of two minutes and thirty seconds (2:30), timed by an official timer.
1. The routine must begin within thirty (30) seconds of the head judge's signal. Failure to do so shall result in a five-point deduction for delay of the meet.
  2. Teams may begin from any position inbounds, and the time of the routine will begin with the first word, musical sound, or movement of any team member.
  3. The routine ends on the last word, musical sound, or movement of any team member.
  4. If the routine ends with a pyramid, the final dismount is not timed.
  5. There is no minimum/maximum time limit for music in the routine.
  6. If the routine is longer than the allotted time, a deduction of five (5) points for every fifteen (15) second period or portion thereof will be assessed.
- I. Each school is responsible for the preparation and presentation of the music in its routine, and for complying with all copyright laws (*NOTE: music must be submitted in the ClicknClear portal.*)
1. The principal must review the music to be used in the school's routine, and must stipulate that the music is in good taste for high school students and acceptable for the morals of their community.
  2. Each school must furnish a high-quality version of their music.
  3. The coach or team representative is responsible for starting and stopping the music during the competition.
  4. Schools are responsible for furnishing their own equipment and music for use in the practice/warm-up area.
- J. Winners in the competitions will be determined by the highest point total from the judges. The rules for breaking ties are explained in detail in the Competitive Cheerleading Guide. Ties will be broken by culminating the scores of jumps, tumbling, stunts and pyramids and subtracting the deductions.
- K. Prior to any disqualification for a rules violation, the Head Judge must call a conference at the conclusion of competition, and the majority of the judges must agree the violation occurred.
- L. **Judges' decisions are final.**
- M. In all competitions, all judges must be registered with the GHSA and must have completed the GHSA training program.
1. A minimum of five judges and two safety judges will be used at all competitions, plus scorers and timer.
  2. Judges must be secured by the GHSA office.
- N. Five percent (5%) of the gross receipts from all invitational competitions shall be paid to the GHSA office.

#### **REGION/SECTIONAL COMPETITION:**

- A. Each school is allowed to enter one team in the region competition for the all-girl division. There are no region competitions in Class A nor in the coed division.
1. Entry notification and roster must be sent to the Region Secretary (or GHSA Office for Class A and Coed) according to deadline dates.
  2. **All** rosters must be submitted to the GHSA office **electronically**. NOTE: Substitutions may be made at any time after the roster has been submitted.
  3. The principal must approve the music being used.
- B. Teams will advance to the state competition as follows:
1. All teams (2A through 7A) will attend Sectionals in combination with the region competition. The top sixteen (16) teams will advance to the finals.



2. Class A teams will compete at a Sectional Tournament to determine the top 16 teams to advance.
- C. A panel of judges to be used at invitationals, region, sectional, and state competitions will consist of seven (7) judges to make up three (3) panels. More than one set of judges may be used if necessary.
- D. Five percent (5%) of the gross receipts from the region competition must be paid to the GHSA office.
- E. Region/Sectional competitions will be held on Saturday, November 4, 2023. The region secretaries involved with each region shall determine the procedures for finances, awards, number of judges, etc. The sites can be found on the GHSA web site.

**COED COMPETITION:**

- A. There will be a separate Open Meet competition (all classifications) for Coed teams.
  1. Having one or more males constitutes a coed team.
  2. Once a team has declared the Coed division of competition, they will not be able to switch to another division without approval from the GHSA.
  3. Coed teams and non coed teams may not compete against one another in the regular season.
  4. The Coed Sectionals will be held on Saturday, November 4, 2023, at Ola High School. The top sixteen (16) teams will advance to the State Championship.
  5. The Coed State Championship will be held on Saturday, November 11, 2023, at the Macon Centreplex. NOTE: The GHSA office has the authority to make adjustments in the Coed format depending on the number of teams declared Coed.

**STATE COMPETITION:**

- A. The Cheerleading State Championships will take place **November 10-11, 2023, at the Macon Centreplex**. There will be two sessions per day and the arena will be cleared and cleaned between sessions. If attending, please make sure your ticket is for the correct session. The exact schedules for the two days will be published on the Cheerleading page of the GHSA web site ([www.ghsa.net](http://www.ghsa.net)) prior to the beginning of the event.
- B. Flash photography of **any** kind (cameras, cell phones, iPads, etc.) will **not** be allowed during the competition.
- C. **Finances:** Net receipts will be divided with the GHSA receiving 40% and 60% divided among the participating schools. Each participating team will be allowed **free admission** for a maximum of 20 cheerleaders, two coaches and one music person.

**GAME DAY COMPETITION RULES**

- A. **Game day cheerleading** is a coed state championship sport with as many divisions as deemed necessary by the number of teams competing. Schools are allowed to have one (1) varsity team in this competition. The **State Championship** will be held on a date and at a site to be determined. Exact information will be published on the GHSA web site ([www.ghsa.net](http://www.ghsa.net)) prior to the event.
- B. The Game Day competition team can be comprised of any combination current sideline and competition cheerleaders at that school, or any eligible student attending that school.
- C. The maximum number of Game Day competitions is three (3) in addition to the State Game day competition in February.
  1. All Game day competitions must be sanctioned by the GHSA by *July 1*.
  2. Judges will be contracted through Varsity.
  3. Cheerleading coaches, certified teachers and Community Coaches may not be involved in any way during the school year with a competition not sanctioned by the GHSA.
- D. A team should have a minimum of seven (7) and a maximum of 24 participants.
- E. Traditional game day uniform is required.
- F. The use of signs, poms, flags, and megaphones are allowed and encouraged for performances. The use of additional props is not permitted.
- G. **Music**
  1. Schools must use recorded marching band music for the fight song and Band Chant categories.

2. All use of music must be compliant with U.S. Copyright Laws.
  3. Neither The GHSA nor Varsity Spirit is responsible for obtaining any necessary permission or licensing of the recorded music used by a school team during the course of the GHSA Game Day Invitational.
  4. Fight Song /Band Music
    - (a) If a high school marching band records their school's original fight song, they will need to get the school's permission to use the song and recording.
    - (b) If a team legally acquires a recording of a band playing a popular recording from an authorized provider (iTunes, Amazon, etc.), the song can be used as long as no edits are made to the music (other than for timing purposes).
    - (c) A team cannot use a recording of their band playing a popular song (a cover) or other music without the proper permissions or the band becoming a preferred provider.
- H. Schools will be judged in the following categories:
1. Band chant
  2. Situational response
  3. Crowd Leading
  4. Fight Song

## SECTION 5 CROSS COUNTRY

### GENERAL INFORMATION:

- A. Cross Country is a team championship sport for boys and girls that is held on a Region basis for ALL classes.
- B. The distance for both boys and girls Cross Country will be approximately three (3) miles or five (5) kilometers.
- C. All GHSA Cross Country meets will be run in accordance with the rules as published in the National Federation Track and Field and Cross Country Rule Book with any exceptions as may be found in this section.
- D. The maximum number of competition dates in Cross Country shall be 10, exclusive of region and state competitions.
  1. It is permissible for coaches to use "split squads" during the regular season. However, the use of split squads will count as two (2) of that school's maximum allowed competitions.
  2. Any meets involving eight (8) or more schools must be approved by the GHSA Executive Director in accordance with the process found in By-Law 2.64.
  3. No individual athlete may compete in more than one (1) race per day.
- E. All competitors shall have legal uniforms in compliance with GHSA and NFHS uniform rules.
- F. *The use of WBGT for ALL Cross Country contests is mandated as follows:*
  1. *WBGT must be measured 15 minutes prior to start of contest and coaches notified.*
  2. *If WBGT is equal or above 86.0 F, an ice immersion tub must be present and ready for use at finish line.*
  3. *If WBGT is equal or above 88.0 F, A minimum of two (2) hydration stations must be placed throughout the racecourse as well as at the finish line.*
- G. Beginning and ending dates for practice and competition can be found at the front of this publication.
  1. There will be no interscholastic practices in Cross Country.
  2. Athletes may run in non-GHSA events as long as they do not represent their school, do not wear the school uniform, and are not coached at the event, *or transported to the event*, by their high school coach ("unattached runner").
  3. Communication through electronic devices is not allowed during competition.
  4. The State Championship course is off limits beginning August 1 of each year until all state championships are concluded (unless a GHSA sanctioned/scheduled meet is run during the regular season on the course and a school participates in the event).

### REGION COMPETITION:

- A. The initial team roster of twelve (12) runners must be submitted *on MileSplit GA*. Changes to the roster may be made until the deadline established by each region.
  1. Coaches are to list runners in priority order: the top seven (7), then the selected five (5) alternates.
  2. Region Secretaries *should close registration after the Region deadline*.
- B. 1. Four (4) teams in each Region (classes A through 7A) will advance to the State Meet.
  - a. All qualifiers must be determined by Saturday, October 28, 2023 (All Classes).

- b. Region qualifiers must be finalized by **electronic submission** on MileSplit GA within 48 hours of the completion of the Region Meet; but not later than 9:00 a.m., on Monday, October 30, 2023.
  2. The first six (6) individual finishers from each region in ALL classes will qualify for the State Meet regardless of whether they are a member of a qualifying team.
- C. Cross Country rosters should list twelve (12) contestants. No replacements may be made in the list submitted to the Region Meet Director. Any seven (7) of the twelve (12) may run in the Region or State.

#### STATE MEET:

- A. The State Cross Country Meet for all classifications will be held at Carrollton High School on the dates indicated on the Beginning and Ending Dates table at the front of this publication. The running order may be found on the Cross Country page of the GHSA web site ([www.ghsa.net](http://www.ghsa.net)).
  1. **There will be an admission fee posted on the GHSA web site for all spectators.**
  2. The Meet Director will be **Craig Musselwhite**, 678-910-3022.
  3. Awards will be presented at the conclusion of each classification.
- B. A minimum of five (5) and a maximum of 12 runners will be allowed **free admission** for each team that qualified. Individual qualifiers also will be admitted free. Coaches will be admitted on their GHSA coaching passes.
  1. The first five (5) finishers for each team will count for the total team score.
  2. Each team must begin and end the competition with a **minimum** of five (5) runners. If, for any reason, a qualifying team does not have five (5) runners, that team will not be allowed to compete in the State Meet.
  3. Each member of a qualifying team, as well as individual qualifiers from each region, is considered to be in contention for individual honors.
  4. Practice times and Team Instructions for the state meet will be announced on the Cross Country page of the GHSA web site ([www.ghsa.net](http://www.ghsa.net)) approximately one month prior to the State Meet.

### SECTION 6 DANCE

#### GENERAL INFORMATION:

- A. Dance is a co-ed state championship sport with as many divisions as deemed necessary by the number of teams competing.
- B. Beginning and ending dates for practice and competition may be found at the beginning of this publication.
- C. All dancers must be turned in on the proper eligibility forms and ruled eligible by the GHSA office.
- D. All dancers must have a physical examination on file in the school office before they may try out, practice, or perform.
- E. All dance coaches must complete a GHSA Rules Clinic or the school will be fined.
- F. Tryouts may be held in the spring any time after the state competition is completed and before the end of school. Tryouts may be held again after school begins in the fall. Tryout can be held for 10 consecutive days.
  1. Students must be enrolled at a school in order to try out for that school's dance team. A student may be enrolled in only one school at a time.
  2. Enrolled migrant students may try out for a dance team, but may not represent the school at the varsity level during the school year until the migratory sit-out period has ended.
  3. Students must meet academic eligibility requirements in order to try out.
- G. Dance teams are allowed to attend camps after the last day of school until Aug. 1.

#### COMPETITION RULES:

- A. All Dance competitions must be conducted according to the rules of the National Federation Spirit Rules book and the GHSA Dance Competitive Dance Manual. The Dance manual is posted online on the GHSA web page ([www.ghsa.net](http://www.ghsa.net)). The NFHS rules book can be purchased from the GHSA office, online at Amazon.com, or from the NFHS site.
- B. Schools are allowed to have only one (1) varsity competition team.
- C. All teams must consist of at least 7 dancers, but not more than 20 dancers. If the number of competitors falls below the number required to compete in that division, the team will be allowed to compete in the division they have entered *with a five-point penalty per dancer below the minimum.*

- D. A school may have a roster greater than 20 performers, and may use any combination of eligible dancers in any competition in each specific division. A team's second routine must be comprised of at least half +1 participants of the original performers.
- E. All team members must be dressed in appropriate uniforms/costumes approved by their school. All NFHS rules for apparel must be applied. No hard jewelry is permitted. *Hair must be secured and must NOT extend below the waist.*
- F. Dance apparel is restricted as follows:
1. When standing at attention, apparel must cover the midriff.
  2. *Fabric must cover the skin from the bra line to the knees (tights, body liners, pants, etc.).*
  3. Dancers must wear footwear that is appropriate for the activity. (see NFHS rulings)
- G. The maximum number of competitions for a varsity dance team is six (6), plus the state competition. *To qualify for state, a team's selected routine must be scored in at least three (3) GHSA sanctioned competitions before state.*
1. All competitions must be sanctioned by the GHSA by October 1.
  2. GHSA sanctioned Dance competitions may include member schools only or schools from other states who are members of their state association. This excludes non-member high schools and all middle schools.
  3. Dance coaches, certified teachers and Community coaches may not be involved in any way during the school year with a competition not sanctioned by the GHSA that involves dancers on their school's team.
  4. Only coaches who meet the criteria of By-Law 2.50 are eligible to assist teams in the competitive setting. Any others assisting a team in any manner at a GHSA competition will be guilty of illegal coaching.
  5. Groups that are not members of the GHSA may NOT perform at any time before, during, or after the competition without approval from the GHSA office.
  6. Invitational competitions should have a minimum of 12 high school routines participating in the event. Officials will be paid for a minimum of 12 high school teams. (See Appendix F for fee schedule)
  7. Middle school and high school events must be considered separate events. Middle schools may not be placed in rotation with high school teams. GHSA judges may be hired as officials for middle schools or solo, duets, or trio events; however, it is not mandatory.
- H. Deadlines for the competitive season are as follows:
- |   |         |
|---|---------|
| 1. Request Sanction of Regular Season Invitational Tournament | Oct. 1  |
| 2. Register to enter regular season invitational tournaments  | Oct. 15 |
| 3. Submit rosters for "Notification of Entry" online          | Feb. 1  |
- I. The competitive area is the basketball court inside the boundary lines.
1. Only approved GHSA coaches, competitors, and officials are allowed in the competitive area.
  2. Non-competitors may not assist during the routine.
- J. The length of the routine shall be a *minimum of one minute, 40 seconds* and not exceed two (2) minutes.
1. The routine must begin within 30 seconds of the cue, "Welcome to the floor, \_\_\_\_\_ High School." Failure to do so could result in a five-point deduction for delay of meet.
  2. Teams may begin from any position inbounds, and the time of the routine will begin with the first note of the music. *NOTE: Inbounds is determined as the area inside the end lines and side lines of a basketball court.*
  3. The routine ends with the last note of the music or choreographed movement.
  4. If the routine is longer *or shorter* than the allotted time, five (5) points for every 15 seconds will be deducted.
- K. Each school is responsible for the preparation and presentation of the music in its routine, and for complying with all copyright laws. (*NOTE: music must be submitted in the ClicknClear portal.*)
1. Music should be free of any explicit language or violent implications can result in a disqualification.
  2. Each coach is responsible for providing a high quality version of their own music for the DJ.
  3. Principals have the responsibility of approving the music chosen for performances. Notation is provided on the dance rosters page for each school (found in MIS site)
  4. *Delays in music could cause a meet delay deductions of five (5) points.*
- L. Winners of the competition will be determined by the highest point total from the judges across all styles of dance.
1. A winner for each style of dance will be named. The following styles of dance will structure the categories: Hip Hop; High Kick; Jazz/Lyrical and Pom.
  2. An overall winner for each classification will be named. Classifications, depending on size of school, will be determined based on number of teams who have entered in each classification.
  3. Prior to any disqualification or noticeable deduction for a rules violation, the Head Judge must call a conference at the conclusion of competition, and the majority of the judges must agree the violation occurred.
- M. Judges' decisions are final.

- N. In all competitions, all judges must be registered with the GHSA and must have completed the GHSA training program.
1. A minimum of 5 judges, including 1 tech judge will be used at all competitions.
  2. Judges must be secured by the GHSA office.
  3. 5% of the gross receipts from all invitational competitions shall be paid the GHSA office.

**STATE COMPETITION:**

- A. The State Championship will be held at a site to be determined. In each session, teams will rotate by divisions. A total of six (6) judges will be used per division.
- B. No flash photography of any kind will be allowed during the competition.
- C. Finances: Net receipts will be divided with the GHSA receiving 40% and 60% divided among the participating schools. Each participating team will be allowed free admission for a maximum of 24 dancers, 2 coaches and 1 music person.

**SECTION 7  
FOOTBALL**

**REGULAR SEASON:**

- A. Football is a state championship sport in each classification, and schools are aligned on a Region basis.
1. In the reclassification year (see Article III of the GHSA Constitution), all regions will meet after reclassification has been finalized by the Executive Committee and after any sub-divisions have been finalized and cross-over games have been arranged.
    - (a) No schedule is valid until the plans of all regions have been approved.
    - (b) Plans for determining the ranking and breaking ties of the four region representatives for playoffs must be drawn by the regions before the football season begins.
    - (c) All contracts should be drawn to coincide with the two-year reclassification period and show the day, date, time, opponent and game site.
  2. Each school must file its football schedule with the GHSA Executive Director no later than **March 1**, each year.
    - (a) The schedule must show the day, date, time, opponent, and game site.
    - (b) The GHSA Executive Director must be notified concerning any changes made to the schedule after the submission date.
    - (c) Any changes made for a region game must be made prior to the date for beginning football practice.
      - (1) Any change of opponent after that date will cause the game not to count as a sub-region or region game.
      - (2) Limitations regarding schedule changes shall also be construed to prevent a school from canceling a game when such a game could affect the region and/or sub-region standings.
      - (3) A change in date or time with the same opponent is not considered a change affecting region or sub-region status.
    - (d) Contracts with officials for varsity games must be signed by June 1 each year, and copies of the schedules must be submitted to the proper officials association(s).
    - (e) Each school must have a signed contract for its football scrimmage, and a school may be fined for failure to comply with that contract.
    - (f) There may be a \$250 penalty for schools that change their football schedules after June 1. (NOTE: Appeal procedures are available.)
- B. Schools must enter team schedules, rosters and weekly game/meet results during the season on MaxPreps and be responsible for updates as needed. This information will support statewide media, event programs, broadcasts partners and GHSA Region Standings. Teams are encouraged to maintain team/individual statistics on MaxPreps.
- C. All GHSA football games must be played according to the rules as published by the National Federation of State High School Associations, and any other rules found in this section.
- D. The number of football games allowed (excluding state playoffs) is ten (10).
1. No varsity football game may be played on a night preceding a school day without specific authorization from the GHSA Executive Director.
  2. Only one football game may be played per week (the schedule week is a traditional week - Sunday through Saturday) by the same level team (varsity/sub-varsity) except in the case of make-up games due to special circumstances that have been approved by the Executive Director.
  3. A single sub-varsity game played on a night before a school day may start no later than 6:30 p.m. The first game of two sub-varsity games played on a night before a school day may start no later than 5:30 p.m.

4. Football players playing on both the varsity and one sub-varsity team are limited to six quarters of competition in any seven (7) calendar day period beginning with the date of the varsity game. The penalty for violation of this rule will be forfeiture of the game in which the violation occurred and a \$1,000.00 fine.
5. The football season ends for a team or individual when that team, having completed its regular-season schedule, is eliminated from playoff competition or wins the State Championship.
6. All JV games will be played with 10-minute quarters. If there is an 8th grade student(s) on the JV team, then 8-minute quarters must be played.
7. Schools may play 10 Mini Games at the JV level, instead of seven (7) regular games, the combination of which can not exceed the current 28 quarters allowed for sub-varsity play. Each Mini Game will be one-half of a regular game. Four (4) schools would meet at one site, with two schools playing a half and then the other two schools playing a half. Officials would be paid the regular fee for a single game.
8. *Any football contest MUST have an on-site WBGT monitor and take measurements 15 minutes prior to the start of the contest and again during halftime. The following requirements for hydration breaks must be followed:*
  - (a) *Kick-off WBGT equal or above 87.0 F – referees will take a mandatory hydration break at or near the 6-minute mark of each quarter lasting three (3) minutes (change of possession or touchdown and PAT). All participants must remove their helmets and no coaches are permitted on the field at this time. It is recommended that players who are actively engaged in the competition and come to the sideline remove their helmets and hydrate until such time that they re-enter the field of play.*
  - (b) *Kick-off WBGT equal or above 90.0 F – referees will take a mandatory hydration break at or near the 4-minute and 8-minute mark of each quarter lasting 3 minutes (change of possession or PAT). All participants must remove their helmets and no coaches are permitted on the field at this time. It is recommended that players who are actively engaged in the competition and come to the sideline remove their helmets and hydrate until such time that they re-enter the field of play.*

9. **Regulation of 7-on-7 Contests**

*Clarification of Terminology: 7-on-7 play between 2 or more teams where there are NOT any officials present will be viewed as a "PRACTICE" and therefore will fall under the GHSA Interscholastic Contests and Practices (Section 2.60) and the Practice Policy for Heat and Humidity (Section 2.67) along with the following guidelines:*

- (a) *Teams that participate in back-to-back play periods lasting a maximum of 60 minutes, must be followed by a 30-minute break in a shaded area before resuming activity.*
- (b) *It is recommended that medical personnel (athletic trainer or EMT) be present during said practice session.*
- (c) **7-on-7 play between 2 or more teams in the presence of officials will constitute a "CONTEST" and therefore will follow guidelines listed below:**
  - (1) *WBGT Temperature will be taken and recorded prior to the start of all contests.*
  - (2) *The host school will notify the Head Official and both Head Coaches of the WBGT reading prior to the start of the contest.*
  - (3) *Hydration breaks will be implemented when the WBGT is equal or above 90.0 F. Referees will take a mandatory three-minute hydration break at the 10-minute mark of each contest.*
  - (4) *Ice immersion tub on-site and ready for use when WBGT is equal or above 86.0 F.*
  - (5) *Medical Time-out taken prior to start of contest to discuss procedures for possible heat exhaustion or heat stroke treatment.*
  - (6) *Teams that participate in back-to-back play periods lasting a maximum of 60 minutes, must be followed by a 30-minute break in a shaded area before resuming activity.*
  - (7) *It is recommended that medical personnel (athletic trainer or EMT) be present on each field during all contests.*

E. Football **practice** may begin five consecutive weekdays prior to July 31st (**NOTE:** Schools are reminded of the special **Heat and Humidity Acclimatization** restrictions listed in **By-Law 2.67-b** pertaining to football).

1. In the first five days of practice for any student, the practice may not last longer than two (2) hours, and the student may wear no other protective football equipment except helmet and mouthpieces. **NOTE:**
  - (a) The time for a session shall be measured from the time the players report to the practice or workout area until they leave that area.
  - (b) During acclimatization practices, teams may hold a walk-through as long as there is at least a two-hour break between the two activities.
2. Beginning July 31st, any student may practice in full pads and may practice a maximum of two (2) times in a single calendar day under the following stipulations:
  - (a) A student must have participated in five conditioning practices wearing no other protective football equipment except helmet and mouthpieces before being allowed to practice in full pads.
  - (b) In a single calendar day:
    - (1) No single session may last longer than three (3) hours.
    - (2) If two (2) practices are held, the TOTAL time shall not exceed five (5) hours.
    - (3) There must be at least a three-hour time of rest between sessions if two (2) sessions are held.
    - (4) There may not be consecutive days of two-a-day practice sessions. All double-session days must be followed by a single-session day or a day off.

- (5) A walk-through may not be held on days when two practices are conducted.
- (c) These procedures are derived from recommendations created by the Inter-Association Task Force for Preseason Secondary School Athletics Participants in the paper "Preseason Heat-Acclimatization Guidelines for Secondary School Athletes."
3. **Full contact** should be limited during practices as well as during activity outside of the traditional fall practice. (**Note:** No limitation is placed on activities defined below as "AIR, BAGS or CONTROL" contact.)
- (a) For purposes of this by-law, the following definitions shall apply: **AIR** - Players run a drill unopposed without contact; **BAGS** - Players run a drill against a bag or another soft-contact surface; **CONTROL** - Players run a drill at assigned speed until the moment of contact and one player is pre-determined the "winner" by the coach. Contact remains above the waist and players stay on their feet; **THUD** - Players run a drill at competitive speed through the moment of contact with no pre-determined "winner." Contact remains above the waist, players stay on their feet and a quick whistle ends the drill; **LIVE ACTION** - Players run a drill in game-like conditions and is the only time that players are taken to the ground; **FULL CONTACT** - Contact which meets the definition of Live Action or Thud.
- (b) **Pre-Season & Spring Practice & Summer Contact Camps:**
- 1) Full contact shall be allowed in no more than 2 consecutive practice days per week;
  - 2) Full contact during practice shall be limited to not more than 45 minutes per day;
  - 3) Full contact during practice shall be limited to not more than 135 minutes per week; and
  - 4) During any twice-daily practice, only one session per day shall include full contact.
  - 5) In Summer Contact Camps, the only form of Full Contact allowed is **Thud**.
  - 6) Schools will be limited to attending no more than two (2) padded Team Contact Camps per summer: one in June for two days during a three consecutive day period, and one in July for two days during a three consecutive day period (no more than four (4) days total). There must be at least four (4) participating schools or the camp cannot be held.
- (c) **Regular & Post Season Practice:**
- 1) Full contact during practice shall be allowed in no more than three (3) practice days per week;
  - 2) Full contact during practice shall not be allowed on more than two (2) consecutive days;
  - 3) Full contact during practice shall be limited to not more than 30 minutes per day;
  - 4) Full contact during practice shall be limited to not more than 90 minutes per week.
- (d) **Written Practice Plans:** A written practice plan in compliance with this by-law shall be prepared in advance by the head coach prior to every practice and maintained by the school for a period of at least twelve (12) months. Such practice plans shall be made available to the GHSA upon request.
- (e) **Violations:** The penalty to be imposed upon any member school found to have violated this by-law in any substantial manner shall be as follows:
- 1) First Offense: A fine of not less than \$500 nor more than \$2,500 per violation at the discretion of the Executive Director.
  - 2) Second Offense: The school shall be placed on probation and shall not be eligible to participate in post season play.
4. From the end of school in the spring until the first day of preseason practice, players may wear no other protective football equipment except helmets and mouthpieces for all voluntary workouts and passing league games. Institutional heat policies are also in effect for voluntary workouts supervised by school personnel.
5. All applications for team summer camps at GHSA schools or other facilities must be submitted to the GHSA office by May 1, and all subsequent correspondence to complete the application must be completed by May 15. Coaches for these players **must** verify that the participants have had acclimatization practices for five days immediately preceding the camp.
6. Equipment in summer (contact) camps is limited to helmets and mouthpieces, shoulder pads, and compression-style shorts (girdles) that have thigh pads and/or girdle pads. **NO FOOTBALL PANTS OR KNEE PADS CAN BE WORN AT ANY TIME DURING SUMMER.**
- F. All varsity football games shall be played with a minimum of five (5) officially-dressed field officials who are registered under the GHSA plan for registering officials. The officiating crew also shall have an electric clock operator whose only duty is to operate the game clock.
1. In all games, the host school must provide some type of dressing facilities for officials at or near the game site that can also be used to hold the pre-game conference.
  2. During the regular season, the host school is responsible for providing a crew to work the sideline chains. These individuals must be responsible adults.
  3. In accordance with By-Law 2.71-c, the host school is responsible for providing security escorts for the officials at all regular season and playoff games.
- G. The following regulations are in place for GHSA football games.
1. All GHSA football games will have a twenty (20) minute halftime **unless** both school administrators agree in writing by Thursday of game week to shorten the halftime period to fifteen (15) minutes, or unless NFHS weather-condition rules supersede.

2. Artificial noisemakers, except airhorns and whistles, are legal at football games. Illegal noisemakers are to be confiscated when visible and/or used.
  3. Bands are not to play during live-ball situations.  
NOTE: This includes the situation in which there is no timeout and the teams are in a huddle.
    - (a) If, during a football game, a team claims interference with communications due to band noise, the Referee shall give a warning to one or both head coaches and the bands must cease playing.
    - (b) If there is a second offense by the same school's band, an unsportsmanlike conduct penalty will be imposed against that school's team.
  4. During the state playoff series, a crew of seven (7) field officials will be used.
  5. Fans shall not be allowed to enter the playing field either before the game or at halftime to form a tunnel for players to run through.
  6. In the regular season, a school may utilize a visible 25/40-second clock as long as the time is visible on both ends of the field and the clock is operated by a paid game official.
  7. Football stadiums may never be completely dark during the use of any flashing stadium lights. The ability to see from one endline to the opposite endline must be maintained at all times before, during and after the game, until the officials have left the competition area.
- H. **Spring Football Practice** for each school year may be held from February 1 until the end of the school year, consisting of 10 practices spaced over 13 consecutive school days. (**Note:** Spring and fall scrimmage games and jamborees are considered to be extensions of practice as far as eligibility rules are concerned.)
1. Schools must choose by February 1 each year as to whether they will have spring football practice.
    - (a) If a school conducts spring practice, all preseason practice schedules remain the same (See item D. 3(b) for a listing of contact limitations).
    - (b) If a school chooses not to conduct spring practice, the team will be allowed to hold an additional (second) scrimmage game or controlled scrimmage against another school, or a jamboree with three teams playing a half against the other two teams, in the fall.
    - (c) Schools hiring a new coach may appeal to the Executive Director to change an earlier decision.
  2. Schools that have scrimmage game/games canceled or suspended by inclement weather will have the following options:
    - (a) Play on another night during the same calendar week (defined as Sunday to Saturday.) Sunday play is not allowed.
    - (b) Play during another week when the school does not have another scrimmage or regular season game scheduled. (**Note:** No scrimmage game may be played after a school's first varsity contest.)
  3. Schools which participate in Spring Practice are allowed to play a spring game/scrimmage with another school, or a jamboree with three teams playing a half against the other two teams, in place of their last (10th) practice of the spring (**Note:** Restrictions under by-law 2.62 (f-2) & (f-3) will apply).
  4. A football coach on the payroll of one school district, but under contract to another school district for the following year, may help with spring football at the new school, if the arrangement is satisfactory with both systems.
  5. Students enrolled in grade 8 in a middle school or junior high school that is a feeder school to the high school may participate in Spring Practice at that high school.
  6. No student (eighth grade or above) may participate in more than ten (10) days of Spring Practice, and may participate for no more than one (1) school.
- I. In case of a game being terminated in the first half (suspended game), By-Law 2.93-c must be followed.  
NOTE: All varsity football games must be played to completion. Any interrupted game must be replayed from the point of interruption. The school that is behind in the score may choose not to continue the game and the score will be recorded as it was at the point of interruption. NOTE: Teams will not be allowed to play two football games in the same week, except when making up a suspended game with the permission of the Executive Director.
- J. During warmups before the game and at halftime there shall be a division of the field, and neither team shall enter the other team's portion of the field. That division shall be as follows:
1. Before the game: each team shall occupy the space from their own 45-yard line to the endline of their goal line. Neither team shall occupy the area between the 45-yard lines.  
EXCEPTION: When kicking, each team shall have the area between the opponent's 45-yard line and kicking team's end zone in the side zone area on the same side of the field as their bench. Kickers shall kick toward their end zone.
  2. Re-entering the field before the game and at halftime: each team shall have the portion of the field between their bench and the near edge of each goal post - i.e., field divided lengthwise.
- K. *Overtime is **mandated** for all games between schools of the same classification. Overtime MAY NOT be played between teams of different classifications in the regular season unless both head coaches agree to play overtime in the presence of the Referee prior to the start of the game. In Sub-Varsity play, the two schools, regardless of classification, MAY agree before the game not to play overtime if tied at the end of regulation.*



1. This procedure involves giving both teams opportunities to score from the 15-yard line until the tie is broken.
  2. Overtime games are exempt from the 11:30 p.m. GHSA curfew.
- L. When there is a **competitive imbalance between teams**, the coach of a team trailing by 30 points or more at halftime may choose to play the second half with a running clock. Quarters will remain at 12 minutes.
1. If the coach does not exercise the option of the running clock, the third quarter will be played with regulation timing.
  2. If the point differential reaches, or remains, 30 or more points during the third quarter, the clock will still run according to rule for the remainder of the third quarter, but the fourth quarter will have a running clock mandated.
  3. A running clock means the clock will be stopped only:
    - (a) after a touchdown and until the ball is kicked off.
    - (b) during deliberations for penalty administration.
    - (c) during charged timeouts or official's timeouts
  4. A game that is reduced in time by use of a running clock shall constitute a "completed" game to meet other by-law considerations.

### GHSA OVERTIME PROCEDURE

1. There will be a 3-minute intermission between the end of regulation play and the coin toss to start the overtime procedure.
2. The captains will meet for the coin toss, and the winner may choose one of the following:
  - (a) Be on offense first
  - (b) Be on defense first
  - (c) Choose the end of the field on which to play
3. The ball is placed on the 15-yard line and the offense keeps the ball until:
  - (a) The ball is turned over on downs (NOTE: The team on offense can gain a first down.)
  - (b) The defense gains possession of the ball (ball is dead immediately)
  - (c) The offense scores a touchdown or field goal
  - (d) The offense misses a field goal
4. After the first offensive team completes its possession, the opposing team gets its opportunity from the 15-yard line.
5. If the game remains tied after each team has had an offensive possession, there will be a 2-minute intermission and the team that lost the first coin toss has the first option for the second possession.
6. For each additional overtime period (i.e., an offensive possession by each team) the original coin toss options are alternated.
7. Beginning with the third overtime period, a team must attempt a 2-point try after a touchdown.
8. Each team is allowed one timeout per overtime period. No timeouts may be carried over from regulation play.

### REGION PROCEDURES:

- A. To qualify for championship consideration in a region or sub-region, a school must play a minimum number of games with schools in its region as determined by the region and the GHSA Reclassification Committee.
1. In any region or sub-region in which there are six (6) or less schools, if each school plays two (2) games, both games will count as region games. In any other case where two (2) schools have played more than once during the regular season, only the first game scheduled shall count in the region standings.
  2. Any school playing a non-region or non sub-region schedule (i.e., not in consideration for a region championship) will not have its games count for or against any opponent.
- B. The GHSA Executive Director, upon presentation of evidence to show that a school can not secure the required number of games in a region or sub-region, may authorize each school to substitute any number of games in any classification or region to qualify for championship consideration. NOTE: A request for substitution of game(s) must be submitted prior to September 1.
- C. Four (4) representatives from each region will enter the post-season playoffs.
1. Each region will determine the way to designate the four representatives and their placement in the region (i.e., first place, second place, third place and fourth place).
  2. In case there is a **tie between teams** and the region does not have a different written tie-breaker plan, the following procedures will be used (NOTE: **The use of mini-games to break ties is no longer allowed**):
    - (a) If two teams tie, and one of the teams has defeated the other in a regular schedule region game, the winner shall have the higher placement. Three or more tied teams shall first be considered in sets of two-way ties. NOTE: If three or more teams are tied, use head-to-head record among the tied teams to break ties for seeding. Only utilize points to break ties among teams when the ties are a perfect triangle, with each team having the same record among the tied teams.

- (b) If two teams tie and the tied teams split or have not played each other in a region game (no round robin), the team with the greater sum of winning margin using the following Point System, shall have the higher placement.
- (c) If more than two teams remain tied after applying "a" above, the following Point System shall be used to eliminate all but two teams. Tabulate the sum of the winning margins of each team's region games as indicated in the following:  
**POINT SYSTEM:**
  - (1) If the margin of victory is more than 13 points, only 13 points shall count.
  - (2) Losses shall be tallied as 0 (zero) points.
  - (3) Forfeited games: Offended teams shall receive 13 points when tabulating the sum of the winning margins for breaking region ties.
- (d) After tabulating the sum of the winning margins, all teams except the two (2) with the greater sums shall be eliminated, and the selection process shall begin again with paragraph "a" above.
- (e) If teams remain tied after the above procedures are applied, the playoff representatives shall be determined by a coin toss. The coin toss, supervised by the REGION OFFICERS, shall be used to eliminate all but two (2) teams, and then the process shall begin again with paragraph "a" above.
- (f) In the event the region is eligible for more than one playoff representative, each subsequent playoff representative shall be chosen by reapplying the procedure above.
- (g) All regions will use the adopted procedures for breaking ties that occur in the order of standings when round robin schedules are completed.

**STATE PLAYOFFS:**

- A. All rounds of games after the end of the regular season are considered part of the state playoff structure.
  - 1. In **ALL Rounds** except the Finals, the higher-seeded team will host. In the **Quarterfinal Round**, if both teams have the same seeding, a "universal" GHSA coin flip (see By-Law 4.39), will determine the host site.
  - 2. In **ALL Rounds** except the Finals, game date and time will be set by mutual agreement. If that agreement is not possible, the GHSA Executive Director will finalize the arrangements. If an administrator does not attend the meeting at which the playoff contract is negotiated, the coach shall be authorized by the Principal to negotiate and sign a binding contract.
  - 3. In **ALL Rounds** except the Finals, one half of all permanent and temporary seats shall be offered to the visiting team, and it is the responsibility of the home team to regulate the seating so as to guarantee designated seating to the visiting team's supporters.
  - 4. In **ALL Rounds** except the Finals, there should be adequate parking space with a recommendation of one (1) space for every four (4) spectators.
  - 5. In **ALL Rounds** except the Finals, security shall be provided at the site in the ratio of at least one officer per 500 spectators.
  - 6. In **ALL Rounds** except the Finals, facilities for officials to dress, shower, and/or hold meetings shall be made available at the site or nearby.
  - 7. It is **mandatory** to have emergency medical personnel at the site of **all football playoff games**.
  - 8. **Playoff ticket prices** are as follows (NOTE: Only babies in arms do not need a ticket.):
    - First Round: \$8.00 (All classes)
    - Second Round: \$10.00 (All classes)
    - Quarterfinals: \$12.00 (All classes)
    - Semifinals: \$15.00 (All classes)
    - Championships: TBA
    - (a) **Through the semifinal round**, high school level students of the participating schools may purchase presale tickets at a discount of \$2 off regular price. Students may purchase one (1) ticket each from their schools at this discounted price.
    - (b) **Certified staff members** who work at the participating schools **ONLY** will be allowed free admission **through the semifinal round** with proper identification.
- B. In order to host a **Semifinal Round** playoff game, a school must meet the following site requirements:
  - 1. Permanent seating requirements:
    - (a) One seat equals 24 inches in width. Exception: each theatre style seat (with back and arm rests) will count as one seat regardless of the width of the seat.
    - (b) All seats must be at least 15 feet from playing field.
    - (c) Total seating capacity for each class is as follows:
      - Class A.....2,000 seats
      - Class 2A & 3A.....2,500 seats
      - Class 4A & 5A.....3,000 seats
      - Class 6A & 7A.....4,500 seats

- (d) Each principal of a school in the playoffs shall certify that the school stadium meets or does not meet football playoff requirements. If a principal certifies such information falsely, then \$2,000.00 of such school's share of the gate receipts of the contest held in the non-complying stadium shall be paid to the opposing team.
- (e) The GHSA will mediate with both teams involved when there are concerns about the safety of a venue in regard to seating limitations.
- (f) The **higher-seeded** team in the **Semifinal Round** will be the **host team**. If they do not have a stadium that meets GHSA minimum standards, they may secure a suitable site.
- (g) The **higher-seeded** team may use portable seating to bring its home stadium seating capacity up to the GHSA minimum in order to host the game as long as (NOTE: Any portable seating brought in for games in earlier rounds also must meet these specifications):
- (1) The seating meets the standards of the industry and is installed by professional installers.
  - (2) All seats provide clear sight lines to the field of play.
  - (3) No costs for the temporary seating are taken out of game receipts.
  - (4) Seating requirements for a semifinal game may be waived upon written agreement of the Principals of the competing schools that the host's stadium will be adequate and with the approval of the GHSA Executive Director.
- (h) If both teams in the **Semifinal Round** have the **same seeding**, the "universal" GHSA coin flip (see By-Law 4.39), will determine the host team under the following procedure:
- (1) The winner of the coin flip will have the opportunity to bring its stadium up to specifications as outlined in item "g" above, or to secure a suitable stadium (if their stadium doesn't meet GHSA specifications.)
  - (2) The winner of the coin flip will have until 4:00 p.m., on the Monday before the game to commit to bringing their stadium up to specifications or to secure a suitable site.
  - (3) If the winner of the coin flip can't secure a suitable site, or bring theirs up to specifications, the opponent will then be awarded the home game, assuming their stadium meets requirements.
  - (4) If neither school meets or exceeds GHSA standards, and the winner of the coin flip can't find a suitable stadium or bring its stadium up to the specifications, the Executive Director will designate a neutral site.
- (i) The GHSA will provide a supervisor at all semifinal games.
2. The stadium shall have adequate working space in the **press box** as follows (NOTE: the first priority for access to the press box after the clock operator and the PA announcer is the working media):
- |                          |                |
|--------------------------|----------------|
| Classes A, 2A & 3A.....  | 30 linear feet |
| Class 4A.....            | 40 linear feet |
| Classes 5A, 6A & 7A..... | 50 linear feet |
- C. All **Championship Round** games will be played December 11-13, at *Mercedes-Benz Stadium*. These games will be known as the "GHSA/Tommy Guillebeau Football Championships."
1. The expense and revenue shares by classification will be as follows:  
7A - 17.5%, 6A - 15%, 5A - 15%, 4A - 13%, 3A - 12%, 2A - 11.5%, A (Div. 1 & Div. 2) - 16% (8% each)
  2. A "Video Review" system will be used in all championship games, the procedure for which will be published on the GHSA web site.
  3. The exact schedule for the championship games will be published on the GHSA web site.
- D. Financial Procedures:
1. Total game receipts will include all revenue from ticket sales plus any payments for radio or television broadcasting, and will not include money from the sale of programs and concessions.
  2. All band chaperones and other support personnel must have tickets.
  3. The division of game receipts will be handled as follows:
    - (a) From the gross receipts:
      - (1) Twelve percent (12%) will be sent to the GHSA Office along with a financial report. Each Football Financial Report Form shall include the number of spectators admitted with a GHSA pass, along with a copy of the sign-in sheets listing the names and numbers of the passes used.
      - (2) The visiting team shall receive reimbursement for travel expenses in the amount of \$5.00 per mile (one way) taken from the game receipts and guaranteed by the host school. NOTE: If the game is played at a neutral site, both teams will be reimbursed for mileage.
      - (3) **FOR ALL ROUNDS OF THE PLAYOFFS: The game officials will invoice GHSA and GHSA will pay the officials.**
      - (4) The HOST school shall receive a fee of 7% of the gross gate receipts.
    - (b) After items in Section "a" have been paid, the remainder shall be divided equally between the two teams.
    - (c) Local service charges, stadium charges, lights, cost of operating personnel, etc., are not to be deducted prior to the division of funds, and are considered a part of the expenses of the host school.
  4. Broadcasting procedures are handled as follows:
    - (a) The GHSA office will process radio contracts in all rounds of the playoffs. The fee schedule and regulations for radio broadcasts may be found in the Broadcast section 2.80.

- (b) Outlets wishing to televise or webcast football games must contact the GHSA office for contract terms.
- 5. Financial arrangements for the championship games are designated by the GHSA Executive Committee.
- E. Game officials will be assigned by the GHSA Office in all playoff rounds. Officiating crews shall include seven (7) field officials, clock operators, and three (3) chain crew members.

### FLAG FOOTBALL

#### GENERAL INFORMATION

- A. Girls' Flag Football is a state championship event organized on an Area basis in multiple divisions (as needed) with eight (8) areas in each division, playing during the late Fall each year. Schools must indicate their desire to play Flag Football on the "Intent to Participate" by March 1 each year.
- B. The maximum number of play dates allowed (not including the State Tournament) shall be 10 and one (1) invitational tournament (maximum of four (4) games).
  - 1. Host schools shall schedule a minimum of two (2) games each playing date.
  - 2. Teams shall not play more than (2) games each playing date.
  - 3. Teams are allowed to play (1) scrimmage/jamboree play date after the first official practice date, and prior to the first regular season game of either participating school.
  - 4. Beginning and ending dates are listed on the GHSA Calendar and in the front of this publication.
  - 5. Try-outs may be held on five (5) days anytime after May 1 and prior to the final day of school attendance with the following restrictions:
    - (a) The five (5) days are not required to be consecutive and schools may use a non-school facility.
    - (b) Limited to current enrolled students maintaining athletics eligibility for the subsequent school year (grades 9-11), and current year 8th graders (rising 9th graders).
    - (c) The 5th and final day of the tryout period may be used as an official jamboree event with a minimum of three (3) schools participating.
- C. Schools must enter team schedules, rosters and weekly game/meet results during the season on MaxPreps and be responsible for updates as needed. This information will support statewide media, event programs, broadcasts partners and GHSA Region Standings. Teams are encouraged to maintain team/individual statistics on MaxPreps.
- E. **PLAYING RULES** – Official Girls Flag Football playing rules may be found on the GHSA web site.
- F. **STATE TOURNAMENT**
  - 1. Each area will be responsible for determining the four (4) teams advancing to the State Tournament, with sixteen (32) teams in each division advancing to the first round.
  - 2. In the first three (3) rounds, the higher seed in each of the four-team quadrants will host two games to be played on the same date. A universal coin toss will determine the host schools for the second or quarterfinal rounds when teams of equal seeds are left in the same quadrant.
  - 3. The semifinals and championship finals for each division will be played at a neutral site to be determined by the GHSA Executive Director.

### SECTION 8 GOLF

#### GENERAL INFORMATION:

- A. Golf is a state championship event for boys and girls held on an Area basis in Classes 1A through 7A. Each class in 2A through class 7A will be divided into four Areas by combining two regions. Area assignments can be found on the Golf Home Page at [www.ghsa.net](http://www.ghsa.net). An Area Coordinator should be assigned by the two combined regions to schedule and direct the area golf tournament. In Class A, four Areas will be assigned after separating into Division 1 and Division 2. An Area Coordinator should be assigned to schedule and direct the area tournaments. In addition to team competitions, there is also an individual competition.
- B. All GHSA golf matches shall be conducted in accordance with the "Rules of Golf" as published by the United States Golf Association (USGA). *Please refer to the GHSA Postseason HARD CARD for the Rules of Play for competition.* Exceptions specific to all GHSA competitions include:
  - 1. Players may use push/pull carts in regular season and post season matches. Motorized carts or caddies are not permitted.
  - 2. Range finders and GPS devices will be allowed in match and tournament play with the following stipulations:
    - (a) In each grouping (2-4 players), if any player uses a "range finder" then all players will have access to the distance information.

- (b) Any player using a device who does not share the distance information with other players in his grouping, when asked, will be subject to disqualification for a serious breach of etiquette.
  - (c) Single function GPS devices that measure distance are allowed. Any device that performs multiple functions may be used for distance only. Use of any other functions will lead to **disqualification**.
  - (d) Smart Phones/Watches that include yardage book applications may be used during play. Any use of these devices is limited to scoring as well as what is covered under the USGA rules that govern “artificial devices.”
3. The use of spectator carts will be based upon their availability at each course. Only spectators with a legitimate handicap will be allowed to rent a cart when there is a limited availability.
- C. *School Rosters must be submitted **electronically** on the GHSA MIS system by April 15, 2024. A school may list up to 10 golfers for the Postseason. Lineup changes/substitutions may be made at the Area/Sectional/State level but only using those golfers listed in MIS.*
- 1. *In addition, each School Roster must be input in iWanamaker (the GHSA golf app) by April 15, 2024. Results from Area/Sectional/State Tournaments must be verified and finalized both in iWanamaker as well as the GHSA MIS system*
  - 2. *Golfers not submitted by the deadline are ineligible to compete in the postseason.*
  - 3. *Entering an ineligible player in a postseason event is punishable by disqualification.*
- D. The number of matches allowed (excluding region, sectional and state tournaments) is twelve (12) playing dates.
- 1. A 9-hole match played prior to the **last play date** will count as 1/2 playing date.
  - 2. Schools may use one (1) Saturday during the regular season as a playing date that does not count as one of their twelve (12) allowed play dates.
- E. Beginning and ending dates for practice and competition can be found at the front of this publication.
- 1. There will be no interschool practice or scrimmages in golf.
  - 2. A golf match may not begin prior to the end of the school day with the exception of post-season tournaments.
- F. A maximum of two (2) golf coaches may confer with their golfers anywhere on the course with the exception of the greens, so long as there is no delay in play. **Note:** Conversations with or suggestions from any other person is prohibited (First violation: warning. Second violation: 2-stroke penalty. Third violation: disqualification).
- G. In the event that a match ends in a tie during the regular-season or post-season competition, a “team sudden-death playoff” will be used.
- Boys:**
- 1. All six (6) players will play the first playoff hole.
  - 2. The first foursome will include the top two players from each team, the second foursome will include the 3rd and 4th players from each team, and the final foursome will include the other two players.
  - 3. The best four (4) scores of each team will count.
  - 4. If the teams are still tied, all players will proceed to the next playoff hole.
- Girls:**
- 1. All four (4) players will play the first playoff hole in A and 2A, all five (5) players will play in 3A-7A.
  - 2. The first foursome will include the No. 1 and No. 2 players from each team, the second foursome will include the No. 3 and No. 4 players from each team, and in 3A-7A the last twosome will include the No. 5 players from each team.
  - 3. The best two scores of each team will count in classes A and 2A; the best three scores will count in classes 3A through 7A.
  - 4. If the teams are still tied, all players will proceed to the next playoff hole.
- NOTE:** Any ties for **Individual** championship in Area and/or State must be played off using a “sudden death” format.
- H. It is permissible for coaches to use “split squads” during the regular season. If both squads are playing in the same event, it will count as only one (1) of the school’s maximum allowed competitions. However, if the split squads are playing in two different events, it will count as two (2) of that school’s maximum allowed competitions.
- I. A maximum score of 10 per hole will be used in all competitions, regular-season and GHSA post-season.
- J. All golf coaches must complete the GHSA/GSGA online rules clinic for golf or the school will be fined. Dates for the clinic may be found on the GHSA web site.

**AREA TOURNAMENTS:**

- A. Each Area Tournament will be an 18-hole event.
1. The Area Director is responsible for communicating details of the Area Tournament to both Region Secretaries that form the Area who will (in turn) communicate to all schools in their respective regions. GHSA will maintain no record of where or when the Area Tournaments are scheduled to be played.
  2. Boys: A team may enter up to six (6) players with the top four scores counting.  
Girls: Classes 3A through 7A: A team may enter up to five (5) girls with the three best scores counting. In Classes A through 2A: A team may enter up to four (4) girls with the best two scores counting.
  3. **In Classes 5A-7A**, the following advancement criteria from the Area Tournament to the State Tournament will apply:
    - a) Each Team Area Champion and Runner-Up will receive an automatic bid to the State Championships.
    - b) Each Team that finishes in 3rd and 4th Place will advance to a Classification Sectional.
    - c) The Area Tournament Director will electronically submit the Area results to [app.ghsa.net](http://app.ghsa.net) no later than 9:00 a.m., on April 30, 2024.
  4. **In Class A through 4A**, the top three (3) teams in the Area tournament will advance to the State Championships.
    - a) Ties for the final qualifying slot(s) must be played off.
    - b) The Area Tournament Director will electronically submit the Area results to [app.ghsa.net](http://app.ghsa.net) no later than 9:00 a.m., on May 7, 2024.
- B. Each Area Tournament will have a team competition and an individual competition.
1. The lowest Individual score not automatically qualifying for the Classification Sectional or the State Championships as a member of a full team will advance to the State Championships.
  2. In the case of a tie for a qualifying slot, the tied competitors must play it off.
  3. Schools that do not have a regular girls or boys team may enter individuals in the Area Tournament to compete for individual advancement to the State Tournament.
- C. Each school will pay an entry fee to participate in the Area Tournament as follows:
1. Boys teams: \$120.00; Girls teams: \$100.00 for 3A-7A, \$80.00 for A-2A; Individuals: \$20.00.
  2. The checks are to be made payable to the golf course to help cover costs.

**CLASSIFICATION SECTIONAL (5A-7A Only):**

- A. Each Sectional Tournament will be an 18-hole event.
1. Details of the tournament will be sent to schools by the Sectional Director.
  2. Boys: A team may enter up to six (6) players with the top four scores counting.  
Girls: A team may enter up to five (5) girls with the three best scores counting.
  3. The following advancement criteria from the Sectional Tournament to the State Tournament will apply: Each team that finishes in 1st through 4th Place will advance to the State Championships.
  4. Ties for the final qualifying slot(s) must be played off.
  5. The Sectional Tournament Director will submit electronically to the GHSA the Sectional Golf Results ([app.ghsa.net](http://app.ghsa.net)). The deadline for this submission is May 8, 2024 at 9:00 a.m.
- B. Each Sectional Tournament will have a team competition and an individual competition.
1. The lowest 2 Individual scores not automatically qualifying for the State Championships as a member of a full team will advance to the State Championships.
  2. In the case of a tie for a qualifying slot, the tied competitors must play it off.
- C. Each school will pay an entry fee to participate in the Sectional Tournament as follows:
1. Boys teams: \$120.00; Girls teams: \$100.00.
  2. The checks are to be made payable to the golf course to help cover costs.

**STATE TOURNAMENT:**

- A. The State Golf Tournaments in all classifications will be held on the dates designated in the Beginning and Ending Dates table at the front of this publication.
1. All State Tournaments shall be 36-hole events. Note: In the case that one of the rounds is canceled due to inclement weather, etc., the tournament will be an 18-hole event.
  2. Details of the state tournaments will be sent to the schools involved by the respective tournament directors or the GHSA office.
  3. Substitutions from the Area/Sectional Tournaments to the State Tournament must be submitted to the Tournament Director no later than 6:00 p.m., the evening before the State Final.

4. Substitutions after the first day of the State Tournament must be submitted to the Tournament Director no later than 8:00 a.m., on the morning of the second round.
- B. All State Tournament sites will be marked and prepared by the Tournament Director and the host club's golf professional. The Georgia State Golf Association will provide officials for the State Tournament to answer questions regarding the Rules of Golf.
- C. The recommended playing distances for all Area, Sectional, and State Tournaments shall be: Boys - 6,500 yards; Girls - 5,500 yards (on Par 72 courses). Adjustments may be made for Par 70 or Par 71 layouts.
- D. Each school will pay an entry fee to participate in the GHSA State Tournament as follows:
1. Boys teams: \$240.00; Girls teams: \$200.00 for 3A-7A, \$160.00 for A-2A; Individual qualifiers: \$40.00.
  2. The checks are to be made payable to the golf course to help cover costs.
- E. A listing of the State Tournament sites will be posted on the GHSA web site ([www.ghsa.net](http://www.ghsa.net)).

### SECTION 9 GYMNASTICS - GIRLS

#### GENERAL INFORMATION:

- A. Girls gymnastics is a state championship event open to schools in all classifications. There will be two championship divisions: A-5A and 6A-7A.
1. Competition in all meets will be held in the following events:
    - (a) Balance Beam
    - (b) Uneven Parallel Bars
    - (c) Vault
    - (d) Floor Exercise
    - (e) All-Around (competition in preceding four events)
  2. The order of competition will be determined by block style.
  3. Open scoring will be used. (**Note: the Capital Cup warm-up format is allowed, but schools will be expected to pay an extra \$10.00 per judge if using this format.**)
  4. Beginning and ending dates for practice and competition can be found at the front of this publication.
- B. The GHSA gymnastics meets will be played according to the rules published by the National Federation of State High School Associations with such GHSA modifications as may be found in this section.
- C. Each school desiring to participate in gymnastics must file its intent by March 1 of the preceding year by filing the form found on the GHSA web site.
- D. The number of regular-season gymnastics meets allowed is 10, including any invitational tournaments.
1. The state elimination series does not count in these meets.
  2. An invitational tournament is defined as a competition involving more than three teams.
  3. All invitational tournaments must be approved by the GHSA Executive Director.
  4. Only two meets per week may be scheduled.
  5. All teams and gymnasts (except when prevented by injury) must participate in a minimum of three (3) GHSA sanctioned varsity meets during the regular season to be eligible to participate in the state Preliminary Meet. If an injury occurs, **a doctor's statement with the date and type of injury and the release date to participate** must be presented prior to the Preliminary Meet. Scan and email the doctor's statement to the [penny@ghsa.net](mailto:penny@ghsa.net).
  6. Schools may organize and conduct invitational tournaments to assist in meeting the three (3) meet requirement.
    - (a) These tournaments may be held outside the school, but must be run by school personnel and must be sanctioned by the GHSA. (**Note: schools hosting a meet are responsible for paying the judges.**)
    - (b) Scores should be submitted to Penny Mitchell by the tournament director as soon as possible to determine rankings to be posted on the GHSA web site.
- E. There will be no interscholastic practice and/or scrimmages.
- F. No exhibitions are permitted during seasonal or invitational meets.
- G. In accordance with NFHS rules, the GHSA limits the number of participants a school may enter in a meet as follows:
1. For regular season meets, the limit is five (5) participants per event.
  2. For invitational meets during the regular season, the limit is four (4) participants per event, unless approved by the tournament director.

3. For post-season meets, the limit is four (4) participants per event (including the All-Around competition).
- H. All gymnastics coaches are required to complete an online GHSA rules clinic as specified in the GHSA By-Laws.
- I. **Tiebreaker Procedure when using three (3) or more judges.**
1. Gymnast's scores are determined by dropping the high and low scores and averaging the two middle scores (the scores must be within range per NFHS rules).
  2. In the event of a tie, an average of all three (3) or four (4) judges' scores will be used.
  3. If a tie still remains, the score of the Chief Judge will be used.
  4. If, after the above steps, a tie still remains, the tie stands.

#### **PRELIMINARY MEET:**

- A. A Preliminary (qualifying) Meet will be held at a site to be determined.
- B. **Qualifying Information:**
1. A total of eight (8) teams will qualify from the A-5A division and eight (8) from the 6A-7A division for the Preliminary Meet by averaging the top three (3) scores during the season. A team's minimum score is determined by compiling the top three (3) individual event scores. In case of a tie for 8th place, the teams tied will qualify for the Preliminary Meet.
  2. A gymnast may qualify for an individual event even if her team does not qualify by meeting the following standards - An all-around score of 34.0 or better in three (3) regular-season meets and/or an individual score of 8.50 or better on Beam and Bars and 9.00 or better on Vault and Floor Exercise in three (3) regular-season meets.
  3. There will be a limit of four (4) qualifying gymnasts per individual event who can represent a school that did not qualify as a team.
  4. If a gymnast qualifies at the Preliminary Meet, but can't advance because of illness or injury, the next individual will move up to take that spot at State Finals.
- C. The general information, entry form and roster form may be found on the GHSA website. Coaches must submit rosters online on the GHSA MIS site by March 15. Changes after this date can be sent to the GHSA office for approval. No changes will be made the week of the Preliminary Meet.
- D. Schools that do not meet the entry form deadline will not be able to enter the Preliminary Meet.
- E. All **individual competitors** must qualify in the Preliminary Meet to advance to the State Finals.
- F. Substitutions made after the Preliminary Meet for **team competitors** must be on the current submitted roster.
- G. Schools that qualify for the Preliminary Meet, but do not attend, will be fined by the GHSA.
- H. The top four (4) teams in each division, and the top eight (8) individuals in each event and All Around at the Preliminary Meet will advance to the State Finals.

#### **STATE MEET**

- A. The "Dr. Lucia B. Norwood GHSA State Championship" Finals will be held on Friday, April 19, 2024, at a site to be determined. The GHSA Coordinator is Penny Pitts Mitchell in the GHSA office (e-mail: penny@ghsa.net).
- B. In all Preliminary and State Meets, expenses are paid from the gross gate receipts, including the cost of officials, and the balance is sent to the GHSA Office.
- C. In all Preliminary and State Meets, a maximum of 10 athletes and two coaches will be given **free admission**.

### **SECTION 10 LACROSSE**

#### **GENERAL INFORMATION:**

- A. Lacrosse is a classified event with three (3) state championships: Class 7A, Classes A-4A, and Classes 5A-6A.
- B. All Lacrosse games will be played according to the rules published by the National Federation with such GHSA modifications as may be found in this section.



- C. Notification of entry in Lacrosse must be filed in writing with the GHSA office no later than March 1, for the upcoming school year so that teams may be placed in Areas for competition.
- D. The number of Lacrosse games allowed (not including state tournaments) shall be eighteen (18). If a region/area chooses to hold a region/area tournament, those games must be included as part of the 18-game total allowed. Beginning and ending dates for practice and competition can be found at the front of this publication.
- E. All GHSA Lacrosse games shall be played with a minimum of two officially-dressed officials who are registered under the GHSA plan for registration of officials.
- F. For evening games, a single game must begin no later than 7:30 p.m., and a doubleheader must begin no later than 6:00 p.m. If the host school does not offer a warm-up location for the visiting team, there must be a minimum 30-minute warm-up period between games for both teams. If a warm-up location is provided, then a minimum 20-minute interval between games is required.
- G. Sub-varsity games will be limited as follows:
  - 1. Boys *and girls* will play four 10-minute quarters.
  - 2. No overtimes will be played in sub-varsity competition.
- H. When there is a competitive imbalance between two teams in a contest, the game will be shortened as follows: If a team is more than ten (10) goals down at any time, the remainder of the game will be played with a running clock that will stop only for timeouts and injuries *in both boys and girls competitions*.
- I. Games that are tied at the end of regulation will be handled according to the procedures outlined in the appropriate rule book as follows:
  - 1. BOYS: Any game that ends in a tie will be resolved by playing a sudden victory overtime period as outlined in Rule 3-4 of the NFHS Boys Lacrosse Rules Book.
  - 2. GIRLS: For all regular season games in girls lacrosse that end in a tie, overtime will be played according to sudden victory overtime rules (Rule 4-7) published by US Lacrosse and endorsed by the NFHS. This format will also be used in all tournaments where advancement is necessary.
- J. *The use of WBGT for ALL contests is mandated as follows:*
  - 1. BOYS: *WBGT must be measured 15 minutes prior to start of contest, coaches and officials must be notified.*
    - (a) *If WBGT is equal or above 86.0 F, an ice immersion tub must be present and ready for use.*
    - (b) *If WBGT is equal or above 88.0 F, Referee's will take a 3-minute hydration break at or near the midway point of each 12-minute period (ball out of bounds/foul assessed or goal scored). Teams to the bench area during hydration break, no coaches permitted on field.*
  - 2. GIRLS: *WBGT must be measured 15 minutes prior to start of contest, coaches and officials must be notified.*
    - (a) *If WBGT is equal or above 86.0 F, an ice immersion tub must be present and ready for use.*
    - (b) *If WBGT is equal or above 88.0 F, Referees will take a 3-minute hydration break at or near the midway point of each half (ball out of bounds/foul assessed or goal scored). Teams to the bench area during hydration break, no coaches permitted on field.*
- K. Teams arriving late for a scheduled contest by thirty (30) minutes or more shall forfeit the game, and shall be responsible for payment of the officials unless prior arrangements are made in a timely manner. Consideration will be given to emergency situations over which the traveling school has no control. The host school has the responsibility of notifying the officials of any changes in the schedule.
- L. Schools must enter team schedules, rosters and weekly game/meet results during the season on MaxPreps and be responsible for updates as needed. This information will support statewide media, event programs, broadcasts partners and GHSA Region Standings. Teams are encouraged to maintain team/individual statistics on MaxPreps.

#### **AREA COMPETITION:**

- A. Each Area shall have a written tie-breaker procedure in order to seed teams for the playoffs.
- B. An Area may choose to use the GHSA tie-breaker procedure:
  - 1. Winning percentage against all teams in the Area.
  - 2. Head-to-head competition among the teams that are tied.
  - 3. Goals allowed in head-to-head competition between teams that are tied.
  - 4. Goal differential in head-to-head competition between teams that are tied (maximum of 10 goals per game).

5. Goals allowed in all Area games.
6. Goal differential in all Area games (maximum of 10 goals per game).
7. At any point in the process where ties can be broken so that only two teams remain tied, consideration of head-to-head competition will be invoked. If the tie is completely broken for all teams involved at any step in the process, the tie-breaker process is completed.

C. If the Area is subdivided, then the same tie-breaker procedure should be used for both subdivisions.

#### POST-SEASON COMPETITION:

- A. If championship games end in a tie, the rulebook procedure for breaking a tie is followed (see Lacrosse Section I).
- B. Admission fee for rounds 1-4 is \$7.00 for a single playoff game and \$10.00 for a doubleheader. Admission for championship finals is \$15.00 and shall be played at a neutral site TBD.
- C. Finances:
  1. The GHSA will receive 12% of the gross gate receipts.
  2. Officials will be paid by the host schools out of the gate receipts.
  3. The visiting team's mileage will be paid at .80 per mile one way.
  4. Any remaining receipts will be shared by the participating teams.
  5. Host school(s) will be responsible for security, facility fees, maintenance costs, etc., and these expenses will not be taken out of gate receipts.
  6. At neutral-site games, each participating team is allowed **free admission** for a maximum of 25 players and team essential personnel. Coaches will be admitted with a GHSA coaching pass.
- D. In order to host a state playoff game, the host school must be able to provide the following:
  1. seating for 700 attendees (calculated at 24 inches per seat) Note: GHSA may waive this stipulation with approval of the visiting school.
  2. adequate restroom facilities for the size of the crowd;
  3. a dressing room or locker room for the visiting team.

### SECTION 11 RIFLERY

#### GENERAL INFORMATION:

- A. Air riflery is a state championship co-ed event open to GHSA schools of all classifications.
  1. Each school desiring to participate in riflery must file its intent by March 1, of the preceding school year by filing the form found on the GHSA web site ([www.ghsa.net](http://www.ghsa.net)).
  2. Following notification of entry, each school will be assigned to an Area for competition that will be overseen by an Area chairperson. Teams will be notified of Area assignments when the total number of teams entering is determined.
  3. Contestants in riflery must be certified as being eligible through the GHSA Office. All rifle team athletes must have a sports physical on file at the school.
  4. Beginning and ending dates for practice and competition can be found at the front of this publication.
  5. GHSA Riflery team members may be used by JROTC programs in JROTC program competitive events. Athletes used by both GHSA Riflery programs and JROTC program competitive events must be currently enrolled in JROTC and be entered as a JROTC unit and not as a school team. They may not enter competitions or tournaments unless there is a JROTC competition category.
- B. Competitions will be Open Class, which permits use of Precision or Sporter Class equipment using Precision air rifle rules. The latest edition of the "NATIONAL STANDARD THREE-POSITION AIR RIFLE RULES" (published by the National Three-Position Air Rifle Council, Camp Perry, P. O. Box 576, Port Clinton, OH 43452 - also available on website: <http://thecmp.org/air/national-standard-three-position-air-rifle-rules/>) will govern all GHSA matches except the following:
  1. The regular season, Sectional and Semifinal course of fire will be the team event 4x3x10. All matches will be shoulder to shoulder. **Postal matches will not be accepted.** Team members will be distributed equally between relays if more than one relay is used.
  2. Except at the State Championship, Sectional, Semifinal and tie-breaker competitions, the coach may assist team members (without disturbing other athletes), during preparation, changeover and sighting periods, but may not physically assist the athletes in loading, cocking or adjusting the sights. After each of these periods, the coach must be behind the firing point.

3. The "two scorers" referred to in National Standard Rule 8.5 will consist of a scorer from each team if outside scorers with no interest in the outcome are not used.
  4. The amount of protest period time (Rule 8.2) should be established by each Rifle Area prior to start of season or agreed upon by both coaches prior to the beginning of the match.
  5. The following safety regulations are mandatory for ALL competitions, training and practices: An adult, approved by the school, must be present at all times that students have access to rifles. Clear Barrel Indicators (CBIs) will be in all rifles when not firing. They will be inserted in the rifle when taken out of storage or cases. The CBI must visibly extend beyond both ends of the barrel when installed. The CBIs may be removed only during preparation and sighting, record firing, changeover (after athlete is in a firing position), and sighting times. They will be reinserted after each position stage and the rifle must be grounded. CBIs must be inserted anytime someone goes forward of the firing line or removes their rifle from the firing line. CBIs may be removed after the Range Officer gives the "You may discharge air downrange" command, then must be inserted after discharging air and left inserted until air rifles are placed in gun cases.
  6. Approved scoring methods are manual and electronic as listed in the National Three Position Air Rifle Rules. The host school determines which to use.
- C. Each Area shall draw up schedules for each team in the Area.
1. Each Area schedule must be filed with the GHSA Office.
  2. The home or host schools should fax or e-mail team and individual scores to the area chairperson by the beginning of the next day (noon or earlier) after completion of the match.
  3. Four competitors' scores comprise a team's score. Five may be used in post-season GHSA competition with the top four (4) scores counting as the team score. Areas may organize regular-season competitions as they elect in regard to the number of team members involved as long as only the top four (4) scores count as the school's team score.
  4. If a team has less than four competitors, it must forfeit the match (receiving a loss and the other team receiving a win). If both schools agree to compete with the forfeiture in place, the team scores do not count, but the individual scores from both teams will count as GHSA official individual scores and there will be no additional penalty besides the forfeiture. Forfeitures must be communicated with the opposing team before the scheduled match start. Forfeitures **without extenuating circumstances** will result in fines, with the fines increasing for each forfeiture **without extenuating circumstances**. A panel of three coaches selected by the State Coordinator will decide if extenuating circumstances warrant no fine. Decisions of that panel may be appealed to the Executive Director.
  5. Standings will be determined by won-loss results. A team may compete against only one other team in a given regular season match. Ties will be broken using National Standard Rule 8.6. If tie breaking rules are exhausted and the match is still tied, the match will be scored as a tie and each team credited with one-half win and one-half loss. In cases of identical won-loss records, the results of their season competition against each other will determine standings. If still tied then a shoot-off match will be held.
  6. Before the start of the regular season, each Area will establish structure for determining Area winners and Sectional seedings. The Area will also appoint an appeals committee to handle protests and appeals in area competitions. NOTE: Decisions by the Area Appeals Committee may be appealed to the Executive Director when it is believed that Area procedures have been violated.
  7. Area competition must be completed by February 13, 2024. Final Area standings must be reported to both the State Coordinator and the GHSA office *no later than noon* on February 14, 2024.

#### RESULTS REPORTING:

- A. Area chairpersons should report weekly results in regular season and Sectionals by *noon* Monday of the following week.
- B. Results of Semifinals and tie-breakers (if required to determine the two invitational Championship teams) must be reported by the day following the competition.

#### SECTIONAL COMPETITION:

- A. The first six teams in each Area will advance to the Sectionals to be fired on February 26, 2024, or earlier if agreed upon by both Area chairpersons involved. The Area chairperson of the top three seeded teams in his/her area will coordinate the matches and report the results to both the State Coordinator and to the GHSA office not later than *noon* February 27, 2024. Sectional and Semifinal brackets can be found in Appendix B.

#### SEMIFINAL COMPETITION:

- A. The thirty (30) teams winning the Sectional competition will advance to the State Semifinal competitions to be fired on March 5, 2024 or earlier if agreed upon by both Area chairpersons involved. The Area chairpersons will coordinate

the matches. All chairpersons will report the results and **all** individual qualifiers to the State Coordinator and to the GHSA office not later than *noon* March 6, 2024. **TEAMS AND ALL QUALIFYING INDIVIDUALS MUST BE REPORTED FOR THEM TO COMPETE IN THE STATE CHAMPIONSHIP.** Qualifying individuals' scores submitted by the Area Chairperson on regular- and post-season results fulfill this requirement.

#### STATE COMPETITION:

- A. The fifteen (15) teams winning the Semifinal competitions and the two (2) teams with the highest losing scores in the Semifinals qualify to compete at the State Championship. Any ties to determine the two additional teams to advance to the championship (identical high losing scores) will be broken with another match to be held on March 11, 2024 or earlier if agreed upon by Area chairpersons involved. The higher-seeded team will host. If teams have the same seeding, a coin toss will determine the host site. Area chairpersons must report results of these tie-breaking matches to the State Coordinator and to the GHSA office not later than *noon* March 12, 2024.
- B. Competing team members at the Championship also compete for the individual competition. All other GHSA competitors firing 292 or better in a regular season GHSA Area match or in the Sectionals, Semifinals or tie-breaker also qualify for the state individual competition if their team does not qualify. Schools with more than five competitors with the 292 or better qualification may use five of these competitors as a team plus their additional qualifiers may compete for the individual championship. Finals procedures will be used in determining the state individual standings, but will have no effect on team standings.
- C. The State Rifley Championship will be held on March 16, 2024 at a site TBD. The GHSA State Coordinator for Rifley is **Lisa Kelley** - 404-307-8041; email: [lkelly1@yahoo.com](mailto:lkelly1@yahoo.com).

### SECTION 12 SOCCER

#### GENERAL INFORMATION:

- A. Soccer is a state championship event for boys and girls played in the Spring season. Schools in classes 1-A, Division 1 through 7A are aligned in Regions. Class 1-A, Division 2 will be an Area sport in soccer.
- B. All soccer matches will be played according to the rules published by the National Federation, and all National Federation recommendations for "State Adoption" have been adopted by the GHSA. Sub-varsity matches are limited to 35-minute halves.
- C. The number of soccer matches allowed (not including state tournaments) shall be eighteen (18). If a region chooses to play a region tournament, those matches must be included as part of the 18-game total allowed. Beginning and ending dates for practice and competition can be found at the front of this publication.
- D. All GHSA varsity soccer matches shall be played with one or more officially-dressed officials who are registered under the GHSA plan for the registration of officials.
- E. *The use of WBGT for ALL Contests is mandated as follows:*
  - 1. *WBGT must be measured 15 minutes prior to start of contest, coaches and officials must be notified.*
  - 2. *If WBGT is equal or above 86.0 F, an ice immersion tub must be present and ready for use.*
  - 3. *If WBGT is equal or above 88.0 F, Referees will take a 3-minute hydration break at or near the midway point of each half (ball out of bounds/foul assessed or goal scored). Teams to the bench area during hydration break, no coaches permitted on field.*
- F. Teams arriving late for a contest by thirty (30) minutes or more shall forfeit the match, and shall pay the officials unless prior arrangements are made in a timely manner, and both teams agree to start the game late or reschedule it. Consideration will also be given to emergency situations over which the traveling school has no control. The host school has the responsibility of notifying the officials of these changes.
- G. A student may not participate in more than three (3) halves of soccer per day except in a tournament setting, when a player may play two full matches in a calendar day.
- H. During regular season competition played between teams of different classifications, there will be no overtime procedure invoked when regulation play ends with a tie score, unless both coaches agree and inform the match officials prior to the start of the match. During regular season competition between schools in the same classification, and during region/area and state playoff competition, the **overtime procedure** described in item "E" later in this section will be invoked.

- I. In accordance with the National Federation allowance for a state adoption (Rule 7-1-5), when there is a **competitive imbalance** between the teams, the match will be shortened as follows:
  1. If a team is seven (7) or more goals down at the midpoint of the first half, that will be considered the end of the half, and the teams will play a twenty (20) minute second half.
  2. If a team is seven (7) or more goals behind at halftime, the second half will be restricted to twenty (20) minutes.
  3. When a team trails by ten (10) or more goals at halftime, the game will be terminated.
- J. All soccer matches between schools from the same classification must be played to completion. Matches that are interrupted by weather or mechanical difficulties will be replayed from the point of interruption unless the team that is behind chooses not to complete the match.
- K. In accordance with GHSA By-Laws, soccer coaches will be required to attend a GHSA rules clinic. Failure to do so will result in a fine for the school for each coach who does not attend.
- L. Schools must enter team schedules, rosters and weekly game/meet results during the season on MaxPreps and be responsible for updates as needed. This information will support statewide media, event programs, broadcasts partners and GHSA Region Standings. Teams are encouraged to maintain team/individual statistics on MaxPreps.

#### REGION COMPETITION:

- A. When a Region has not adopted its own tie-breaker method, the following **Tie-Breaking Procedure** will be used for seeding purposes:
  1. Record against all teams in the Region/Area.
  2. Winning team in head-to-head competition between schools that are tied.
  3. Goals allowed in head-to-head competition between schools that are tied.
  4. Goal differential in head-to-head competition between schools that are tied (maximum of three (3) goals per game).
  5. Goals allowed in all Region/Area games
  6. Goal differential in all Region/Area games (maximum of three (3) goals per game). **Note:** When figuring "goals allowed" and "goal differential" in matches decided by penalty kicks, the winning team will have one (1) goal added to its game score and the losing team will have no goals added regardless of the number of penalty kicks that were made by either team.
  7. In any step of the tie-breaking process if a three-way tie is broken so that all ties are broken, that step determines the placements. If two teams remain tied after a step is completed, revert back to head-to-head record to break the tie. If the tie cannot be broken, move to the next step.
- B. If Regions/Areas sub-divide, then the same tie-breaking procedures (A1 through A7) should be used.
- C. For Region/Area and State competition, if the score is still tied at the end of the second overtime period, the penalty kick procedure will be used to determine the winner.
- D. Financial procedures for all Region/Area playoffs will be determined by the Region/Area. The host school is responsible for payment of officials. The admission fees for State playoffs begin immediately after Region/Area winners are determined.
- E. **OVERTIME PROCEDURE:**
  1. The overtime will consist of two (2) ten-minute periods, which will be played to their entirety.
  2. A coin toss shall take place to determine which team will put the ball in play for the first overtime period.
  3. If the score remains tied following the overtime periods, a "**shootout**" of penalty kicks will determine the winner.
  4. The head referee shall choose the goal at which the penalty kicks will be taken.
  5. Each coach will select any five (5) eligible players (including goalkeeper) to take the kicks.
  6. A coin toss shall be held with the team winning the toss having the choice of kicking first or last.
  7. Teams will alternate kickers, and there is no follow up on the kicks.
  8. The defending team may change goalkeepers prior to each kick.
  9. Following five kicks from each team, the team with the greater number of successful kicks will be given one (1) point and declared the winner.
  10. If the same number of penalty kicks are successful for each team, each coach will select five (5) different eligible players who will kick in a "sudden victory" situation. Each team will have an opportunity to kick in each round of the sudden victory procedure.
  11. If there is no "sudden victory" winner after five (5) kicks, the process will be repeated until a winner is determined.

**STATE COMPETITION:**

- A. Four teams from each Region in classes 1-A, Division 1 through 7A will advance to the state tournament. In Class 1-A, Division 2, six (6) teams from each Area will advance to the state tournament.
1. Region/Area winners must be determined by the date indicated on the Beginning and Ending Dates table at the front of this publication.
  2. It is the responsibilities of the host team to furnish game balls beyond those furnished by the GHSA
  3. In the event that two schools involved cannot agree on the arrangements for the series (dates, times, etc.) the GHSA Executive Director will make a ruling to cover the situation.
  4. Prior to the final round, the higher seeded team will host, unless the competing teams have the same seeding. In that case, a coin flip will designate the host team.
  5. All Championship games will be played on the dates indicated on the Beginning and Ending Dates table at the front of this publication. Admission prices and exact schedules and sites will be posted on the GHSA web site prior to the finals.
  6. At neutral-site games, each participating team is allowed free admission for a maximum of 25 players and team essential personnel. Coaches will be admitted with a GHSA coaching pass.
  7. In the Finals, the team **on the bottom** of the official GHSA bracket will be the designated "home" team for purposes of uniform requirements only. Regardless of prior seeding, the team on the bottom of the bracket shall wear dark jerseys and socks for the game.
- B. Finances:
1. The GHSA will receive 12% of the gross gate receipts.
  2. Host schools will pay the Officials Association directly for the first and second rounds of the playoffs. Please see Fee Chart for Playoff Fees. (Please see Soccer Financial Forms)
  3. A pre-set amount for game officials fees will be sent to the GHSA office for the Quarterfinal and Semifinal rounds, along with 12% of gross gate receipts, and the GHSA office will be responsible for paying the officials.
  4. The visiting team shall be paid \$.80 per mile (one way) for travel.
  5. After these three expenses are paid the schools involved will share the remaining gate receipts equally.
  6. The host school is responsible for security, facility fees, maintenance costs, etc., and these expenses shall not be taken out of gate receipts.
- C. Admission must be charged at all playoff games. Ticket prices for First, Second and Third Rounds of the State Playoffs are \$7.00 for single games and \$10.00 for doubleheaders. Semifinal Round Ticket prices are \$10.00 for single games and \$13.00 for doubleheaders. All Championship Game tickets are \$15.00.
- D. In order to host a state playoff game, the following site requirements must be met:
1. Seating requirements (seats at 24 inches each):  
A & 2A: 750; 3A: 1,000; 4A: 1,500; 5A, 6A & 7A: 2,000
  2. Adequate restroom facilities must be provided
  3. Dressing area must be provided for the visiting team and the officials.
  4. The playing area must be configured in such a way that spectators must enter through an admission gate.
  5. The field must be sufficiently lighted to allow for night play for all semifinal and championship matches.
  6. Championships matches will be held at neutral sites.
- E. In the post-season tournaments, it is necessary to have team benches located on the same side of the field. This will be true even in situations where fans are kept on opposite sides of the field. Preferably, fans will be on one side of the stadium while Team Benches will be on the opposite side of the field.

**SECTION 13  
SOFTBALL****GENERAL INFORMATION:**

- A. **Fast Pitch Softball** is a state championship event organized on a Region basis in all seven classifications. Beginning and ending dates for practice and competition can be found at the front of this publication.
- B. All softball games will be played by the rules as published by the National Federation of State High School Associations.
- C. The maximum number of softball games allowed (not including state tournament games) shall be: thirty (30) games either head-to-head competition or in invitational or region tournaments.
1. Region tournaments shall be structured so that no school will play more than eight (8) games in that tournament.

2. Schools may not enter any softball tournament other than the region tournament or state elimination series unless such tournament has been approved by the GHSA Executive Director.
  3. Sub-varsity teams are allowed to play 70 percent of their respective varsity team's regular season games. Sub-varsity teams shall not schedule a tournament after they have reached their 70 percent game restriction.
  4. Contracts are required for **all** GHSA member school fastpitch softball games, including invitational tournaments.
- D. All varsity softball games shall be played with officially-dressed officials who are registered under the GHSA plan for the registration of officials. The assignment of officials for regular-season games, invitational tournaments, and sub-region and region tournaments will be made by the GHSA office.
1. The GHSA will assign one or more associations to each school for their games.
  2. The school and the local association(s) will sign a contract for the games that are assigned.
- E. *The use of WBGT for ALL Fastpitch Softball Contests is mandated as follows:*
1. *WBGT must be measured 15 minutes prior to start of contest, coaches and umpires must be notified.*
  2. *If WBGT is equal or above 86.0 F, an ice immersion tub must be present and ready for use.*
  3. *If WBGT is equal or above 88.0 F, Umpires will take a 3-minute hydration break at the beginning and mid-point of inning 3 and continuing until the conclusion of the game.*
- F. The following rule "State Adoptions" have been approved for GHSA play in softball:
1. The game will end when:
    - (a) a team has completed three turns at bat and is fifteen (15) runs behind.
    - (b) a team has completed four turns at bat and is twelve (12) runs behind.
    - (c) a team has completed five or more turns at bat and is eight (8) runs behind.
  2. The courtesy runner rule has been adopted. NOTE: Participation as a courtesy runner does not constitute entry into the game, and does not count as a game played.
  3. The use of a double first base is recommended.
  4. The suspended game rule will be used.
    - (a) When a game is stopped before it becomes a legal game, it is considered to be "no contest" and any replay will begin from the first inning.
    - (b) When a game is stopped after it becomes a legal game and a winner can be determined, the game is completed.
    - (c) When a game is stopped after it becomes a legal game and a winner can not be determined, any replay will begin from the point of interruption.
    - (d) **Exception:** If a State Tournament game is suspended at any point, it shall resume from the point of interruption on the next available date. If that date can not be agreed upon by the competing schools, the GHSA Executive Director shall determine the playing date.
  5. Termination of the game due to weather, unplayable conditions, or mechanical malfunctions:
    - (a) The umpires may halt play for up to two (2) hours when conditions do not allow play to continue.
      1. The two-hour interruption(s) is cumulative
      2. The game must be terminated when the two-hour time period has elapsed. If the first game of a doubleheader is terminated, the second game will be postponed.
      3. The two-hour period does not include time needed to prepare the field for the resumption of play.
    - (b) Umpires must wait for at least 30 minutes before terminating a game for unplayable field conditions.
  6. In any softball game, if a team does not show up within 30 minutes of the scheduled game time, a forfeit shall be declared unless the delay is unavoidable and the visiting team notifies the home team. In emergency situations, the game may be started late, or may be rescheduled.
  7. In order to be used, the **tie-breaker procedure** shall be agreed upon by both teams during the pregame meeting with the umpires. If implemented, the procedure shall begin in the 10th inning (and any subsequent half-inning). Exception: In Invitational Tournament games with a "time limit" policy, the tie-breaker procedure would start in the subsequent inning after time had expired. If not agreed upon, games may end in a tie after seven (7) full innings, or after time had expired during invitational tournament games.
  8. Only game-essential personnel are permitted within the confines of the team's dugout and shall be held to the same level of accountability as the coaching staff and players.
  9. Sub-varsity games may have a time limit instead of playing seven innings as long as the guidelines are agreed upon before the start of the game.
  10. Varsity games played in invitational tournaments may have time limits as follows:
    - (a) No game may be less than five innings regardless of the time limit (4.5 innings if home team is ahead.)
    - (b) No time limit may be less than 90 minutes.
  11. Same-day multiple games, using the same umpires, shall receive the doubleheader game fee listed in the Appendix "F" Game Fee Chart.
  12. Host schools are required to post the current USA SOFTBALL list of "Non-Approved" bats in both dugouts during GHSA sanctioned games.

- G. Teams may have **spring try-outs** that are limited to a maximum of five consecutive school days between May 1 and the last day students are in school. Students must be academically eligible and enrolled at the school they are trying out for, or be an 8th grader at a feeder school for that school. Students currently in the 7th grade (rising 8th graders) may not participate in spring tryouts.
- H. Schools must enter team schedules, rosters and weekly game/meet results during the season on MaxPreps and be responsible for updates as needed. This information will support statewide media, event programs, broadcasts partners and GHSA Region Standings. Teams are encouraged to maintain team/individual statistics on MaxPreps.

#### **FAST PITCH REGION TOURNAMENTS:**

- A. The dates, times and sites will be determined by each Region and must be submitted to the Region Secretary.
- B. Each Region in All Classes will determine its top four (4) teams advancing to the Super Regionals no later than October 12, 2023, with the top four teams advancing to the First Round of the state playoffs. Teams advancing to the Super Regionals must be submitted in the MIS system no later than 9:00 a.m., on October 13, 2023.
- C. Region post-season games (play-in games, sub-region games, region tournament games) must have a minimum of two (2) games played on each field, each day, with the exception of a championship game.

#### **FAST PITCH STATE TOURNAMENT:**

- A. The first two rounds of the State Tournament will be played as a "Super Regional."
  - 1. The No. 1 seed in each 4-team pod in the bracket will host a double-elimination tournament in according to the seeding on the official GHSA playoff brackets.
    - (a) Classes A (Div. 2), 3A, 5A & 7A play their Super Regionals on Oct. 16-17.
    - (b) Classes A (Div. 1), 2A, 4A & 6A play their Super Regionals on Oct. 18-19.
  - 2. The higher-seeded team in each Super Regional game will be the designated "home" team.
  - 3. One team will advance from each Super Regional to a pre-designated placement in the Elite Eight bracket in Columbus, Georgia (see Appendix B).
- B. The Elite Eight of the State Tournament will be a double-elimination tournament held in Columbus, Georgia on October 25-28, 2023.
- C. **FINANCES:**
  - 1. Admission for the Super Regional events is \$12.00 per day or \$20.00 for a two-day pass. Admission for the Elite Eight is as follows:
    - (a) Single day admission is \$15.00.
    - (b) Four-day admission is \$45.00.**NOTE:** All Super Regional and Elite Eight admission fees **MUST** be purchased through GoFan.
  - 2. The GHSA will receive 12% of the gross gate receipts at all state playoff games. If schools are not able to cover the required costs with gate receipts, this fee will be waived if validated by the GHSA office.
  - 3. In the Super Regionals, the umpires will be paid out of gross receipts (**Note:** If the gross receipts are not sufficient to pay the umpires, the host school will pay that cost.)
  - 4. The visiting teams shall be paid \$.80 per mile (one way) for travel.
  - 5. During the Super Regionals and Elite Eight, each team is allowed **free admission** for a maximum of 25 players and team essential personnel. Schools desiring more than this number must pay the admission price or submit names on the "Excess Team Entry Form." Coaches will be admitted with their GHSA coaching passes.
  - 6. During the Super Regions, teams are responsible for their own travel and housing expenses, but housing will be arranged by the Columbus Sports Council for the Elite Eight Tournament in Columbus.
- D. All umpires will be assigned by the GHSA.
- E. Times posted with the brackets are approximate. Teams should be ready to take the field for play at the time indicated for each game.
  - 1. The top team in each bracket uses the first base dugout unless a team is playing consecutive games on the same field.
  - 2. The home team will be determined for each game with a coin toss.
  - 3. Lineups should be submitted to the official scorer at least 15 minutes prior to the scheduled starting time.
  - 4. Teams may not use game fields for batting practice.
  - 5. All teams advancing to the Elite Eight of the State Tournament are required to be present and in uniform at the Opening Ceremonies. Failure to comply with result in a \$250.00 fine to the school.



- F. The outfield fence will be set at 200' from home plate for the State Tournament in Columbus.
- G. All teams advancing to the Championship Finals shall be required to have all team bats inspected upon check-in at the championship venue.
  - 1. Bats that pass inspection will have an approved sticker placed on the bat.
  - 2. Bats that do not pass inspection will be confiscated and returned to the team at the conclusion of that team's final game.
  - 3. Bats found to be used in a game that do not have the approved sticker shall be confiscated and the offending player and head coach shall be restricted to the dugout for that game.

### SLOW PITCH SOFTBALL

- A. Slow Pitch softball is a state championship event organized on an Area basis in one classification with eight (8) Areas (depending on the number of schools participating). It will be played in the Spring each year.
- B. The maximum number of games allowed (not including state tournament games) shall be sixteen (16).
  - 1. Teams shall play not less than (2) two games each playing date.
  - 2. Games played in an Area Tournament count in the total games allowed (16).
  - 3. Beginning and ending dates are listed in the front of this publication.
- C. Area assignments will be made by the GHSA Executive Director each year.
- D. Schools intending to participate in Slow Pitch must notify the GHSA Office no later than March 1 each year.
- E. All games will be played by the rules published by The National Federation of State High School Associations, with the following GHSA State adoption exceptions: The distance from home plate to the nearest obstruction (fence) in fair ground shall be not less than 200 feet; the distance between bases shall be 65 feet; the pitching distance shall be 46 feet; and the ball shall be 12-inch/.47cor/375 compression.

### SLOW PITCH STATE TOURNAMENT

- A. Each Area will be responsible for determining the two (2) teams advancing to the state tournament. Teams advancing must be submitted to the GHSA Office no later than April 6, 2024 at 9:00 a.m.
- B. Teams advancing to the state tournament shall play in a double-elimination Sectional Tournament on April 10, 2024 at two (2) sites determined by the GHSA Executive Director. The top four (4) finishers at each Sectional Tournament shall advance to the Elite Eight at a site determined by the Executive Director.
- C. The Elite Eight of the State Tournament will be a double-elimination tournament held at a "neutral" site on April 17-18, 2024.
- D. The admission price for the Sectional Tournament and the Elite Eight Tournament will be \$10 per day.

## SECTION 14 SWIMMING AND DIVING

### GENERAL INFORMATION:

- A. Swimming and Diving is a classified event with four (4) state championships (classes 6A and 7A, and the combined divisions of classes A-3A and 4A-5A).
  - 1. Boys and girls compete for separate championships in each class.
  - 2. Beginning and ending dates for practice and competition can be found at the front of this publication.
  - 3. The maximum number of contests for swimming is ten (10) exclusive of the state meet.
  - 4. For divers, the maximum number of dual meet competitions is as follows:
    - (a) Six-dive format: ten (10) competitions AND/OR
    - (b) Eleven-dive format: five (5) competitions
  - 5. It is permissible for coaches to use "split squads" during the regular season. However, the use of split squads will count as two (2) of that school's maximum allowed competitions.
- B. The National Federation Swimming Rules shall be the official rules for all GHSA competitions with the exception of any special regulations found in this section.

- C. In those school systems where facilities are limited and one coach is hired to coach more than one high school team, or coaches from several schools use the same facility, the gathering of these students for practice purposes will not violate GHSA regulations. Competitions between schools during these practice sessions must be avoided unless they are counted within the number of allowable contests.
- D. Each school with a participating student(s) must have a school representative present at all GHSA meets.
- E. Schools must enter team schedules, rosters and weekly game/meet results during the season on MaxPreps and be responsible for updates as needed. This information will support statewide media, event programs, broadcasts partners and GHSA Region Standings. Teams are encouraged to maintain team/individual statistics on MaxPreps.
- F. ORDER OF EVENTS: (boys events precede girls events)
- |                               |                              |
|-------------------------------|------------------------------|
| 1. 200-yard Medley Relay      | 7. 100-yard Freestyle        |
| 2. 200-yard Freestyle         | 8. 500-yard Freestyle        |
| 3. 200-yard Individual Medley | 9. 200-yard Freestyle Relay  |
| 4. 50-yard Freestyle          | 10. 100-yard Backstroke      |
| 5. 1 Meter Diving             | 11. 100-yard Breaststroke    |
| 6. 100-yard Butterfly         | 12. 400-yard Freestyle Relay |

#### STATE MEET (GENERAL INFORMATION):

- A. In order to participate in the State Swimming and Diving Meet:
1. A participant must qualify at a meet governed by National Federation and GHSA rules.
  2. Qualifying times are listed at the end of this section, and entry deadlines must be met.
  3. Proof of Performance (POP) for swimming events must be verified by two GHSA coaches who are in attendance at that meet.
  4. Participating schools will be required to pay \$25.00 per entrant.
    - (a) fees are payable to Atlanta Swimming.
    - (b) fees are due on the first day of swimming competition.
    - (c) Fees not paid within one week are subject to 100% late fee.
- B. All eligible relay swimmers must be listed on the entry form. It shall not count as an entry unless the competitor actually competes in the event. Any individual listed on the entry form may swim in the prelims, swim-offs, and/or finals provided he does not exceed the permitted entry limit for the meet.
- C. Qualifying standards for the State Meet will be established by the GHSA Executive Director.
- D. A coaches' meeting will be held at the site preceding both the diving competition and the swimming competition.
- E. Only the coaches/faculty members listed on the entry form will have access to the pool deck.
- F. Rules and Restrictions for Meet Entries:
1. A school may enter only one (1) relay team per event.
  2. A school may not have more than four (4) entries in an event in which the contestants compete as individuals.
  3. A contestant may enter a maximum of four (4) events, no more than two (2) of which are individual events.
- G. No team points will be allowed to a swimmer or relay team if the qualifying standard for that event is not met or bettered in either the prelims or the finals. No team points will be awarded to divers if they do not equal or better the qualifying point total for six (6) dives.
- H. Reservation of seating space for spectators is not allowed.
- I. The **State Diving Championships** will be held Westminster High School, while the **State Swimming Championships** will be held at the Campus Recreation Center on the campus of the Georgia Institute of Technology on dates listed in the Beginning and Ending Dates Chart found at the front of this publication. The schedule for competition will be published on the GHSA web site ([www.ghsa.net](http://www.ghsa.net)).
- J. Team championships will be determined by scoring twenty (20) places as noted in the National Federation Swimming Rule Book. The top ten (1-10) qualifiers will compete in the championship heat, and the next ten (11-20) will compete in consolation heat "B."

- K. The lead-off 50-yard Freestyle split in the 200-yard Freestyle Relay, and the lead-off 100-yard Freestyle split in the 400-yard Freestyle Relay will be considered for State records in their respective events. NOTE: If the relay team is disqualified for any reason, the lead-off time will not count for qualifying or for a state record.
- L. Admission fee for the GHSA State Swimming and Diving Championship is \$15.00 per day.
- M. Free admission will be allowed for the following: 1. Swimmers and divers qualified and entered in the State Meet; 2. Coaches that are listed on the Swimming and Diving Coaches list; 3. Four girls and four boys designated as substitutes by the coach on the team list; 4. Two team attendants or trainers as listed on the team roster; 5. Those normally allowed free admission, such as with GHSA passes, will continue to be admitted by signing the pass list.

#### **STATE MEET (ELIGIBILITY/PROCEDURES):**

#### **DIVING**

- A. A diver may become eligible for the State Meet using a 6-dive sheet or an 11-dive sheet.
  - 1) **6-DIVE FORMAT:** This format is slightly different than the normal 6-dive dual meet format as defined in the NFHS Rules Book. If the 6-dive format is utilized and submitted, the first dive will continue to be from the group as specified by the NFHS and in the NFHS Rules Book. The first dive will maintain its assigned degree of difficulty, unless it is more than 1.8, in which case it will receive no more than 1.8 degree of difficulty. Dives 2-6 shall be one dive from each of the five (5) groups (forward, backward, reverse, inward, and twisting). The degree of difficulty of dives 1-6 when totaled shall be equal to or greater than 11.5 for girls and 12.0 for boys. The score to be achieved must be 190 points or more for both boys and girls.
  - 2) **11-DIVE FORMAT:** If the 11-dive format is utilized and submitted, it shall be on the official 11-dive sheet. For girls, the minimum degree of difficulty for optional dives shall be 11.5 when totaled, and the score to be achieved must be 300 points or greater. For boys, the minimum degree of difficulty for optional dives shall be 12.0 when totaled, and the score to be achieved must be 300 points or greater. NOTE: The official 11-dive Checklist as well as the 6-Dive and 11-Dive Forms can be found on the GHSA web site ([www.ghsa.net](http://www.ghsa.net)).
- B. In both the 6-dive and 11-dive formats, the meet must be scored by at least, but not limited to, three (3) judges. The official dive sheet that is submitted must be completed with all necessary signatures and information provided, such as phone, and e-mail information for the coach and diver, within one (1) week of the performance.
- C. **Proof of Performance:**
  - 1) Only one Proof of Performance (POP) dive sheet per diver may be submitted by uploading it onto the GHSA web site ([www.ghsa.net](http://www.ghsa.net)). The deadline date for submission may be found on a chart later in this section.
  - 2) If the diver's POP is accepted and approved, the coach will be notified at the email address provided when uploading the sheet. If the POP dive sheet is in any way incorrect, the coach will be notified and one (1) additional POP may be submitted, if desired.
  - 3) Dive sheets with electronically generated scores will not be accepted unless submitted from [www.DiveMeets.com](http://www.DiveMeets.com).
- D. **State Meet Dive Sheets:**
  - 1) The format and criteria required for the state dive sheet is slightly different than that listed in Section 4 - Choice of Dives that is detailed in the current NFHS Rules Book for championship meets. Divers will compete in a 6-Dive meet format at the State Championship meet with the following requirements:
    - (a) One (1) voluntary dive of the diver's choice with a maximum degree of difficulty of 1.8 followed by five (5) optional dives, one from each of the five (5) groups. The degree of difficulty of dives 1-6 when totaled shall be equal to or greater than 11.5 for girls and 12.0 for boys. The minimum score total to be achieved to earn points for the team must be 190 points or more after six (6) dives for both boys and girls.
    - (b) The 10 highest-scoring finishers from the preliminary event will move on to the finals and perform their six (6) dives again. Divers will be permitted to change dives, not dive order, for the finals so long as all sheet requirements are met.
    - (c) Scores from the preliminaries and finals will be cumulative.
  - 2) A diver will be automatically entered in the State Meet upon submission of the actual dive sheet on [www.DiveMeets.com](http://www.DiveMeets.com) by the deadline and approval of the dive sheet by the GHSA.
  - 3) The deadline for changing a dive sheet may be found on a chart later in this section.
- E. If a school has more than four (4) divers per gender that have been deemed eligible after official approval of the POP dive sheet, the school may submit a maximum of four (4) and only four (4) dive sheets per gender by the deadline.
- F. The Meet Director for the State Diving Meet will have jurisdiction over the method of announcing the diving.

- G. If possible, the championship venue(s) shall provide two (2) hours of practice time to State Meet participants the week of the State Meet.
- H. Boys will dive first in the odd-numbered years, and girls will dive first in the even-numbered years.
- I. For questions or concerns about State Meet eligibility and procedures, contact the State Diving Coordinator, Vicky Sanchez Tuymer, (vtuymer@hotmail.com).
- J. **The diving information found on the GHSA web site supersedes all other sources of information.**

**SWIMMING:**

- A. Coaches shall submit all Proof of Performances on the Georgia High School Swimming Coaches Association (GHSSCA) web site found at [www.ghssca.com](http://www.ghssca.com). All eligible relay swimmers must be listed on the site. It shall not count as an entry unless the swimmer actually competes in the event. Detailed submission instructions are also available on the site. At the end of the dual meet season, the web site will be closed to accepting new submissions and time will be given for coaches to make their final entry decisions. The coach must make the actual entry for the swimmer to compete in the State Meet on the GHSSCA web site by 11:59 p.m., Thursday, Feb. 1, 2024.
- B. Qualifying times and Deadlines are as follows:

| <b>BOYS</b> | <b>EVENT</b>               | <b>GIRLS</b> | <b>DEADLINES:</b> | <b>SUBJECT</b>                | <b>DATE / TIME</b>             |
|-------------|----------------------------|--------------|-------------------|-------------------------------|--------------------------------|
| 1:51.00     | 200 yard Medley Relay      | 2:07.00      |                   | Dive - POP                    | Within 1 week of performance   |
| 1:55.00     | 200 yard Freestyle         | 2:07.00      |                   | Swim - POP                    | Within 1 week of performance   |
| 2:12.00     | 200 yard Individual Medley | 2:24.00      |                   | Dive - Last POP               | Thursday, February 1, 11:00 pm |
| 23.50       | 50 yard Freestyle          | 26.50        |                   | Swim - Last POP               | Thursday, February 1, 11:00 pm |
| 58.00       | 100 yard Butterfly         | 1:05.00      |                   | Dive - Dive sheet for State   | Saturday, February 3, 4:00 pm  |
| 52.00       | 100 yard Freestyle         | 58.50        |                   | Swim - Actual meet entry      | Thursday, February 1, 11:59 pm |
| 5:20.00     | 500 yard Freestyle         | 5:40.00      |                   | Dive - Changes on State sheet | Saturday, February 3, 4:00 pm  |
| 1:40.00     | 200 yard Freestyle Relay   | 1:53.00      |                   |                               |                                |
| 1:00.00     | 100 yard Backstroke        | 1:06.00      |                   |                               |                                |
| 1:07.00     | 100 yard Breaststroke      | 1:15.00      |                   |                               |                                |
| 3:44.00     | 400 yard Freestyle Relay   | 4:12.00      |                   |                               |                                |

**SECTION 15  
TENNIS**

**GENERAL INFORMATION:**

- A. Tennis is a team state championship sport for boys and girls that is based on Region play in all classifications. Beginning and ending dates for practice and competition can be found at the front of this publication.
- B. All tennis matches will be played according to tennis rules published by the U.S. Tennis Association (USTA) unless otherwise specified by the Georgia High School Association.
  - 1. The rules of the USTA Handbook relating to lateness for a match will apply to GHSA matches.
  - 2. There will be continuous play except that a GHSA certified coach from that school may talk to their player(s) as they change ends of the court after a game, but the player(s) must stay on the court.
  - 3. In regular season play and in the Region tournament, the 8-game Pro Set format is allowed if both coaches are in agreement. 8-Game Pro Set: First player to win 8 games by a margin of 2 games (ie, 8-5, 8-6, 9-7) wins the set - if score gets to 8-8, the tie-breaker as outlined in this section is used.
  - 4. Any GHSA tennis match that is interrupted, such as by weather or darkness, and can not be completed that day should be resumed (if it is to be made up) from the exact point of interruption at a future date agreed upon by the competing schools.
- C. Teams are restricted to no more than eighteen (18) varsity play dates excluding Region and State tournaments. The 18 play dates are for the complete team (singles and doubles). There will be no singles tournaments allowed.
  - 1. Each play date of an invitational tournament counts toward the maximum of 18 play dates.
  - 2. No school shall enter any invitational tournament unless it has been approved by the GHSA Executive Director.
  - 3. It is permissible for coaches to use "split squads" during the regular season. However, the use of split squads will count as two (2) of that school's maximum allowed play dates.
  - 4. There shall be no interscholastic practices and/or scrimmages.
- D. The format for all GHSA tennis matches during the regular season, region tournaments and state playoffs shall be three (3) singles matches and two (2) doubles matches played on composition (hard) surfaces unless the competing

schools agree to play on a non-composition surface prior to the match. With prior agreement of both coaches, JV squads may use a format of two (2) singles matches and one (1) doubles match. NOTE: No GHSA match at any level may be played where there are fewer than three (3) points available and any pre-match forfeitures must take place at the lowest level. No. 1 singles and No. 1 doubles may never be forfeited before a match begins.

1. An individual player may play in either one (1) singles match or one (1) doubles match ONLY.
  2. Substitution is not permitted once a match is engaged under USTA definition. If any injury occurs during play that prevents a player from completing the match, that player defaults and the opponent is awarded the victory.
  3. Teams have the option to play a 10-point tiebreaker (see USTA rules for playing process) in lieu of a full third set during the regular-season and Region tournament by agreement of the two coaches during the regular-season and by a majority vote of the Region coaches in the Region tournament. Note: All State Playoff matches must be best of three full sets.
  4. Teams may play up to three (3) matches in a day IF a 10-point tiebreaker is used in lieu of a full third set in all three matches.
- E. 7-Point Tie-Breaker for Singles (Team A vs B)
1. This is used when the score is tied 6-6 (or 8-8 in Pro-Set) in any set (1st, 2nd, or 3rd).
  2. Player A serves the first point from the right service area.
  3. Player B serves the second and third points from the left and right service areas respectively.
  4. Player A serves the fourth and fifth points - again alternating the service areas.
  5. Player B serves the next two points and ends of the court are changed between these two points.
  6. Player A serves the eighth and ninth points.
  7. After this, the serve is alternated on every two points.
  8. If the tie-breaker ends with a 6-6 score, the players change ends of the court and alternate serves until one player is ahead by two (2) points - which gives that player a set victory of 7-6.
  9. Players switch ends of the court after every six (6) points and at the end of the tie-breaker.
- F. 7-Point Tie-Breaker for Doubles (Team A & B vs C & D)
1. Player A serves the first point from the right service area.
  2. Player C serves the second and third points - alternating the service areas.
  3. Player B serves the fourth and fifth points.
  4. Player D serves the sixth and seventh points, and ends of the court are changed between the points.
  5. After this, play continues with the same service rotation until one team has either won seven (7) of the first twelve (12) points, or a team established a two-point margin after twelve (12) points have been played.
  6. Teams change ends of court after every six (6) points and at the end of the tie-breaker.
- G. Schools must enter team schedules, rosters and weekly game/meet results during the season on MaxPreps and be responsible for updates as needed. This information will support statewide media, event programs, broadcasts partners and GHSA Region Standings. Teams are encouraged to maintain team/individual statistics on MaxPreps.

#### REGION COMPETITION:

- A. Each Region will determine how it will choose its top four (4) teams.
1. The top 4 Region representatives shall be determined no later than April 11, 2024.
  2. The top four Region teams must be submitted to the GHSA no later than 9:00 a.m., on April 12, 2024.
  3. Five percent (5%) of the gross gate receipts (if admission is charged) will be sent to the GHSA, and then the Region will decide how to handle expenses and disbursements.
- B. At the end of the regular season and **prior to any post-season play**, each coach will submit to the Region tournament director and enter **electronically** on the GHSA MIS web site an **official playoff roster** listing the singles players as Nos. 1, 2, and 3 and the doubles teams as Nos. 1 and 2, **in proper order of ability** (based on the integrity of the coach). This roster will be the lineup used in ALL tournament play thereafter, unless an alternate is used under the restrictions listed below. NOTE: If no Region tournament is held, the **official playoff roster** must be entered **electronically** at the end of the regular season and prior to the start of the state tournament.
1. Stacking of one's lineup is strictly prohibited in any regular-season match, invitational tournament or state tournament match. An obvious attempt to stack a lineup (i.e., use a player or doubles team below their relative ability level on the team) may result in the immediate disqualification of the entire team.
    - (a) For each regular-season match, the coach will choose three players (A, B & C) to play singles and two pairs of players (D1 & D2) to play doubles that day. The best player of A, B and C must play the No. 1 position in singles and the weakest must play No. 3 singles. The best doubles team of D1 and D2 must play No. 1 doubles (Note: Points may only be forfeited beginning with the lower positions and working upward unless an injury or illness occurs after a match has begun).
    - (b) It is not stacking to alternate from match to match during the regular season the positions of A and B, B and C, and even A and C if the players are of relatively equal ability. Likewise, D1 and D2 could alternate if these teams are of relatively equal ability.

- (c) It is not stacking if players alternate from singles to doubles, and vice versa, from match to match during the regular season as long as the singles players being used that day are listed from No. 1 to No. 3 according to relative ability, and the best doubles team being used that day plays at No. 1 doubles.
2. Designate up to six (6) **alternates** on the **official playoff roster** to be used under the following conditions:
  - (a) Alternates should not be better in ability than ANY of the players listed on the playoff roster in the positions of Nos. 1, 2, or 3 singles OR Nos. 1 or 2 doubles.
  - (b) Alternates may be used in either singles or doubles competitions, but the same player may not be used for both in the same round of competition.
  - (c) **Substitutions** made after the official playoff roster has been submitted must be made at the lowest level of singles play with all others moving to the higher level of competition. In doubles competition, the coach has the option to place the alternate in the open slot or to place the alternate on the No. 2 doubles team and move a player from the No. 2 doubles team to the No. 1 doubles team, if the original vacancy is on the No. 1 team. A player may never be used in a position lower than his original position. NOTE: A substitution violation results in the loss of that line and not the forfeiture of the entire team match.
  - (d) If the original contestant(s) resumes play, everyone moves back to their original positions listed on the submitted playoff roster.
  - (e) A player listed as a singles player on the **official playoff roster** shall not switch over to doubles competitions in any later round, or vice-versa.
3. A serious injury, illness, suspension or other conflict MAY warrant a waiver of the anti-stacking restrictions listed above. Such waivers will be considered on a case-by-case basis upon receipt of proper documentation to the GHSA office, including a letter signed by the school's principal.
4. A school objecting to an opponent's lineup **must provide documentation** (newspaper articles, scorebooks, and written confirmation from other coaches) of any stacking violations.

#### STATE TOURNAMENT:

- A. The State Tournament is considered a continuation of the Region Tournament.
  1. Tournaments will be held for both boys teams and girls teams in each classification.
  2. Trophies shall be presented to the champions and runners-up in each classification - both boys and girls.
  3. In order to host a State Tournament match beyond the region level, the host school must have available a minimum of two (2) courts. Four (4) courts is preferable.
  4. The **First Four (4) Rounds** of the State Tournament will take place on the "home" courts of the higher seeded teams with the following schedule: The **First Round** must be completed **no later than** April 18, 2024; the **Second Round** must be completed no later than April 24, 2024; the **Quarterfinal Round** must be completed no later than April 30, 2024; and the **Semifinal Round** must be completed no later than May 6, 2024. If the teams are equal seeds, a "universal" GHSA coin flip will determine the host school.
  5. In each round of the state playoffs, the following will apply:
    - (a) Coaches will contact each other and set up a **mutually** agreeable time and date.
    - (b) If an agreement on time and date cannot be reached, the Executive Director will set the time and date.
    - (c) In situations where fewer than five (5) courts are available per team match, the order of play **must** be as follows: No. 1 singles, No. 1 doubles, No. 2 singles, No. 2 doubles, No. 3 singles.
    - (d) The **home team** is responsible for reporting the winners and scores to the GHSA office by 9:00 a.m., the day after the match.
  6. The **State Finals** will be held for both boys and girls in all classifications at the Rome Tennis Center at Berry College on the date indicated in the Beginning and Ending Dates table in the front of this publication. The exact schedule will be posted on the GHSA web site prior to the tournament.
- B. All team matches shall be the best three of five (3 singles/2 doubles) matches, using the 7-point tie-breaker.
  1. A team winning three (3) of the five matches (3 singles/2 doubles) shall be the winner.
  2. A team match is concluded as soon as three (3) points have been won, unless both coaches agree to finish all five lines.
- C. Each team shall furnish five (5) cans of high-quality, heavy-duty tennis balls through the **Semifinal Round**.
  1. New balls will be used in the first team match.
  2. After the team match, the losing team will keep the balls used in that match, and the winning team takes the unopened cans of balls to the next round of competition.
  3. At the **State Finals**, the GHSA will supply the tennis balls.
- D. For all rounds of the state playoffs prior to the finals, the host school shall provide a designated "**site manager**" to make rulings concerning sportsmanship, lateness, or other rules violations that might occur during the match. This person should be a certified USTA official when possible, hired and paid for by the host school. In instances where a USTA official cannot be secured, a school administrator **must** be the replacement. For the finals, the GHSA will provide the site manager.

**SECTION 16  
TRACK AND FIELD**

**GENERAL INFORMATION:**

- A. Track and Field is a team championship event for boys and girls that is based on Region competition in all classes. Beginning and ending dates for practice and competition can be found at the front of this publication.
- B. All GHSA Track meets will be run in accordance with the rules published in the National Federation Track and Field and Cross Country Rule Book with any exceptions and/or adoptions noted in this section. (NOTE: Knowledge of and compliance to all exceptions is the responsibility of the head coach.)
- C. Track meet requirements:
1. There will be no interscholastic practices or exhibition meets in Track.
  2. The maximum number of meets that may be scheduled is twelve (12), but no individual student may compete in more than ten (10) meets (excluding the Region, Sectional and State Meets).
  3. Track teams may compete in one (1) indoor meet, and this meet will not count as a part of the ten (10) meets allowed per athlete provided the meet is after the date for practice to begin and prior to the date to begin regular competition.
  4. It is permissible for coaches to use "split squads" during the regular season. However, the use of split squads will count as two (2) of that school's maximum allowed competitions.
- D. Any meet involving eight (8) or more schools must be approved by the GHSA Executive Director in accordance with the process described in By-Law 2.64.
- E. A competitor **shall not compete in more than four (4) events**, including relays. Contestants officially become competitors when they report to the clerk of the course or field-event judge for an event in which they are entered. A contestant shall not be entered in more than four events, excluding relays. If a contestant is entered in more than the allowable number of events, meet management shall scratch the contestant from the excess event(s) by following the listed Order of Events.  
A contestant may officially participate in:
1. Four individual events - NO Relay events.
  2. Three individual events - May be listed on any number of relay events but **compete** in only one relay event.
  3. Two individual events - May be listed on any number of relay events but **compete** in only two relay events.
  4. One individual event - May be listed on any number of relay events but **compete** in only three relay events.
  5. NO individual events - May be listed on any number of relay events and **compete** in all four relay events.
- F. The following regulations apply to the Pole Vault event:
1. All GHSA schools competing in the pole vault event must meet the minimum NFHS regulations on the vaulting area, the plant box, the vault box collar, the vaulting standards and padding, the crossbar and the landing pads and padding on any hard surfaces. Schools not able to meet these regulations are not allowed to practice or compete in the pole vault event at the non-complying site.
  2. *Those schools wishing to host a pole vault competition must file annually the "Pole Vault Facility Certification" form found on the GHSA MIS site. A listing of approved schools will then automatically post to the GHSA web site.*
  3. In compliance with NFHS rules, school administrators and coaches must verify that all vaulters and poles meet event requirements. A "Pole Vault Verification Form" (found on the GHSA web site) is to be submitted before each competition.
- G. The GHSA has elected to fully comply with the NFHS Rule 4-3-1. All competitors shall have legal uniforms. The singlet and bottom, or one-piece uniform, must be a school-issued or school-approved Track and Field uniform. Uniform bottoms clearly designed as "underwear" will NOT meet the NFHS or GHSA requirement. Uniform tops and one-piece uniforms with multiple manufacturer logos are NOT legal. Uniform bottoms with logos completely around the waistband are LEGAL. Team uniforms worn must clearly identify the competitors, at a glance, as being a member of a certain team. (CLARIFICATION: Team members competing in individual events must wear clearly identifying uniforms for that team, but NOT NECESSARILY of the same design. Relay team members on the same team must wear uniforms of the same design. NOTE: The ultimate responsibility for uniforms compliance lies with the coach. Coaches should inspect any/all garments competitors wear to make sure they are in compliance with GHSA and NFHS uniforms rules.
- H. Electronic devices, including but not limited to disc players, tape players, cell phones, pagers, walkie talkies, are permitted for use by coaches within designated coaching boxes or outside of restricted competition areas.

- I. In the **Region** and **State** meets, eight (8) places shall be scored, with point totals counting as follows:
- |               |   |           |              |   |          |
|---------------|---|-----------|--------------|---|----------|
| First Place   | = | 10 points | Second Place | = | 8 points |
| Third place   | = | 6 points  | Fourth Place | = | 5 points |
| Fifth Place   | = | 4 points  | Sixth Place  | = | 3 points |
| Seventh Place | = | 2 points  | Eighth Place | = | 1 point  |
- NOTE: When there is a tie, the points will be divided equally among the contestants who are tied.

**REGION COMPETITION:**

- A. Deadlines for posting the Region list of entries will be a Region decision.
- All entries must be made on MileSplit GA.
  - Posting entries on sites other than MileSplit GA does **NOT** fulfill the GHSA requirement for electronic submission.
  - Coaches may alter the list of entries until the deadline established by each Region for their Region Meet.
  - All Region Secretaries should communicate their deadline for entries before the "Scratch Meeting" that precedes the Region Meet.
- B. The time schedule for the Region Meet shall be given to each competing school prior to the start of the Meet.
- Events to be contested for Boys and Girls Track (18 events):
 

| <u>RUNNING EVENTS</u>                            | <u>FIELD EVENTS</u>                                     |
|--|---|
| 4x800m Relay                                     | Discus (Girls 2.20 lb./1kg.) (Boys 3.53 lb./1.6 kg.)    |
| Girls 100m Hurdles (33")/Boys 110m Hurdles (39") | High Jump   |
| 100m Dash  | Long Jump   |
| 4x200m Relay                                     | Pole Vault  |
| 1600m Run  | Shot Put (Girls 8.81 lb./4 kg.) (Boys 12 lb./5.443 kg.) |
| 4x100m Relay                                     | Triple Jump   |
| 400m Dash  |   |
| 300m Hurdles (Girls 30" / Boys 36")              |   |
| 800m Run   |   |
| 200m Dash  |   |
| 3200m Run  |   |
| 4x400m Relay                                     |   |
  - Each school may have three (3) entries in each individual event and one (1) entry in each relay event.
  - Relay teams entered in the Region Meet may list a maximum of eight (8) runners.
    - The relay names remain the SAME throughout the State Meet Series (Region/Sectional/State Meets) and are the **ONLY** eligible participants for qualifying relay teams throughout the State Meet Series.
    - NO** replacements may be made in the Relay list of runners advancing from the Region Meet to the Sectional Meet to the State Meet.
    - Any four (4) competitors listed on a Region Meet relay event entry may run in that event in any round of advancement (Region, Sectionals, State Meet Semifinals and Finals), and in any order desired.
  - In Shot Put, Discus, Long Jump, and Triple Jump, the giving of qualifying and final trials is optional. NOTE: The Region Games Committee may institute a process in which each contestant has three (3) attempts and only the best attempt counts.
  - It is recommended that all Regions conduct the boys and girls competitions on the same dates in order to comply with the GHSA deadline for completion of Region track competitions.
- C. When there is a tie in any event involving more contestants than the Region is entitled to enter in the Sectional or State Meet, the contest must continue or be re-held until the representatives to the Sectional or State Meet are determined, and no points be given for the continued or re-held contest. For possible replacement purposes, all field events must determine clear 5th and 6th place finishers in **ALL** Classes.

**SECTIONAL COMPETITION:**

- A. Basic Information
- The top four (4) finishers in each event from each Region Meet will advance to a Sectional Meet.
  - Boys and Girls Sectionals in each classification will take place on the same date at the same site (see schedule of Sectionals on the GHSA web site).
  - For Running Events, there will be qualifying heats only - no running finals will be held.
    - There will be two heats in each event, excluding the 1,600 and 3,200 Meter Runs and the 4x800 Meter Relay. The first place finisher in each heat and the next six (6) fastest times from either heat will advance to the State Final.



- (b) For the 1,600 Meter and 3,200 Meter Runs and 4x800 Meter Relay, there will be one heat and the top eight (8) finishers in each race will advance to the State Final.
  4. For Field Events, prelims and finals will be held in all events with the top eight (8) finishers advancing to the State Final.
  5. For replacement purposes, ALL events must determine clear 9th and 10th place finishers.
  6. Relay teams *competing at the Sectional Meet must have been listed on the initial roster.*
    - (a) NO replacements may be made in the Relay list of runners advancing from the Sectional Meet to the State Final.
    - (b) Any four (4) competitors listed on a Sectional Meet relay event entry may run in that event in any round of advancement (Sectionals, State Meet Semifinals and Finals), and in any order desired.
- B. Sectionals will be conducted one (1) week prior to the earliest State Final.
- C. All replacements from the Region meets for the Sectionals must be made on MileSplit GA. The **REGION SECRETARY** or the Region Meet Director may make confirmed changes and/or corrections. The deadline for all changes is 12:00 noon on Wednesday, May 1, 2024.
- D. A listing of Sectional Sites may be found on the track page of the GHSA web site ([www.ghsa.net](http://www.ghsa.net)).

#### STATE CHAMPIONSHIP MEETS:

- A. The State Championship Meets will be held on the dates listed in the Beginning and Ending Dates table at the front of this publication. Exact sites and schedules will be posted on the GHSA web site prior to the event.
1. If weather conditions alter the schedule, night sessions may be held or the schedule may be condensed to a one-day meet.
  2. Preliminaries may be eliminated and finals held in any of the events provided that notice is given prior to the beginning of the meet.
  3. In each preliminary running event (semifinals), there will be two (2) heats with the first place finishers in each heat and the next six (6) fastest times qualifying for the finals.
- B. The top finishers as described from each Sectional Meet will qualify for the State Final in ALL classes.
1. When a qualifier can not compete in the State Meet, the next competitor in the order of finish will be selected as a replacement.
  2. All replacements for the State Meet must be submitted on MileSplit GA. Only the **SECTIONAL MEET DIRECTOR** may make changes/corrections to the list of State Meet Qualifiers. The deadline for all changes is 12:00 noon on Tuesday, May 7, 2024.
  3. It is the responsibility of **EACH COACH** to review the school's entries on MileSplit GA and immediately notify the Sectional Meet Director if corrections need to be made.
- C. Each contestant is requested to bring his/her own shot and discus.
1. Any contestant may use any shot or discus after it has been checked for weight and legality at the field.
  2. Rings for the shot and discus are concrete; therefore, rubber soled shoes must be worn.
  3. The NFHS Track and Field Rule Book will be strictly enforced in regard to the time between jumps and throws.
- D. At the State Meets (boys and girls), 34.92-degree throwing sectors will be used (Discus: Rule 6-6-5; Shot Put: Rule 6-7-5). Schools, Region hosts and Sectionals hosts **must** have the 34.92-degree sectors in place for the Region and Sectionals meets.
- E. The tracks and runways that are used for all State Meets are all-weather tracks.
1. Spikes on track shoes must not exceed the specified length(s) at each State Meet:  
NOTE: Shoes may be inspected before contestants are allowed on the track.
  2. Spikes that have been cut off by individuals must be filed to a sharp point. Blunt spikes will not be allowed.
  3. Only the starting blocks furnished at the track may be used in the State Meets.
- F. Admission price for each of the State Meets may be found on the GHSA web site.

#### ADAPTED DIVISION

##### WHEELCHAIR TRACK AND FIELD:

1. All high school students with a permanent, physical disability may be eligible to participate on their school's track and field team. These students will have the opportunity to compete in the 200 and 800 meter wheelchair races and the shot put. There will be two (2) divisions of competition in the shot put based upon the disability.

2. Students who participate must meet all GHSA eligibility requirements.
3. All athletes qualified for the Wheelchair competition must compete in either a standard wheelchair, a throwing chair or a specially designed racing chair.
4. Students will be members of the school's track and field team and may compete at all the school's meets (regardless of the number of wheelchair competitors), including Sectionals. The athletes must compete in their school's team uniform. The top eight (8) qualifiers over the entire track season in each event, including Sectionals, will advance to compete at the State Track Meet.
5. Wheelchair racers must use a racing wheelchair, gloves and a bicycle helmet that meets ANSI standards.
6. In the shot put, boys Class 1 will use an 8.81lb./4.0 kg. shot while boys Class 2 will use a 6 lb. shot. Girls in Classes 1 and 2 will use a 6 lb. shot.
7. Coaches must complete a required training course conducted by AAASP.
8. All times and distances are to be reported to [resultsga@adaptedsports.org](mailto:resultsga@adaptedsports.org) by the athletes' coaches.
9. For more information, contact AAASP at 404-294-0070 or see the AAASP web site [www.adaptedsports.org](http://www.adaptedsports.org).
10. Information about all Adapted Sports programs may be found on the [ghsa.net](http://ghsa.net) web site by entering this link: [ghsa.net/adapted-team-sports-information](http://ghsa.net/adapted-team-sports-information)

**AMBULATORY STUDENT-ATHLETES WITH DISABILITIES:**

1. An ambulatory student-athlete must have a permanent orthopedic, neuromuscular, visual, or other physical disability. Permanent orthopedic impairment and/or visual impairment shall be verified by a licensed physician and maintained on permanent file at the school.
2. All high school students with a permanent, physical disability may be eligible to participate on their school's track and field team.
3. Students who participate must meet all GHSA eligibility requirements. Students shall be members of the school's track and field team and shall have the opportunity to compete at the school's regular season meets (regardless of the number of adapted competitors). The athletes must compete in their school's team uniform.
4. **Divisions:** Two divisions: Male Female. **Events:** Track: 100, 200, 400; Field: Shot, Discus.
5. Students will be members of the school's track and field team and may compete at all the school's meets (regardless of the number of ambulatory competitors), including Sectionals. The athletes must compete in their school's team uniform. The top eight (8) qualifiers over the entire track season (including Sectionals) in each event will advance to compete at the State Track Meet and must meet standards listed below. Maximum number to qualify per class (division), per event shall not exceed the number of qualifiers allowed for able-bodied athletes - eight (8). Number of events allowed is five (5).
6. Ambulatory Division Qualification Standards:
 

| Event      | Boys | Girls |
|------------|------|-------|
| <b>100</b> | :25  | :30   |
| <b>200</b> | :55  | 1:10  |
| <b>400</b> | 2:00 | 2:10  |

**Shot Put:** Boys- 4M-4K; Girls- 4.4M-6lbs  
**Discus:** Boys- 19M-1.5K; Girls- 10M-1K
8. All times and distances are to be reported to [resultsga@adaptedsports.org](mailto:resultsga@adaptedsports.org) by athletes' coaches.
9. For more information, contact AAASP at 404-294-0070 or see the AAASP web site [www.adaptedsports.org](http://www.adaptedsports.org).

**SECTION 17  
VOLLEYBALL**

**REGULAR SEASON:**

- A. Volleyball is organized on a Region or Area basis with seven (7) state championships. Beginning and ending dates for practice and competition can be found at the front of this publication.
- B. The National Federation Volleyball rules committee has given each state its option about the number of games that determine a match.
  1. Region/Area matches shall be best-of-three unless ALL teams in the Region/Area agree (prior to the start of the season) to play best-of-five. Championship matches in the Region/Area Tournament **may** be best-of-five, and all post-season play after Region/Area Tournaments **shall** be best-of-five.
  2. In all competitions, the deciding set shall be played to fifteen (15) points.
- C. Notification of entry in Volleyball must be filed in writing with the GHSA State Office no later than March 1, for the next school year. Schools will be assigned by the GHSA Executive Director to a region or geographic area for competition, and then will be notified of that assignment.

- D. Schools must enter team schedules, rosters and weekly game/meet results during the season on MaxPreps and be responsible for updates as needed. This information will support statewide media, event programs, broadcasts partners and GHSA Region Standings. Teams are encouraged to maintain team/individual statistics on MaxPreps.
- E. Playing dates:
1. Schools have a maximum of 18 playing dates regardless of whether or not it is a tournament format or head-to-head competition (each day of a tournament equals one playing date). Region/Area and State playoffs are not counted as part of the allotted playing dates.
  2. An invitational tournament is defined as *five (5)* or more schools competing in a single or double elimination format that leads to a champion being declared. The use of pool play is acceptable.
  3. The maximum number of days for an invitational tournament is two (2) days.
  4. No school shall enter any tournament unless it has been approved by the GHSA Executive Director.
- F. MISCELLANEOUS INFORMATION:
1. In accordance with National Federation rules, the use of artificial noisemakers shall be prohibited.
  2. Display of signs (larger than 8.5 x 11 inches) in the stands is not allowed during regular season or post season competition.
  3. Competitors must stay in uniform while in the competitive area.
  4. All varsity Region/Area Volleyball matches shall be officiated by at least *two (2)* officially-dressed volleyball official who are registered under the GHSA plan for the registration of officials.
    - (a) *The host school must provide registered Line Judges (21 years old or older) who have completed the Line Judge Course at learn.ghsa.net at all Region/Area varsity matches.*
    - (b) *The host school must provide an adult (21 years old or older) to maintain the official scorebook and libero tracker sheet at all Region/Area varsity matches.*
  5. Each school will have a contract with an officials association for regular season matches, play days and invitational tournaments. The host school will be billed by the official's association for all of the officiating fees for these games, including travel.
  6. In accordance with National Federation rules, teams may use multi-colored balls in the regular season and post-season competitions.
  7. One coach (head or assistant) may stand in the libero replacement zone to coach his/her team during play.
  8. Schools may have **tryouts** that are limited to a maximum of five consecutive school days between May 1 and the last day students are in school. Students participating must be academically eligible and enrolled at that school or an 8th grader at a feeder school for that school.

#### REGION/AREA INFORMATION:

Each Region/Area may determine its procedure for selecting and ranking its top four (4) teams for the state playoffs. The Region/Area may use regular season records and not have a Region/Area Tournament. The Region/Area may choose to have either a single-elimination (best 3 of 5) or a double-elimination (best 2 of 3) tournament with schools seeded on the basis of their Region/Area records - or may allow schools to play a non-Region/Area schedule and then be seeded into the Region/Area Tournament. That choice must be submitted to the Region or GHSA Volleyball Area Coordinators before the first competition date of the regular season.

1. All finances (including officials' game fees and travel) will be the responsibility of the Region/Area.
2. Region ticket prices are set by the Region. Area ticket prices are to be set at \$6.00.
3. The GHSA will receive 5% of the gross gate receipts.
4. Results of each Region/Area Tournament must be entered in the GHSA MIS system within 24 hours of the completion of the event, but no later than 9:00 a.m., Monday immediately following the Region/Area Tournament.

#### STATE PLAYOFFS:

The **State** Volleyball playoffs will consist of five (5) rounds of dual matches. The first *three (3) rounds* will be held at the site of the higher-seeded team, with *the semifinals* and championships to be held at neutral sites. (NOTE: A GHSA "universal" coin flip will be held in the event same-seeded teams meet in any round.)

1. All playoff matches will be a best-of-five, single-elimination format *and played on:*
  - (a) *A full court that is free of overhead obstructions (including an overhead scoreboard).*
  - (b) *A court that is equitable in spacing on both sidelines and endlines.*
  - (c) *A court that is free of obstructions coming into play such as walls, bleachers, benches, etc.*
  - (d) *A court that provides adequate lighting.*
2. The seeding for the playoffs will be determined by a team's finish in region/area competition or tournament.
3. Finances for all classes **through the Quarterfinal Round** will be handled as follows:
  - (a) Admission fee for the First and Second Rounds is \$8.00 per day. Admission fee for the Quarterfinals is \$10.00.

- (b) The GHSA will receive 12% of the gross gate receipts.
  - (c) Officials' fees will be taken from the gross gate receipts and paid by the host school.
  - (d) The visiting team will be paid mileage at the GHSA-approved rate.
  - (e) Any residual funds will be split between the teams.
  - (f) The host school will be entitled to all concession funds.
4. Finances for the **Semifinal and Championship matches** shall be handled as follows:
- (a) Ticket prices are TBD and will be published on the GHSA web site.
  - (b) The gate receipts will be sent to the GHSA office.
    - 1. GHSA will retain 12% of the gross receipts.
    - 2. GHSA will pay the officials.
    - 3. Any funds remaining will be disbursed to the competing teams.
5. The number of **free admissions** for "traveling parties" of participating teams at playoff contests shall be a maximum of 20 players and team essential personnel. Coaches will be admitted with GHSA coaching passes.
6. Line Judges will be supplied by the various officials' associations for all post-season matches.
7. *Pep bands with a maximum of 15 members and one (1) adult school personnel member may be allowed. If the home team allows its pep band to attend, it shall also allow the visiting team's pep band to attend.*
8. *A maximum of sixteen (16) cheerleaders in uniform will be allowed.*

## SECTION 18 WRESTLING

### GENERAL INFORMATION:

- A. Wrestling will be a state open meet with separate competitions for classes A through 7A and Girls. Traditional wrestling teams will compete in Region/Area Tournaments (Classes A through 3A and Girls will be divided into eight (8) Areas each, while classes 4A through 7A will be divided into eight (8) Regions each), a State Traditional Tournament and the State Traditional Finals. There will also be separate competitions in Team Dual Wrestling. Beginning and ending dates for practice and competition can be found at the front of this publication.
- B. The National Federation Wrestling Rules shall be the official rules for Georgia schools with the exception of any special regulations found in this section.
- C. Notification of entry in Wrestling must be filed with the GHSA office no later than March 1 for the next school year. Schools in Classes A through 3A will be assigned to a geographic area by the GHSA Executive Director, and then will be notified of that assignment. Schools in Classes 4A through 7A will compete in their assigned Regions.
- D. Free Style and Greco Roman wrestling are considered to be the same sport as Folk Style (high school) wrestling and are subject to GHSA rules concerning illegal practices.
- E. A school may enter its wrestling team in competition for twenty (20) playing dates, not including post-season competition. A school may enter its girls wrestling team in competition for twenty (20) playing dates, not including post-season competition. Wrestling will become a Dual Gender sport for the 2023-24 school year. NOTE: After December 31, no new wrestling competitions may be scheduled unless approved by the GHSA Executive Director.
- 1. *An invitational tournament is defined as five (5) or more schools competing in a single or double elimination format that leads to a champion being declared. The use of pool play is acceptable.* The maximum number of days for an invitational tournament is two (2) dates.
  - 2. A student may not wrestle more than six (6) matches per day. *No student shall wrestle in more than 10 matches in a period of two consecutive days.* Forfeits do not count toward the match limit.
  - 3. Contestants must have *30 minutes rest* between matches.
  - 4. A wrestler may wrestle in both a varsity and a sub-varsity match on the same day as long as that wrestler does not exceed the maximum number of matches allowed for that day.
  - 5. It is permissible for coaches to use "split squads" during the regular season. However, the use of split squads will count as two (2) of that school's maximum allowed competitions.
  - 6. All girls vs. girls Dual and Traditional results should be entered into **TrackWrestling**.
- F. Beginning and ending dates for practice and competition can be found at the front of this publication.
- 1. A school shall not allow its team to engage in any interscholastic exhibition, practice, and/or scrimmage match, except for one (1) interscholastic scrimmage consisting of a Tri-match on a school night or a Quad-match on a non-school night format with officials registered with the GHSA.
  - 2. A practice shall involve only eligible students in the member school and their approved coaches. Participation by outside individuals constitutes an illegal practice.

3. Wrestling matches in practice must be conducted in adherence with National Federation and GHSA rules, and will involve only eligible team members.
4. Schools having contestants in the State Tournament may provide a teammate of comparable size to practice for the State Tournament.
5. There will be no Spring practice for Wrestling.

G. Weight classifications shall be as follows:

|          |          |          |          |
|----------|----------|----------|----------|
| 106 lbs. | 132 lbs. | 157 lbs. | 190 lbs. |
| 113 lbs. | 138 lbs. | 165 lbs. | 215 lbs. |
| 120 lbs. | 144 lbs. | 175 lbs. | 285 lbs. |
| 126 lbs. | 150 lbs. |          |          |

Girls weight classes when **girls are wrestling girls** shall be as follows:

|          |          |          |          |
|----------|----------|----------|----------|
| 100 lbs. | 120 lbs. | 140 lbs. | 170 lbs. |
| 105 lbs. | 125 lbs. | 145 lbs. | 190 lbs. |
| 110 lbs. | 130 lbs. | 155 lbs. | 235 lbs. |
| 115 lbs. | 135 lbs. |          |          |

1. When there are consecutive days of team competition, there shall be a one (1) pound additional allowance granted each day for all wrestlers (up to a maximum of two (2) pounds for any weigh-in). In order to be granted this one (1) pound additional allowance, a minimum of 48 hours advance notice is required for the opponent(s). NOTE: There shall be no consecutive day weight allowance granted for teams/athletes which compete the day before any post-season championship series tournament.
2. The GHSA does not approve any practice that endangers the health and safety of wrestlers. Crash dieting, the use of diuretics and other drugs for rapid weight reduction, the use of a sweat box, any type of vinyl or plastic sweat suit or bag, hot showers, whirlpool, or any other type of artificial heat device for rapid weight reduction is prohibited.
3. Effective for ALL weekday meets and tournaments, all weigh-in procedures of the National Federation (Rule 4-5) will apply.
4. In tournament competitions (regular season dual and invitational, and the State Championship series), wrestlers shall **not** have an option to weigh-out at the conclusion of the first day of competition. All weigh-ins shall take place prior to the start of competition each day.
5. All contestants may engage in legal weight loss activities on site until weigh-ins begin. Once weigh-ins begin, activities that promote weight loss/dehydration or weight gain are prohibited. Contestants shall not leave the designated weigh-in area unless permission is granted by the school administrator or meet director.
6. Only two (2) certified coaches (affiliated with the school of the athlete on the mat) will be allowed at mat side during regular season tournaments and at the Region/Area Tournament, State Tournament and State Finals.

H. Coaching requirements:

1. All coaches are required to complete the GHSA/NFHS Wrestling Rules Clinic which includes the policies and procedures for the "Wrestling Weight Management Program" presented online via the GHSA web site.
2. Failure to abide by the above requirements will result in fines assessed against the school.
3. Prior to all competitions, coaches must present a properly-dated weigh-in roster (created no more than three (3) calendar days prior to the event) to the head official, demonstrating that the Weight Management Program is being followed.

I. All wrestling matches shall be held with officially-dressed wrestling officials who are registered under the GHSA plan for the registration of officials.

1. Before each meet, the referee shall perform skin checks and sign a verification form.
2. The referee shall also check for items outlined as pre-meet duties for officials in the NFHS Wrestling Rules Book.

J. Appropriate health-care professionals shall be available at all wrestling tournaments.

K. Communicable Skin Disorders:

1. The GHSA **strongly recommends** that wrestling mats be left unrolled during the competitive season, and be disinfected a minimum of three (3) times per week with a medically-approved cleansing solution.
2. In the event an athlete develops a skin disorder or skin lesion that is considered contagious, the school must complete and provide the "Physician's Release for Wrestler to Participate" form. No other form of documentation will be accepted at the site of the competition. The release form is to be presented by the coach at the weigh-in or prior to competition. NOTE: The form and information can be found on the GHSA web site ([www.ghsa.net](http://www.ghsa.net)).

- L. When a coach is charged with a flagrant misconduct penalty, that individual must go to a location outside the “sight and sound” of the competitive area, and can have no interactions with wrestlers or any other team personnel (removal from premises).

**WEIGHT MANAGEMENT PROGRAM:**

- A. All GHSA wrestling schools will participate in the mandatory and binding “Weight Management Program.”
- B. Schools must enter weigh-in results in the computerized weight management program (OPC) within 48 hours of each weigh-in or before the next scheduled contest (whichever comes first). An athlete’s weight descent plan ends on the Last Play Date indicated on the Beginning and Ending Dates table at the front of this publication; it is not necessary to enter Region/Area Traditional tournament weights into the OPC.
- C. The “Wrestling Weight Management Coaches Handbook,” which contains details of program guidelines and forms, will be posted on the GHSA web site.
- D. Schools must have **all** scales used for wrestling weigh-ins certified annually by the Georgia Department of Agriculture (Fuels and Measures; 404-656-3605).

**TEAM DUAL WRESTLING****GENERAL INFORMATION**

- A. Team Dual Wrestling will be a state open meet with separate competitions in all seven classifications and Girls. NOTE: The seeding/bracketing committee will seed/bracket teams before the State Dual Championship.
- B. National Federation and GHSA rules governing Traditional wrestling are in effect for Team Dual Wrestling.
- C. GHSA weight certification policies will apply to Team Dual Wrestling.
- D. Athletes may not wrestle at a weight class lower than allowed by the “Weight Loss Plan” of the GHSA Weight Management Program for that date.
- E. All wrestlers must weigh-in at each weigh-in of a multiple-day event, and they must weigh-in at the same weight class each time.
  - 1. A wrestler is only eligible for two weight classes during a multiple-day team advancement tournament.
  - 2. The weight classes for which a wrestler is eligible to compete are determined on the first day’s weigh-in, and cannot change during the remainder of the event.
- F. Teams may weigh-in all eligible and weight class-certified wrestlers.

**REGION/AREA TOURNAMENTS:**

- A. *Each Region/Area may determine its procedure for selecting and ranking its top two (2) teams for the state playoffs by the date indicated in the Beginning and Ending Dates table at the front of this publication.*
- B. Schools which do not qualify for the State Dual Tournament may schedule individual matches and/or tournaments on the dates of the State Duals Championships.

**STATE TOURNAMENTS:**

- A. *Two (2) teams from each Region/Area will advance to the double-elimination Team Dual State Tournament. The Team Dual State Championships for all classes and Girls will be held at a site or sites to be determined on the dates indicated in the Beginning and Ending Dates table at the front of this publication. (See the GHSA web site for final information).*
- B. *The teams advancing to the state tournament must be designated to the GHSA office immediately after the Region/Area has determined the teams, but all must be designated by the date indicated in the Beginning and Ending Dates table at the front of this publication.*
- C. The GHSA will assign and pay all officials for State Championships.

- D. Trophies and medals will be provided by the GHSA and will be presented to the State Champion and the Runner-up in each classification.
- E. Each school participating in the State Dual Championship will be allowed **free admission** for a maximum of 28 wrestlers and team essential personnel. Coaches will be admitted with a GHSA coaching pass.
- F. Admission fees are TBD and will be posted on the GHSA web site.
- G. In the event the State Dual Tournament ends in a tie, the winner shall be determined using the National Federation tie-breaking system published in the Wrestling Rules Book (rule 9-2-2).
- H. All weigh-ins for the State Dual Tournament will be in accordance with the NFHS Rule 4-5. Exact times will be determined by tournament administration.

### TRADITIONAL WRESTLING

#### REGION/AREA TOURNAMENTS:

- A. Region/Area tournaments in classes A through 7A and Girls may be held on the dates indicated in the Beginning and Ending Dates table at the front of this publication. Those hosting Region/Area Tournaments are encouraged to hold a one-day tournament whenever possible. NOTE: Hosts are required to run the tournament through **TrackWrestling**.
- B. Classes A through 3A and Girls will be divided into Areas with consideration to geographic proximity and to the number of schools involved. The top four (4) wrestlers in each weight class from each Region/Area Tournament (classes A through 7A and Girls) will advance to the State Tournament.
- C. A listing of all traditional Region/Area Tournament sites can be found on the GHSA web site.
- D. Officials are to be secured and paid by the Region/Area.
- E. All finances will be handled by the Region/Area, including all expenses, payment of officials and distribution of receipts.
- F. Region ticket prices are set by the Region. Area ticket prices are \$8.00 per day, or a total tournament ticket for two-day events may be sold for \$14.00. The GHSA will receive 5% of the gross gate receipts.
- G. Scoring for wrestlers failing to report, failing skin checks, not weighing in or not making weight will follow NFHS guidelines for forfeitures.
- H. JV Region/Area Tournaments may be held as long as they are completed by the last play date of the season. The JV tournament date(s) will count toward the maximum number of playing dates allowed. JV Region/Area tournaments do not need GHSA sanctioning.

#### STATE TOURNAMENTS:

- A. All State Tournaments will be held on the dates indicated in the Beginning and Ending Dates table at the front of this publication.
- B. Schools in all classifications and Girls will be assigned to State Tournament sites. A listing of all State Tournament sites can be found on the GHSA web site.
- C. The top six (6) wrestlers in each weight class from each State Tournament will advance to the State Championship Finals. In Girls, the top three (3) wrestlers in each weight class from each State Tournament will advance to the State Championship Finals. NOTE: The State Tournaments are qualifying tournaments only, therefore no team scoring will be used. However, penalties which normally result in team point assessments will have the team point(s) deducted at the start of the State Championship Finals.
- D. Officials in all classes and Girls will be assigned and paid by the GHSA.
- E. All replacements for wrestlers who qualified for the Sectional Tournaments and State Tournaments should be reported to the GHSA office by noon on the Wednesday immediately following the Region/Area Tournament and Sectional Tournaments.

- F. Admission fees for State Tournaments will be posted on the GHSA web site.

#### STATE CHAMPIONSHIP FINALS:

- A. The Traditional State Finals will be held at the Macon Centreplex on the dates indicated in the Beginning and Ending Dates table at the front of this publication.
- B. Reports of wrestlers advancing to the State Finals must be transmitted electronically to Track Wrestling no later than 10:00 p.m., on the date the State Tournament is completed. Specific reporting instructions will be forwarded to each State Tournament Director.
- C. All replacements for wrestlers who qualified for the State Finals should be reported to the GHSA office by noon on the Wednesday immediately following the State Tournament. A wrestler who cannot wrestle (for any reason) at the State Tournament may be replaced by an alternate (from the same State Tournament) prior to the Wednesday preceding the State Finals.
- D. Wrestlers must wrestle in the Region/Area and State Tournaments at the weight certified in accordance with all provisions of the GHSA Wrestling Weight Management Program.
1. All weigh-ins for the State Championship Finals will be in accordance with the NFHS Rule 4-5.
  2. Exact weigh-in times will be determined by tournament administration.
- E. Admission price for the State Finals is TBD and will be posted on the GHSA web site.
- F. Each school participating in the State Finals will be allowed **free admission** for all wrestlers who qualify for the tournament and any wrestlers and wrestlerettes who volunteer to work the tables at the State Championships.
- G. Schools having athletes qualified for the State Finals must electronically submit the "Roster of Admissions Form" found on the GHSA MIS website. The deadline to submit this form is noon on the Monday immediately following the State Tournament. Only persons listed on this form will be admitted without charge.
- H. The State Finals will be scored to six (6) places.
- I. Full wrestlebacks (double elimination) will be allowed in all classifications. Cross-bracketing shall be used for wrestlebacks.
- J. Each school will be assessed \$10.00 per participating wrestler to cover the rental and cleaning of the state championship site.

## ESPORTS

#### GENERAL INFORMATION:

- A. Esports is a state championship co-ed event open to all GHSA schools in all classifications.
- B. There will be a fall season and a spring season each year, with specific dates published on the GHSA web site.
- C. Each game's championship will be determined by a single-elimination tournament.
- D. *Each school may have multiple teams, and players may participate in multiple games. Esports Coaches must complete an annual Rules Clinic.*
- E. Eligibility reports are required for all participants.
1. Participants must be academically eligible as specified in by-law 1.50, and cannot be a migrant student as defined in by-law 1.60.
  2. Eligibility reports must be received in the GHSA office at least 20 calendar days prior to the first contest.
- F. All matches and game rules will be overseen and managed by PlayVS. In addition to PlayVS rules, schools must follow GHSA by-laws, which will take precedence over PlayVS procedures. All Esports participants are reminded they must follow GHSA by-law section 1.90 concerning **Amateur Status/Awards**.
- G. PlayVS will specify equipment needed for competition in each game. In general, coaches should have access to the communication platform utilized by PlayVS.



- H. Sportsmanship of coaches and players will be monitored by PlayVS and the GHSA.
- I. Rosters will be managed during registration for the games with PlayVS.
- J. All practices and matches must be conducted in the physical presence of a certified coach. Students may not play GHSA Esports from home.
- K. Forfeitures without timely communication beforehand may be grounds for fines and/or other penalties.
- L. The State Coordinator for Esports is Tanya Anderson ([tanyaanderson@ghsa.net](mailto:tanyaanderson@ghsa.net)).

## LITERARY

### GENERAL INFORMATION:

- A. Literary is a Fine Arts and Academic event that produces State Champions in each classification.
  - 1. The Literary events include the following:
    - (a) Literary Interpretation - Solo Dramatic, Solo Humorous and Duo (dramatic or humorous)
    - (b) Essay - Personal, Argumentative and Literary Analysis
    - (c) Extemporaneous Speaking - Domestic and International
    - (d) Music Events: Boys Solo, Girls Solo, Trio and Quartet
  - 2. Eligibility reports are required for all Literary contestants.
    - (a) Contestants must be academically eligible as specified in By-Law 1.50, and can not be a migrant student as defined in By-Law 1.60.
    - (b) Eligibility reports must be received in the GHSA Office at least twenty (20) calendar days prior to the first contest.
- B. The rules and regulations of the GHSA as developed and enforced by state and region personnel and as published in the GHSA Constitution and By-Laws shall govern the operation of all Literary meets.

NOTE: It is important that all rules be followed precisely in all competitions leading up to the state competition in order to avoid "surprise" disqualifications.
- C. In Literary, a student may represent their school in not more than two (2) individual events and one group event, or two (2) group events and one individual event. A school may have only one entry per contest. NOTE: There may be a conflict in schedule when a student is in two events.
- D. Schools are encouraged to avoid using the same performance selections in consecutive years.
- E. In Literary, audiences will be allowed in the competition room (if space allows) for all events with the exception of Essay and the Extemporaneous Speaking Prep Room.
- F. Photography or video or audio recording will not be allowed at any GHSA Literary event or One Act Play.
- G. *Decisions related to rules' violations can be made only by judges (acceptable criteria are met) or tabulators (timing infractions) in collaboration with the Meet Director.*
- H. *Literary is an inclusive competition. Students with academic accommodations are allowed to compete and receive their accommodations. Appropriate documentation must be provided to GHSA and the Region Coordinator and State Coordinator by the registration deadline.*
  - 1. *Items to be presented to GHSA, the Region Coordinator, and the State Coordinator include the following:*
    - (a) *a copy of the student's official education plan (504 or IEP) - the plan should be used by the student both in the classroom on a daily basis as well as on standardized assessments.*
    - (b) *a written request for the accommodation from the member school's administration*
  - 2. *The following rules will apply for students who receive technology-based accommodations:*
    - (a) *the school must provide a device and a printer.*
    - (b) *the contestant must arrive 30 minutes prior to the beginning of the competition time to ensure that all technology is set up and functioning properly.*
    - (c) *the device cannot be connected to the Internet.*
    - (d) *the word processing program must not have spell check or grammar check capabilities (suggestions: TextEdit on a Mac or Notepad on a PC).*
    - (e) *the device will need a wired connection to a printer.*

(f) *the school must provide the writing device (laptop), printer and ink, all power and connection cables, and paper for the printer.*

- I. Each school wishing to enter Literary must notify the Region Secretary by the deadline date.
  1. The Literary *Roster* must be **electronically** filed at [app.ghsa.net](http://app.ghsa.net) by February 1.
  2. The Region Literary Meets may be held on any date after February 17 provided they are completed by March 9, 2024.
  3. The State Literary Meets will be held on the date indicated in the Beginning and Ending Dates table at the front of this publication. Schedules will be posted on the GHSA web site.

#### REGION INFORMATION:

- A. The first-place winner from every region in each Literary event qualifies for the State Meet.
  1. When the first-place winner in a region cannot compete in the State Meet, the next person or group in the order of finish may replace the original winner.
    - (a) The school whose winner will not compete must notify the Region Secretary so the replacement can be notified.
    - (b) The Region Secretary must notify the GHSA Office about any changes in contestants.
    - (c) **The deadline to make any changes is the Thursday at noon prior to the State Meet**, unless special circumstances exist.
  2. In a Region Meet where there is a tie in any event involving more contestants than the region is entitled to enter in the State Meet, the judges should deliberate and determine a winner. If, because of very unusual circumstances, two students or groups of students are allowed to represent a Region at State Literary for the same position, only one of these can score at the State Meet.
- B. The GHSA Office will furnish each Region Secretary with a copy of score sheets that will be used in region competitions.
  1. The same score sheet used in region competition will be used at the State Meet.
  2. The GHSA score sheet includes:
    - (a) space for the tabulator to note the amount of time allotted for the event and the amount of time used by the contestant.
    - (b) space for the rank of the contestant to be clearly noted
    - (c) a place in which to write the name of the selection(s) performed
    - (d) the number of possible points available
    - (e) space for written comments that reflect why points were deducted from presentations.
  3. Individual copies of the score sheet may be obtained from the GHSA Office or the GHSA web site.
- C. Miscellaneous Regulations:
  1. During competitions, contestants will be identified by order of appearance numbers **ONLY**.
  2. A director/coach is expressly prohibited from conducting during a musical contest at the region and state competitions.
  3. Digitally created music downloaded from the Internet may be used so long as all copyright laws have been met. It is the school's responsibility to make sure all copyright laws have been met. There must be proof provided to the judges at the time of check-in with website documentation in the case of music being downloaded from public domain websites.
  4. Each school having one or more students participating must have a school representative at the Region and State Meets.
  5. Judges will rank the contestants based on the point totals of each contestant.
    - (a) Winners will be chosen by adding up the rankings of each judge.
    - (b) There can be no tied rankings or point totals on any judge's score sheet. NOTE: Judges shall not score a presentation below 70 except in very unusual circumstances.
    - (c) In the event of a tie between contestants when the rankings are tallied, point totals will be used to break the tie.
    - (d) All decisions are final. Mistakes due to mathematical errors or decisions made contrary to GHSA rules that are discovered before or after the decision of the judges shall be corrected.
    - (e) Judges will be seated in different parts of the competition room, and will render their decisions without conferring. NOTE: When necessary, judges may sit together to view a single piece of music, but they may not confer with one another.
  6. The presiding official at each event shall not (by word, gesture, or any other expression) indicate approval or disapproval of the performance of the contestant.

7. For timed events:
  - (a) an **adult timekeeper (may not be a high school student) MUST** be present at all region and state events.
  - (b) the timekeeper shall not be a judge.
  - (c) The **adult timekeeper** *will show time cards upon request*, record times and provide them to the event coordinator or tabulator at the end of the competition.
  
- D. Point totals for determining the Region Champion and State Champion in Literary are as follows:  
 First place - 7 points; second place - 5 points; third place - 3 points; fourth place - 1 point. NOTE: If two contestants finish with equal ranking points and numerical points, each school will receive half the points for the two positions combined.

#### STATE INFORMATION:

- A. The State Literary Coordinator is **Tim Harris** (e-mail: [tim.harris@bufordcityschools.org](mailto:tim.harris@bufordcityschools.org)).
  
- B. The GHSA will provide:
  1. A competent person at each State Literary Meet to discuss the rules with the judges prior to the contest.
  2. Two competent judges to adjudicate each competition.
  3. Written copies of the rules for each competition.
  
- C. Completed score sheets at the State Meet are submitted by the judges to the chairperson of each contest.
  1. The chairperson will place the score sheets in a properly marked envelope, seal it, and turn it in to the GHSA representative.
  2. The envelope will be opened by the GHSA representatives who will tabulate the results and announce the winners.
  3. In the event of error by the judges (i.e., mathematical errors, having tie scores, etc.) the score sheets will be returned to the judges for correction.
  4. Ties in the State Meet shall stand, and the points shall be divided equally among those who are tied.
  5. All judges decisions are final. Protests are not allowed. (Note: Judges do not disqualify. They submit reasons they would disqualify to Region or State Chairpersons to confer, as needed, with a GHSA representative.)
  
- D. Schedules for the State Meet will be posted on the GHSA web site.

#### SECTION L1 LITERARY INTERPRETATION

- A. Separate contests will be held in Solo Dramatic Interpretation, Solo Humorous Interpretation and Duo Interpretation (dramatic or humorous) in all classifications.
  
- B. This is a competition involving the communication of prose, poetry, and/or dramatic literature.
  1. The selection should be of good literary value and taken from a book, play, musical or online written source. Student-written pieces and selections from television or movie scripts, video games or social media platforms are **not** allowed.
  2. The contestants are judged on how well they communicate the author's meaning to the audience.
    - (a) The contestant is expected to give the audience a brief introductory statement about the selection(s), including the author, title and a brief context (This introduction is not required to be presented at the beginning, but can be embedded into the presentation.)
    - (b) The material must be memorized and delivered without the use of a manuscript.
    - (c) No costumes, props, music, or sound effects may be used in the presentation. The area of presentation should be completely vacant.  
 NOTE: Definition of Properties from The Stage and The School, 8th Edition, 1999, page 600: All the stage furnishings, including furniture and those things brought onstage by the actors; also called props.
    - (d) Movement, physical contact and eye contact are allowed.
    - (e) Coaches are encouraged to develop interpretations that are unique and not copied from other sources or online performances.
  3. Contestants participating in solo interpretation (dramatic or humorous) should portray a minimum of two characters in their presentation.
  4. A student may participate in only one individual contest in Literary Interpretation but may also enter in the group event of Duo as per GHSA Rules. (GHSA Literary students may enter two (2) individual events and one (1) group event, or one (1) individual event and two (2) group events. The two (2) individual events cannot be in the same discipline.)

5. Roles/characters in Duo Interpretation must be balanced. In other words, one performer should not speak the majority of the time.
- C. Each contestant's interpretation must be a minimum of five (5) minutes and no more than ten (10) minutes in length.
1. The time allotment includes the introduction to the interpretation.
  2. *The **adult timekeeper** will show time cards upon request, record times and provide them to the event coordinator or tabulator at the end of the competition.*
  3. Any performance that does not meet the minimum length (5 minutes) or exceeds the maximum length (10 minutes) will be scored but cannot be ranked First.
- D. If the order of performance is not assigned by the GHSA, contestants shall draw for order of presentation upon reporting to the site of the competition.
1. Contestants who are not present at the time of the drawing, will have their position drawn for them.
  2. Contestants who have conflicts with other Literary events should consult with the GHSA prior to the contest, and may have early or late presentation positions designated for them.
  3. The first place winner in each Region competition shall advance to the State competition.
  4. Judges shall follow scoring directions provided by the GHSA office.
- E. There shall be two (2) judges assigned to this competition at the Region and State levels.
1. The following criteria will be considered in the judging:
    - (a) selection of material
    - (b) communication skills
    - (c) vocal technique
    - (d) physical technique
  2. The judges shall use GHSA scoring sheets and shall follow scoring directions given to them by the GHSA Office.

## SECTION L2 ESSAY

- A. Separate contests will be held in Argumentative Essay, Personal Essay and Literary Analysis in all classifications. A student may compete in only one (1) of the essay categories.
- B. This is an on-the-spot writing contest in which contestants are provided with topics on which to write.
1. The GHSA Office shall select at least three (3) topics for the contests in Argumentative Essay and Personal Essay, and two (2) topics in the Literary Analysis contest.
    - (a) Argumentative Essay topics will be selected from current events discussed in the media through the end of January prior to the competition.
    - (b) Personal Essay topics will be short prompts designed to elicit creative and descriptive narrative responses.
    - (c) Literary Analysis topics will be excerpts from prose or poetry along with a prompt that directs students to use evidence, support and commentary to develop a defensible interpretation of the excerpt.
  2. For the Region competition, the GHSA Office will send the topics to the Region Secretary (or their designee) in sealed envelopes, and the seal will be broken for the first time in the presence of the contestants at the competition site.
  3. For the State competition, the GHSA Office will send topics to the State Literary hosts in sealed envelopes, and the seal will be broken for the first time in the presence of the contestants at the competition.
  4. Topics used at State Literary will be different from those used at Region Literary.
- C. Contest Rules:
1. Contestants will compete at the same time in a group setting.
  2. Contestants will have one (1) hour to write their essay. Contestants must stop writing when time is called.
  3. Contestants may NOT use a dictionary or other reference materials during the competition.
  4. Essays shall be written on lined paper in blue or black ink.
  5. Contestants must provide their own paper and pens.
  6. This is an on-the-spot writing contest. Any evidence of pre-written, memorized or plagiarized compositions will result in disqualification.
  7. The first place winner in each Region competition shall advance to the State competition.
- D. Judging Criteria:
1. The essays shall be judged on the following:
    - (a) Thesis & Line of Reasoning (20%)
    - (b) Content & Development (20%)

- (c) Analysis & Support (20%)
- (d) Organization & Structure (20%)
- (e) Style & Sophistication (20%)

### SECTION L3 EXTEMPORANEOUS SPEAKING

- A. Separate contests will be held in Domestic and International Extemporaneous Speaking in all classifications.
- B. This is a speaking contest in which contestants are provided with a selection of topics dealing with current national and international issues that have been discussed in periodicals since September 1, of the current year that have been compiled by the GHSA Office. In late January, the GHSA will distribute three (3) general areas that topics will be chosen from in both Domestic and International Extemporaneous.
  - 1. Contestants will be allowed to use one note card (either 3x5 or 4x6) during the speech. **NOTE:** Contestants who use more than one notecard or something other than a notecard of the specified size will be scored, but cannot place in the Top 4.
  - 2. Thirty (30) minutes before the contest is scheduled to begin, the student who is to speak first shall draw three (3) topics and select one (1) on which to speak. The remaining two topics are returned.
  - 3. Contestants will draw for topics at seven (7) minute intervals in the order of presentation.
  - 4. The presiding official of the contest shall record the contestant's name, contestant's school, position for presentation, and topic drawn.
  - 5. A student may compete in only one of the two Extemporaneous Speaking disciplines.
- C. The procedure for the contest shall be as follows:
  - 1. After each student has drawn a topic, that student will be escorted to a room where he/she will have 30 minutes to prepare a speech in brief, outline form.
    - (a) Students should not compose and read an entire speech from their notecard.
    - (b) Students cannot leave the prep room during their 30-minute prep time.
  - 2. Contestants may not receive assistance from another person, but may use any paper copy materials that have been brought to the site as well as self-contained computers or laptops. (Cell phone and/or smart phone use and Internet access IS NOT allowed and will result in disqualification. Cell phones must be left outside the prep room or with the monitor). Contestants may make use of a computer or laptop to store and to retrieve subject matter only. NOTE: If the Internet is needed to retrieve stored material, this retrieval will **not** be allowed.
  - 3. At the end of the preparation time, the contestant will be escorted to the presentation area and the contestant shall give a copy of the selected topic to a judge.
  - 4. Each contestant shall be allotted seven (7) minutes in which to deliver the speech. *The **adult timekeeper** will show time cards upon request, record times and provide them to the event coordinator or tabulator at the end of the competition.* Contestants that exceed the time limit (7 minutes) will be scored, but cannot be ranked First.
  - 5. The first place winner from each Region competition shall advance to the State competition.
- D. There shall be two (2) judges for Extemporaneous Speaking at the Region and State competitions.
  - 1. The judges shall take into consideration the following components:
    - (a) Thesis & Content (20%)
    - (b) Development & Support (20%)
    - (c) Organization & Structure (20%)
    - (d) Language & Delivery (40%)
  - 2. The judges shall use GHSA score sheets and shall follow scoring directions given to them by the GHSA Office.
- E. If the order of performance is not assigned by the GHSA, contestants shall draw for order of presentation upon reporting to the site of the competition.
  - 1. Contestants shall report to the drawing area at the designated time set for the contest.
  - 2. Contestants who are not present at the time of the drawing, will have their position drawn for them.
  - 3. Contestants who have conflicts with other Literary events should consult with the GHSA prior to the contest, and may have early or late presentation positions designated for them.

### SECTION L4 TRIO & QUARTET

- A. Trio and Quartet are singing competitions held in all classifications.
  - 1. The singing parts for these events are as follows:

- (a) Trio - Soprano 1, Soprano 2, Alto
  - (b) Quartet - Tenor 1, Tenor 2, Bass 1, Bass 2
  2. Two selections shall be sung from memory.
    - (a) Both selections shall be appropriate for a small group of singers.
      - (1) For Trio, both selections should be specifically arranged for SSA and should conform to copyright law.
      - (2) For Quartet, both selections should be specifically arranged for TTBB and should conform to copyright law. *Barbershop arrangements are allowed.*
    - (b) Both selections must be copyrighted, published pieces, and not arrangements of instructional or choral pieces. Please limit divisi (i.e., limit to cadences, isolated measure, etc.).
    - (c) One selection must be one of the following:
      - (1) chorale
      - (2) madrigal
      - (3) art song
      - (4) folk song
      - (5) spiritual song
    - (d) One selection must be a cappella.
    - (e) Any group that does not perform selections that meet the above stated criteria will be scored, but cannot place in the Top 4.
  3. A legal copy of the music to be performed must be presented to the judges. The performance should match the instrumentation of the arrangement of the music presented to the judges. (For example, a cappella arrangements should be performed a cappella. Accompanied arrangements should be performed with appropriate accompaniment - points may be deducted for failure to comply.)
    - (a) Live piano accompaniment is the only form allowed (no recordings allowed).
    - (b) Contestants must bring their own accompanist if one is to be used.
    - (c) Any group that does not present music to the judges will be scored, but cannot place in the Top 4.
  4. Each group shall be allotted eight (8) minutes to perform their selections. Any group that exceeds the time limit (8 minutes) will be scored, but cannot be ranked First.
  5. An adult is expressly prohibited from conducting during any musical contest at the Region or State levels.
  6. One (1) substitution will be allowed advancing to the State Meet after Region competition.
- B. If the order of performance is not assigned by the GHSA, contestants shall draw for order of performance upon reporting to the site of the competition at the scheduled time.
1. Contestants who are not present at the time of the drawing, will have their position drawn for them.
  2. Contestants who have conflicts with other Literary events should consult with the GHSA prior to the contest, and may have early or late presentation positions designated for them.
  3. At the time of check-in at the competition site, an original copy of the music (may be computer generated) will be presented for viewing by the judges. Each school is responsible for meeting copyright laws. There must be proof provided with website documentation in the case of music being downloaded from public domain websites.
- C. Judging Procedures:
1. Two judges will be used for the Trio and Quartet competitions.
    - (a) Judges shall not confer with one another during the competition, but they may sit near one another to view the copy of the music.
    - (b) Tabulation of score sheets shall be handled independently.
  2. Judges shall follow scoring directions provided by the GHSA Office.
  3. Judging criteria are as follows:
    - (a) Musical Knowledge: Pitch Accuracy, Rhythm Accuracy (20%)
    - (b) Vocal Technique: Tone, Diction (20%)
    - (c) Musicianship: Tempo/Style, Phrasing, Dynamics (30%)
    - (d) Other Observations: Ensemble, Stage Presence, Choice of Music (30%)

## SECTION L5 SOLO

- A. Separate contests will be held for boys and girls in vocal Solo.
- B. Two selections shall be sung from memory:
  1. One selection must be from the standard repertory of the art song, oratorio aria, or operatic aria, folk or spiritual. Any contestant that does not perform selections that meet this stated criteria will be scored, but cannot place in the Top 4.

2. Both selections should be from appropriate solo literature and not arrangements of instructional or choral pieces. All music selected should conform to copyright law.
  3. A legal copy of the music to be performed must be presented to the judges. The selections may be sung with or without accompaniment. The performance should match the instrumentation of the arrangement of the music presented to the judges. (For example, a cappella arrangements should be performed a cappella. Accompanied arrangements should be performed with appropriate accompaniment - points may be deducted for failure to comply.)
    - (a) Live piano accompaniment is the only form allowed (no recordings allowed).
    - (b) Soloists must bring their own accompanist if one is to be used.
    - (c) Any contestant that does not present music to the judges will be scored, but cannot place in the Top 4.
  4. Each Soloist shall be allotted eight (8) minutes to perform their selections. Any contestant that exceeds the time limit (8 minutes) will be scored, but cannot be ranked First..
  5. An adult is expressly prohibited from conducting during any musical contest at the Region or State levels.
  6. Soloists are not allowed to use any type of instrument or prop.
- C. If the order of performance is not assigned by the GHSA, contestants shall draw for order of performance upon reporting to the site of the competition at the scheduled time.
1. Contestants who are not present at the time of the drawing, will have their position drawn for them.
  2. Contestants who have conflicts with other Literary events should consult with the GHSA prior to the contest, and may have early or late presentation positions designated for them.
  3. At the time of check-in at the competition site, an original copy of the music (may be computer generated) will be presented for viewing by the judges. Each school is responsible for meeting copyright laws. There must be proof provided with website documentation in the case of music being downloaded from public domain websites.
- D. Judging Procedures:
1. Two judges will be used for the Solo competition.
    - (a) Judges shall not confer with one another during the competition, but they may sit near one another to view the copy of the music.
    - (b) Tabulation of score sheets shall be handled independently.
  2. Judges shall follow scoring directions provided by the GHSA Office.
  3. Judging criteria are as follows:
    - (a) Musical Knowledge: Pitch Accuracy, Rhythm Accuracy (20%)
    - (b) Vocal Technique: Tone, Diction (20%)
    - (c) Musicianship: Tempo/Style, Phrasing, Dynamics (30%)
    - (d) Other Observations: Artistry, Stage Presence, Choice of Music (30%)

## ONE ACT PLAY

### GENERAL INFORMATION:

- A. One Act Play is a Region event in all classifications.
1. Each school wishing to enter One Act Play must electronically submit notification of entry at GHSA MIS no later than October 1.
  2. Principals must review the school's play and approve the notification of entry stating that the presentation is acceptable and approved to represent the school in the competition.
  3. Region winners must be determined by the date indicated in the Beginning and Ending Dates table at the front of this publication, and the Region Secretary must file the winner of the Region competition electronically at GHSA MIS immediately following the Region competition.
  4. GHSA One Act Play is an acting competition. Emphasis should be on acting, not on technical elements.
  5. One Act Play Directors designated by each GHSA school MUST complete an annual online One Act Play Coaches Clinic or the school will be fined. Supporting coaches are encouraged to complete the clinic.
  6. Admission may not be charged for One Act Play competitions.
  7. No photography or video or audio recording is allowed of any One Act Play performance.
- B. The GHSA State One Act Play Coordinator and Director of Adjudicator Training is **Dean Slusser**.
- C. The Region Secretary, or a designated Region One Act Play Coordinator, shall make arrangements for the Region One Act Competition.
1. Three GHSA certified judges are required for each Region One Act Competition.
    - a. Region judges shall be recruited by the Region Secretary, Region One Act Play Coordinator, or by such means as determined by the Region.

- b. Questions about certification, assistance in the recruitment of Region judges, and/or information about opportunities for one act play adjudicator training may be directed to GHSA Adjudicator Training Coordinator, Dean Slusser.
  - c. The Region Secretary or other individual tasked with recruiting judges shall designate a Lead Judge at the Region event. The event coordinator will bring any questions about rule interpretation, possible violations, or other concerns to the attention of the Lead Judge for consultation and to determine how to proceed.
  - d. Judges shall not discuss their scores or rankings with one another, or otherwise discuss the plays in the competition, until after all judges have submitted their completed scoresheets to the tabulator or event coordinator.
  - e. On the day of the contest, judges shall avoid contact with directors or cast members until after the winners are announced.
2. Plays are to be announced by the order of appearance number and the title of the play. School names shall not be announced.
  3. Only eligible students are allowed on stage during play performance.
    - a. Piano placement must be outside the performance area if an adult is playing.
    - b. Adults and migrant students may assist in loading and unloading of sets only prior to starting time and once time has stopped. This policy includes the placement of speakers and monitors from the front of the stage onto the apron.
    - c. Adults and migrant students may assist with pre-show load in and post-show strike, but may not appear in the performance area, seen or unseen, while time is running.
  4. Score sheets can be found on the GHSA web site ([www.ghsa.net](http://www.ghsa.net)) - Sports & Activities tab - One Act Play - Scoring Forms.
  5. Each Region will announce the following awards as appropriate:
    - a. Region Champion
    - b. Runner-up
    - c. 3rd Place
    - d. 4th Place
    - e. Best Actress
    - f. Best Actor
    - g. Up to two All-Star Cast awards may be presented to each production, but required recognition for every production shall be at the discretion of the Region.
    - h. Other recognition as determined by the Region.

#### **SPECIFIC CONTEST RULES:**

- A. Schools may choose to enter a one act play or musical, or an excerpt or abridgement of a longer play or musical as their One Act Play selection.
  1. Each school assumes full responsibility for royalties and other limitations on the selected play.
  2. Schools choosing to enter musical productions shall not use a reproduction of the original soundtrack as part of the presentation.
  3. Musical accompaniment tracks must be licensed recordings without vocals. Professional vocals on accompaniment tracks are prohibited.
  4. A school may not compete with a play or musical that was produced or work-shopped in the previous school year or previous two summers. Schools found in violation of this rule will be disqualified from competition.
- B. Each school is given 55 minutes to set-up, perform, and take down its presentation.
  1. The official time will be kept by an assigned adult timekeeper.
  2. The adult timekeeper will record times and provide them to the tabulator at the end of the competition, after all the judges have completed scoring the plays.
  3. Any school that exceeds its time allotment will be penalized two (2) points for each 15-second period or portion thereof per judge.
  4. The tabulator, not the judges, will deduct points for overtime.
- C. The site host shall establish and tape "go lines" to separate the playing area from the backstage area.
  1. These lines shall be placed: at the wing line on stage right; at the wing line on stage left; at the mid-stage traveler line (or at mid-stage if there is no traveler); and at the upstage traveler line (or upstage, allowing for a backstage pathway, if there is no upstage traveler).
  2. All set pieces must be placed behind these "go lines" at the end of the 15-minute walk-through prior to time starting for the competition performance, and moved in FRONT of the lines in order to be considered on stage and used in the performance.



3. Each director shall choose whether to use the mid-stage or upstage line to designate "off stage" for his/her school's production. The line selected to begin the performance shall be used to end the performance.
- D. Each school is responsible for its own sets.
1. Each school will be allotted a 15-minute walk-through immediately prior to its competition performance. Schools may use this time for any show prep activities they choose, including, but not limited to: walking the stage; setting sound levels; running light checks or cues; practicing set-up and strike.
  2. All production-related materials must be back in their pre-show positions behind the "go lines" by the end of 15 minutes. If they are not set up at the end of that 15-minute interval, timing of their play begins and counts towards their 55-minute limit. **TIME WILL NOT BE STOPPED TO ALLOW FOR COMPLETION OF THE SHIFT.**
  3. Spike tape may be placed during the 15-minute walk-through, and may remain through the end of the performance, but must be removed before timing will be stopped.
  4. Schools are timed "bare-stage to bare-stage." Time will not stop until all set pieces, confetti, or other debris has been removed from the defined playing area.
  5. Keep sets simple. Sets are not to be excessively large or so complicated as to delay the flow of the competition.
  6. Only free-standing set pieces may be used. No part of any setting may be attached to any part of the stage, curtains, draperies, or other existing equipment of the host school.
- E. Each school is responsible for its own props, costumes, make-up and special effects.
1. No flame of any type can be used, including candles.
  2. Real weapons of any kind, such as a sword or knife, etc., cannot be used.
  3. Schools using simulated weapons must carry with them a letter from the school principal authorizing their use, and must confirm permission with the site host that the use of simulated weapons is allowed by the host school and/or system.
  4. Use of simulated weapons cannot be in violation of any local board of education policy of the participating school or the host site. Violation of this rule will result in disqualification (zero tolerance rule). Contact the host school for any clarification of its rules.
  5. The use of microphones is allowed.

**ADDITIONAL GUIDELINES FOR REGION/AREA AND STATE COMPETITION:**

- A. The facilities that will be used for One-Act Play competitions will not be available for practice or walk-through by any school in the State competition.
- B. Schools will be responsible for making their own arrangements for housing and meals.
- C. Trophies and individual medals will be awarded to the State Champion and Runner-up schools, and medals will be awarded to the Outstanding Actor and Outstanding Actress in the competition. Up to two All Star Cast Certificates may be presented to each production, but there is no requirement that every show receives recognition.
- D. Scoring procedures for both Region and State contests shall be as follows:
  1. No judge shall assign a numerical score lower than 70.
  2. Each judge shall submit completed, signed score sheets to the event tabulator, after which the judges may engage in discussion concerning awards for Best Actor, Best Actress and All-Star Cast.
  3. At each Region and State competition, final tabulations should be conducted by a designated tabulator or by the event coordinator. Judges should not tabulate scores. Judges should have no knowledge of the length of performances. The timekeeper shall report times of performances to the event coordinator or tabulator only. The time for each performance should be recorded on the tabulation form.
  4. In order to determine the final results for Region and State competitions, the lowest rank will be dropped by the tabulator for each performance. The two remaining ranks added together will determine placement. In the event of a tie in ranks, points shall first be totaled from the two judges for each play who gave the highest score. Only in the event that the tie remains unbroken shall the points for all three judges be totaled to break the tie.
  5. A copy of the tabulation sheet shall be provided to each director in the competition.

**ADDITIONAL GUIDELINES SPECIFIC TO STATE COMPETITION:**

- A. Three GHSA certified judges are required for each State One Act Competition.
  1. Prior to the first contest of the season, a pool of State judges shall be recruited by State One Act Coordinator, Dean Slusser.
  2. State judges must meet requirements for state one act judges as approved by the GHSA.

3. The State One Act Coordinator shall designate a Lead Judge for each of the Host sites. The site coordinator will bring any questions about rule interpretation, possible violations, or other concerns to the attention of the Lead Judge for consultation and to determine how to proceed.
4. Judges shall not discuss their scores or rankings with one another, or otherwise discuss the plays in the competition, until after all judges have submitted their completed scoresheets to the tabulator or event coordinator.
5. On the day of the contest, judges shall avoid contact with directors or cast members until after the winners are announced.

B. The schedule for **All Classes** shall be:

9:00 - 10:15 am - Region 4  
10:15 - 11:30 am - Region 5  
11:30 - 12:45 pm - Region 6  
12:45 - 2:00 pm - Region 7  
2:00 - 3:00 pm - RECESS  
3:00 - 4:15 pm - Region 8  
4:15 - 5:30 pm - Region 1  
5:30 - 6:45 pm - Region 2  
6:45 - 8:00 pm - Region 3  
8:00 - Judges' Deliberation  
Awards Presentation to follow

# APPENDIX 'A'

## ALLIANCE OF GEORGIA HIGH SCHOOL ASSOCIATION AND AMERICAN ASSOCIATION OF ADAPTED SPORTS PROGRAMS

Since 2001, the GHSA has been involved in an alliance with the American Association of Adapted Sports Programs. This is a growing relationship in which both organizations are working together for the benefit of physically disabled and visually impaired students.

The Georgia High School Association and the National Federation of State High School Associations have long held the philosophy that participation in competitive activities is an integral part of the educational experiences of high school students.

While the GHSA has accommodated participation of disabled students in several sports and activities, we have not ventured into the area of facilitating participation of physically disabled students in adapted sports.

The GHSA recognizes that AAASP is the premier organization administering adapted sports, and the GHSA wishes to partner with AAASP by providing competitive activities for our physically disabled students in addition to lending our resources to their endeavors. Under the leadership of Tommie Storms and Robyn Hootselle, this organization provides tremendous opportunities in the area of adapted sports.

AAASP oversees competitions in wheelchair basketball, wheelchair track, wheelchair handball, power hockey, wheelchair football and beep baseball throughout the state of Georgia. Additionally, AAASP personnel travel throughout the United States helping schools establish and maintain athletic programs for physically disabled students.

**It is important for school personnel to understand the opportunities available for disabled athletes**, and to share that understanding with students in their schools. It is also important that coaches appreciate the value of athletics in the lives of disabled students, and the particular techniques involved in coaching disabled athletes.

AAASP stands ready to assist school personnel in their endeavors. For more information, please use the following contacts:

AAASP  
P.O. Box 451047  
Atlanta, GA 31145  
Phone (404) 294-0070  
Website [www.adaptedsports.org](http://www.adaptedsports.org)

Information about all Adapted Sports programs may be found on the ghsa.net web site by going to the following link: [ghsa.net/adapted-team-sports-information](http://ghsa.net/adapted-team-sports-information)

**APPENDIX 'B'**

**2023-24  
State Playoff Brackets  
For All Sports**

**STATE BASEBALL PLAYOFFS  
2024  
All Classes**

|                        |                       |                          |                         |                     |                         |                          |                       |                        |
|------------------------|-----------------------|--------------------------|-------------------------|---------------------|-------------------------|--------------------------|-----------------------|------------------------|
| 1st Rd.<br>April 23-25 | 2nd Rd.<br>A. 29-M. 1 | Quarterfinals<br>May 4-7 | Semifinals<br>May 10-13 | FINALS<br>May 17-20 | Semifinals<br>May 10-13 | Quarterfinals<br>May 4-7 | 2nd Rd.<br>A. 29-M. 1 | 1st Rd.<br>April 23-25 |
|------------------------|-----------------------|--------------------------|-------------------------|---------------------|-------------------------|--------------------------|-----------------------|------------------------|



**In the first four rounds, the higher-seeded team will host. In any round where both teams are the same seed, a “universal” GHSA coin flip will determine the host school (or the designated home team for Game One in a neutral-site final). Exceptions to the scheduled dates may be made with the approval of the Executive Director.**

**STATE BASKETBALL PLAYOFFS  
2024  
Boys and Girls: All Classes**



**In the first three rounds, the higher-seeded team will host. In the Quarterfinals, if both teams are the same seed, a “universal” GHSA coin flip will determine the host school. In the Semifinal and Final rounds, when playing at a neutral site, the team on the TOP of the bracket will be designated as the home team and will wear white jerseys.**

**STATE FOOTBALL PLAYOFFS  
2023  
All Classes**



In the first four rounds, the higher seeded team will host. If schools are the same seed, see GHSA Constitution, Football Section, for procedure. Note: The GHSA's "universal" coin flip will determine the designated home team when playing at a neutral site if both teams are the same seed.

**STATE FLAG FOOTBALL PLAYOFFS  
2023  
All Classes**

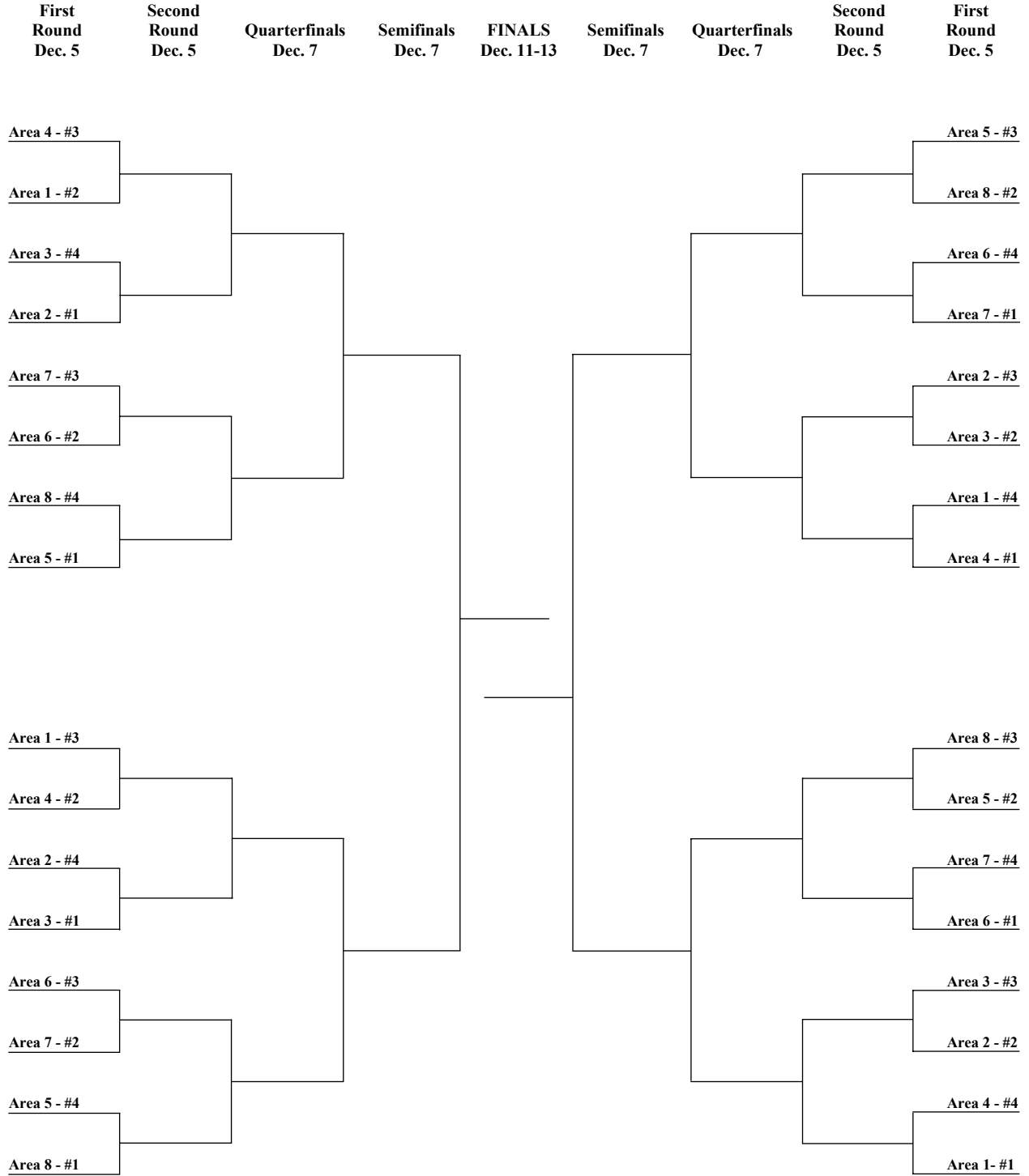

**In the first four (4) rounds, the higher seed in each of the four-team quadrants will host two games to be played on the same date. A universal coin toss will determine the host schools for the second or quarterfinal rounds when teams of equal seeds are left in the same quadrant.**



**STATE LACROSSE PLAYOFFS  
2024  
Boys and Girls: Class 7A**

|                    |                     |                      |                   |               |                   |                      |                     |                    |
|--------------------|---------------------|----------------------|-------------------|---------------|-------------------|----------------------|---------------------|--------------------|
| <b>First Round</b> | <b>Second Round</b> | <b>Quarterfinals</b> | <b>Semifinals</b> | <b>FINALS</b> | <b>Semifinals</b> | <b>Quarterfinals</b> | <b>Second Round</b> | <b>First Round</b> |
| April 23-24        | April 26-27         | April 30-May 1       | May 3-4           | May 9-11      | May 3-4           | April 30-May 1       | April 26-27         | April 23-24        |

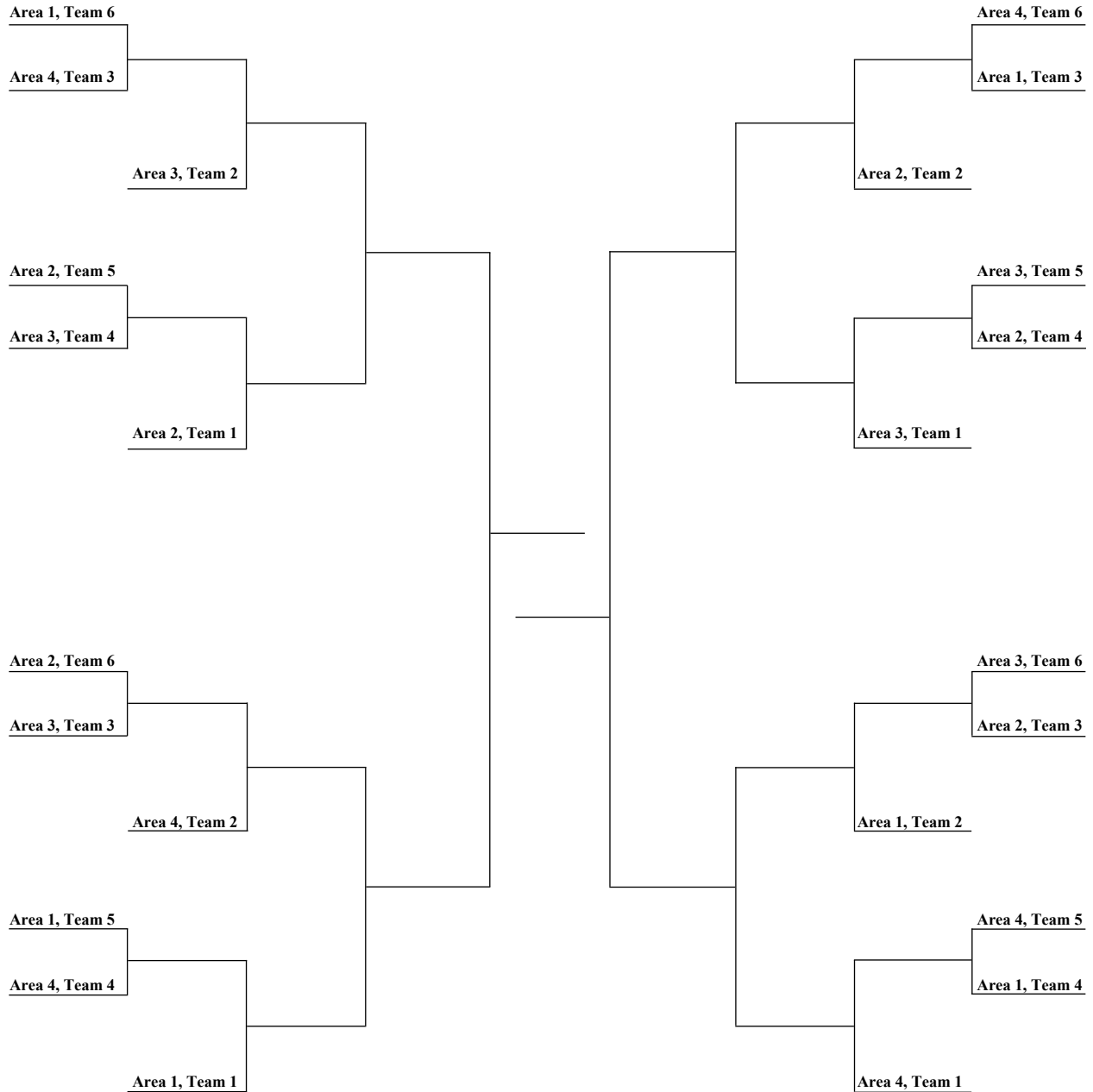

**In ALL Rounds (except neutral-site Finals), the higher-seeded team will host. If both teams are the same seed, a “universal” GHSA coin flip will determine the host school (or the designated home team in a neutral-site Final).**

**STATE LACROSSE PLAYOFFS  
2024  
Boys and Girls: Class 5A-6A**

| First Round<br>April 23-24 | Second Round<br>April 26-27 | Quarterfinals<br>April 30-May 1 | Semifinals<br>May 3-4 | FINALS<br>May 9-11 | Semifinals<br>May 3-4 | Quarterfinals<br>April 30-May 1 | Second Round<br>April 26-27 | First Round<br>April 23-24 |
|----------------------------|-----------------------------|---------------------------------|-----------------------|--------------------|-----------------------|---------------------------------|-----------------------------|----------------------------|
|----------------------------|-----------------------------|---------------------------------|-----------------------|--------------------|-----------------------|---------------------------------|-----------------------------|----------------------------|



**In ALL Rounds (except neutral-site Finals), the higher-seeded team will host. If both teams are the same seed, a “universal” GHSA coin flip will determine the host school (or the designated home team in a neutral-site Final).**

**STATE LACROSSE PLAYOFFS  
2024  
Girls: Class A-4A**

|             |              |                |            |          |            |                |              |             |
|-------------|--------------|----------------|------------|----------|------------|----------------|--------------|-------------|
| First Round | Second Round | Quarterfinals  | Semifinals | FINALS   | Semifinals | Quarterfinals  | Second Round | First Round |
| April 23-24 | April 26-27  | April 30-May 1 | May 3-4    | May 9-11 | May 3-4    | April 30-May 1 | April 26-27  | April 23-24 |



**In ALL Rounds (except neutral-site Finals), the higher-seeded team will host. If both teams are the same seed, a “universal” GHSA coin flip will determine the host school (or the designated home team in a neutral-site Final).**

**STATE LACROSSE PLAYOFFS  
2024  
Boys: Class A-4A**

|                    |                     |                      |                   |               |                   |                      |                     |                    |
|--------------------|---------------------|----------------------|-------------------|---------------|-------------------|----------------------|---------------------|--------------------|
| <b>First Round</b> | <b>Second Round</b> | <b>Quarterfinals</b> | <b>Semifinals</b> | <b>FINALS</b> | <b>Semifinals</b> | <b>Quarterfinals</b> | <b>Second Round</b> | <b>First Round</b> |
| April 23-24        | April 26-27         | April 30-May 1       | May 3-4           | May 9-11      | May 3-4           | April 30-May 1       | April 26-27         | April 23-24        |



**In ALL Rounds (except neutral-site Finals), the higher-seeded team will host. If both teams are the same seed, a “universal” GHSA coin flip will determine the host school (or the designated home team in a neutral-site Final).**

## STATE RIFLERY PLAYOFFS - 2024

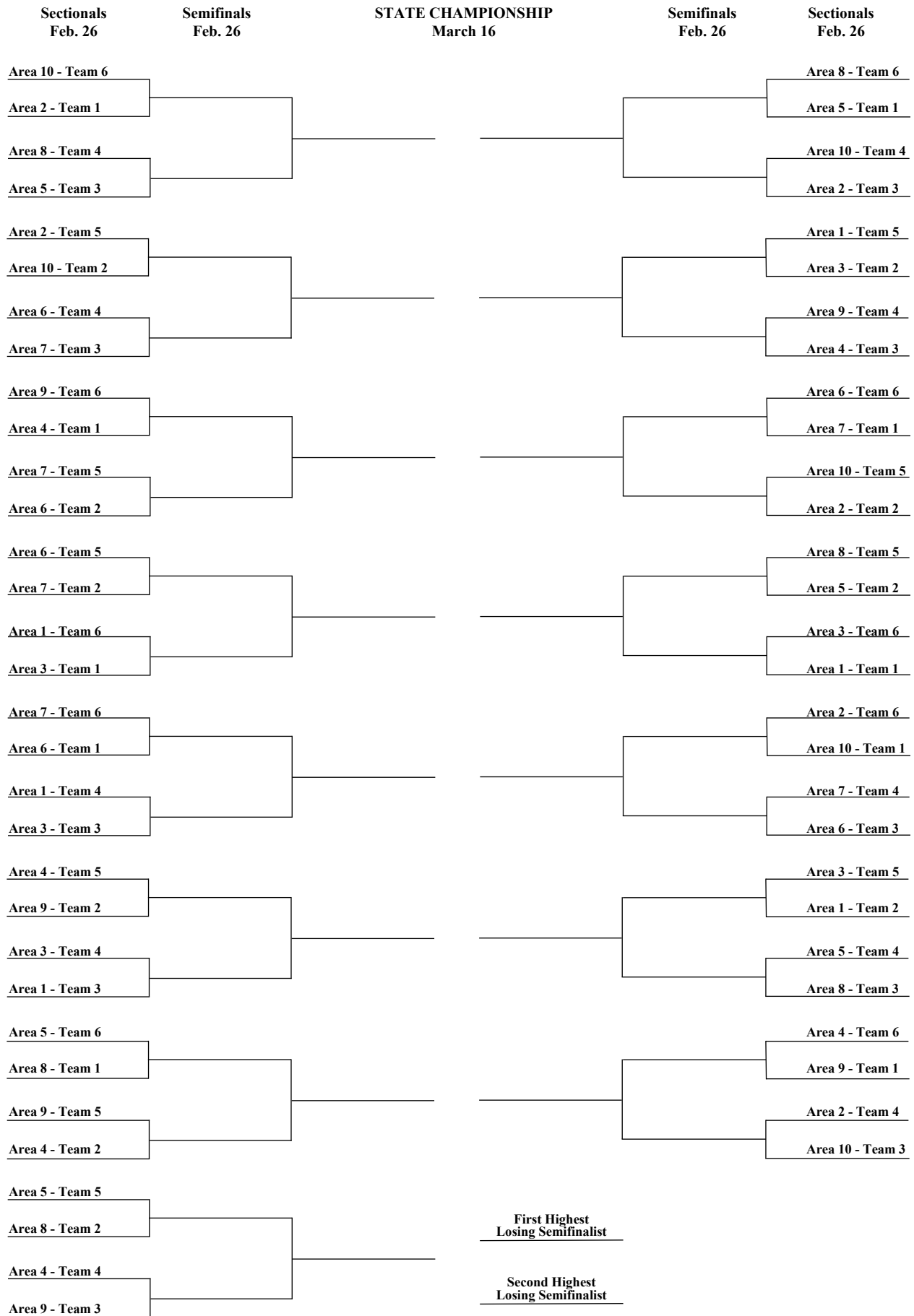

The higher seeded team will host. If teams in the Semifinals are equal seeds, the highest Sectional score will host.

**STATE SOCCER TOURNAMENT  
2024  
Boys and Girls: All Classes**

**A, 3A, 5A and 7A Dates:**

| 1st Rd. | 2nd Rd. | Quarters | Semifinals | FINALS   | Semifinals | Quarters | 2nd Rd. | 1st Rd. |
|---------|---------|----------|------------|----------|------------|----------|---------|---------|
| G: 4/16 | G: 4/23 | G: 4/29  | G: 5/2     | May 7-10 | G: 5/2     | G: 4/29  | G: 4/23 | G: 4/16 |
| B: 4/17 | B: 4/24 | B: 4/30  | B: 5/3     | May 7-10 | B: 5/3     | B: 4/30  | B: 4/24 | B: 4/17 |

**2A, 4A and 6A Dates:**

| 1st Rd. | 2nd Rd. | Quarters | Semifinals | FINALS   | Semifinals | Quarters | 2nd Rd. | 1st Rd. |
|---------|---------|----------|------------|----------|------------|----------|---------|---------|
| G: 4/18 | G: 4/25 | G: 4/29  | G: 5/2     | May 7-10 | G: 5/2     | G: 4/29  | G: 4/25 | G: 4/18 |
| B: 4/19 | B: 4/26 | B: 4/30  | B: 5/3     | May 7-10 | B: 5/3     | B: 4/30  | B: 4/26 | B: 4/19 |



**In ALL Rounds (except neutral-site Finals), the higher-seeded team will host. If both teams are the same seed, a “universal” GHSA coin flip will determine the host school (or the designated home team in a neutral-site Final).**

**STATE SOCCER TOURNAMENT  
2024  
Boys and Girls: Class A, Division 2**

**Dates:**

| 1st Rd. | 2nd Rd. | Quarters | Semifinals | FINALS   | Semifinals | Quarters | 2nd Rd. | 1st Rd. |
|---------|---------|----------|------------|----------|------------|----------|---------|---------|
| G: 4/16 | G: 4/23 | G: 4/29  | G: 5/2     | May 7-10 | G: 5/2     | G: 4/29  | G: 4/23 | G: 4/16 |
| B: 4/17 | B: 4/24 | B: 4/30  | B: 5/3     | May 7-10 | B: 5/3     | B: 4/30  | B: 4/24 | B: 4/17 |



**STATE FAST PITCH SOFTBALL PLAYOFFS  
2023  
ALL CLASSES**

**Super Regional Bracket  
Oct. 16-19**

**STATE TOURNAMENT  
October 25-28  
Columbus - All Classes**

**Super Regional Bracket  
Oct. 16-19**

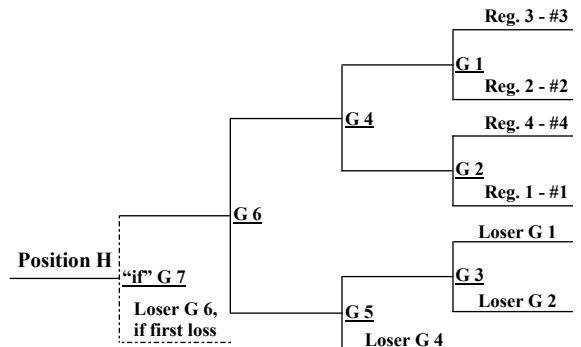
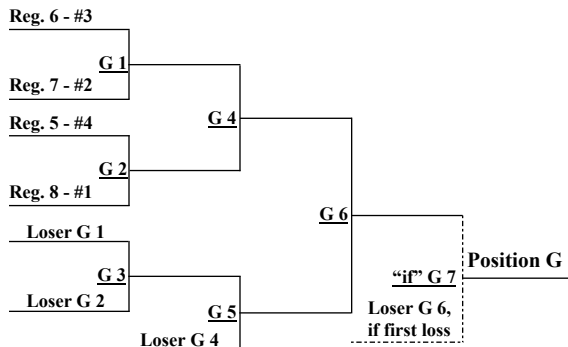
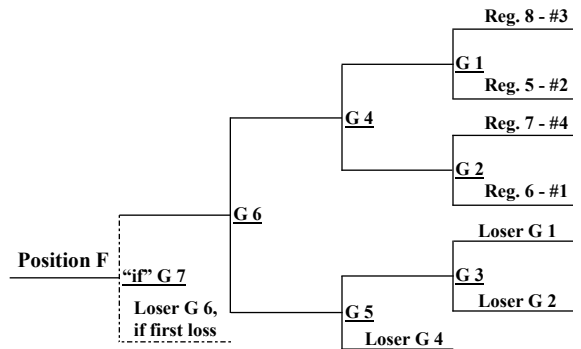
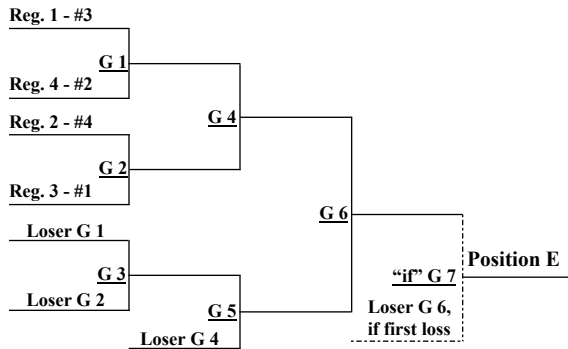
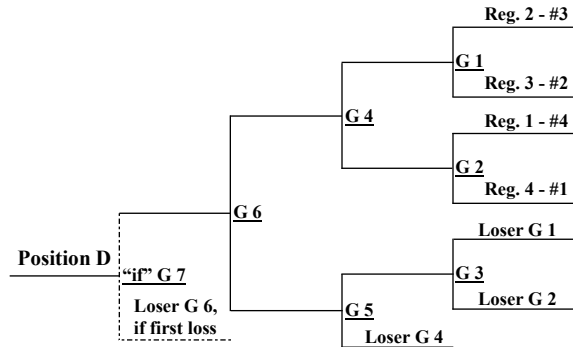
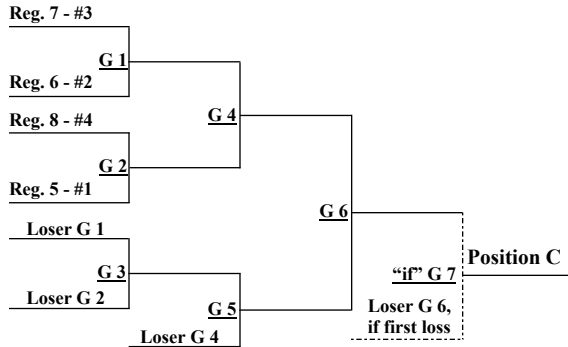
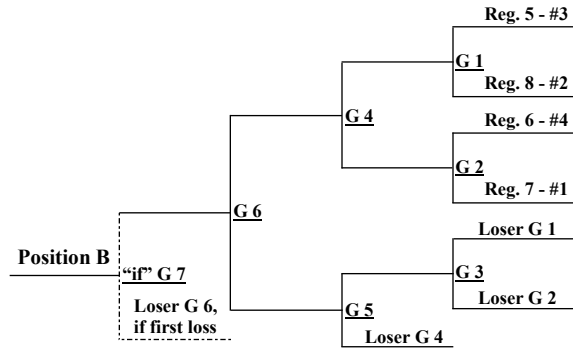
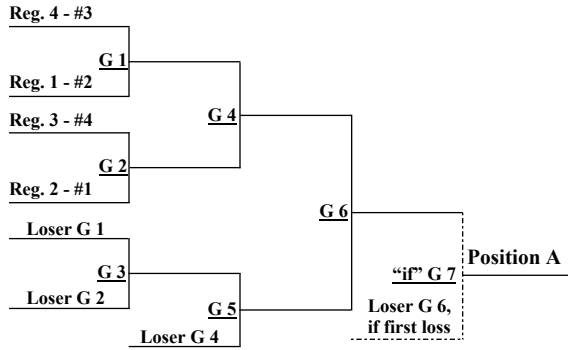

**PLAYOFF INFORMATION: The No. 1 seeds in each quadrant will host Super Regional round-robin tournaments.**



**STATE FAST PITCH SOFTBALL PLAYOFFS  
2023  
Elite Eight - All Classes**

Wednesday-Saturday, October 25-28, 2023  
Columbus Softball Complex

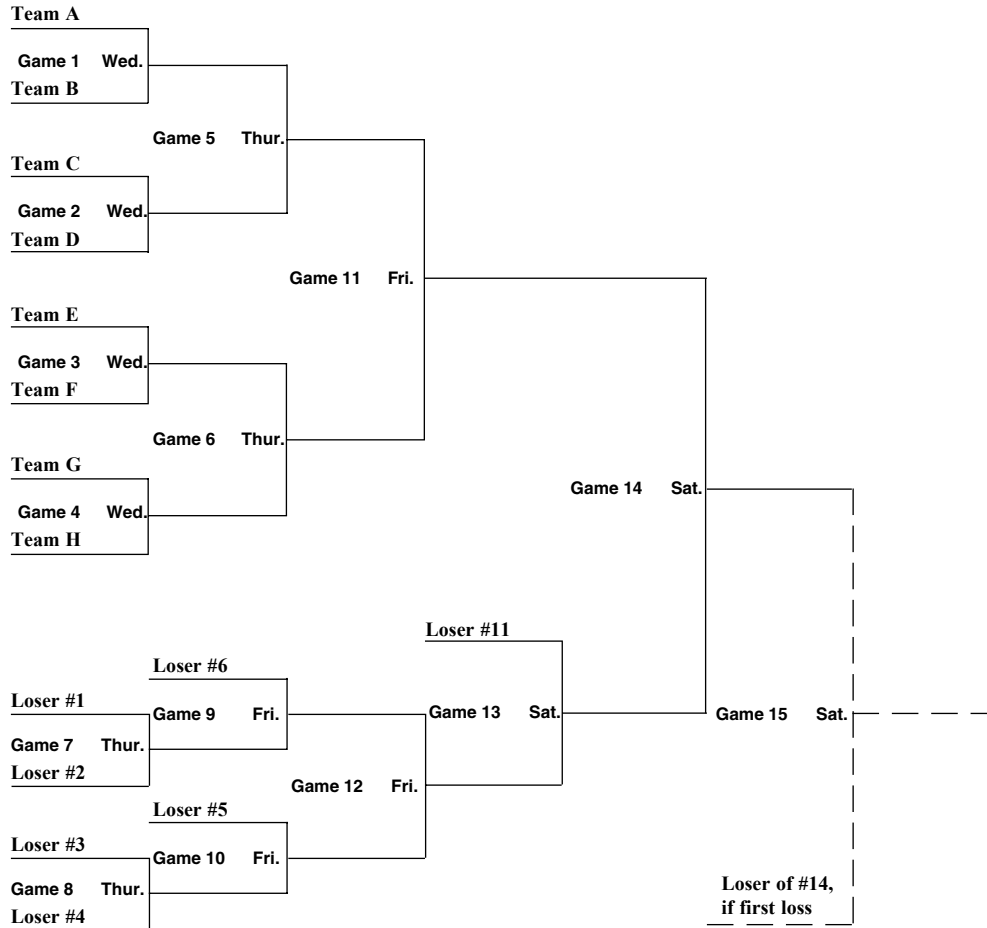

**STATE TENNIS PLAYOFFS  
2024  
Boys and Girls: All Classes**

|                          |                          |                         |                   |                          |                   |                         |                          |                          |
|--------------------------|--------------------------|-------------------------|-------------------|--------------------------|-------------------|-------------------------|--------------------------|--------------------------|
| 1st Round<br>By April 18 | 2nd Round<br>By April 24 | Quarters<br>By April 30 | Semis<br>By May 6 | Finals<br>May 11<br>Rome | Semis<br>By May 6 | Quarters<br>By April 30 | 2nd Round<br>By April 24 | 1st Round<br>By April 18 |
|--------------------------|--------------------------|-------------------------|-------------------|--------------------------|-------------------|-------------------------|--------------------------|--------------------------|



**In the first four rounds, the higher-seeded team will host. If both teams are the same seed, a “universal” GHSA coin flip will determine the host school.**

**In case of a rain-out at the State Site in the Finals, the higher-seeded team will be the host school. (The “universal” GHSA coin flip used for the Semifinal Round will determine the host school if both teams are the same seed.)**

**STATE VOLLEYBALL PLAYOFFS**  
**2023**  
**Classes 7A - 6A - 5A - 3A**



In all rounds (except neutral-site Finals), the higher-seeded team will host. If both teams are the same seed, a “universal” GHSA coin flip will determine the host school (or the designated home team in a neutral-site Final).

**STATE VOLLEYBALL PLAYOFFS  
2023  
Classes 4A - 2A - 1A**



In all rounds (except neutral-site Finals), the higher-seeded team will host. If both teams are the same seed, a “universal” GHSA coin flip will determine the host school (or the designated home team in a neutral-site Final).

# APPENDIX 'C'

## GHSA STATE OFFICERS 2023-24

President.....Jim Finch, Monroe County Schools, Forsyth  
Vice President.....Curt Miller, Oconee County High School, Watkinsville  
Executive Director.....Robin Hines, GHSA Office, Thomaston

### **REGION**

### **REGION SECRETARIES**

1- 7A.....Welton Coffey, Camden County High School, Kingsland  
2- 7A.....Brittney Jones, Pebblebrook High School, Mableton  
3- 7A.....Craig McKinney, Marietta High School  
4- 7A.....Nick Gast, Parkview High School, Lilburn  
5- 7A.....Jeremy Adams, Cherokee High School, Canton  
6- 7A.....Byron Orr, West Forsyth High School, Cumming  
7- 7A.....Mike Cammack, Norcross High School  
8- 7A.....Mike Phillips, Gwinnett County Public Schools, Suwanee  
1- 6A.....Jody Dean, Houston County School System, Perry  
2- 6A.....Steve Waters, Glynn County Schools, Brunswick  
3- 6A.....Dwayne Davis, Mundy's Mill High School, Jonesboro  
4- 6A.....Andre Regan, North Atlanta High School  
5- 6A.....Andy Dorsey, East Paulding High School, Dallas  
6- 6A.....Tonya Sebring, Cherokee County School District, Canton  
7- 6A.....Josh Mathews, Pope High School, Marietta  
8- 6A.....Nathan Turner, Forsyth County School System, Cumming  
1- 5A.....Steve Wight, Coffee School System, Douglas  
2- 5A.....Stephen Phillips, Locust Grove High School  
3- 5A.....Morgan Ingram, Northside High School, Columbus  
4- 5A.....Sharon Richard, Arabia Mountain High School, Lithonia  
5- 5A.....Reginald Curry, Jackson High School, Atlanta  
6- 5A.....Jeff Burch, Centennial High School, Roswell  
7- 5A.....Jeff McKinney, Dalton High School  
8- 5A.....Brad Bolemon, Loganville High School  
1- 4A.....Octavia Jones, Westover High School, Albany  
2- 4A.....Jeff Clayton, West Laurens High School, Dexter  
3- 4A.....Wade Marchman, Burke County High School, Waynesboro  
4- 4A.....Bill Stikes, Fayette County High School, Fayetteville  
5- 4A.....Ashley Lott, Hampton High School  
6- 4A.....Tony Watkins, Holy Innocents', Atlanta  
7- 4A.....Denise Pendley, Southeast Whitfield High School, Dalton  
8- 4A.....Sam Borg, North Hall High School, Gainesville  
1- 3A.....Bethany Wood, Crisp County High School, Cordele  
2- 3A.....Wayne Puckett, Upson-Lee High School, Thomaston  
3- 3A.....Nicholas St. Louis, St. Vincent's Academy, Savannah  
4- 3A.....Doug Connelly, Morgan County High School, Madison  
5- 3A.....Alana Allen, Douglass High School, Atlanta  
6- 3A.....Meredith Barnhill, Adairsville High School  
7- 3A.....Joe Sanfilippo, White County High School, Cleveland  
8- 3A.....Cecil Maret, Hart County High School, Hartwell  
1- 2A.....Jarrett Luke, Berrien High School, Nashville  
2- 2A.....Craig Fitts, Hamilton  
3- 2A.....Robbie Spires, Pierce County High School, Blackshear  
4- 2A.....Bernard Bowman, Glenn Hills High School, Augusta  
5- 2A.....Charlcye Henderson, Redan High School, Stone Mountain  
6- 2A.....Myss Johnson-Jelks, Atlanta Public Schools  
7- 2A.....Steve Turrentine, Rome  
8- 2A.....Randy Gambrell, Jefferson High School  
1-A Div. 2.....Jim Morrell, Ft. Gaines  
2-A Div. 2.....Scott Ray, Lanier County High School, Lakeland  
3-A Div. 2.....Justin Chester, Portal High School  
4-A Div. 2.....David Coffee, Hawkinsville High School  
5-A Div. 2.....Mandy Elder, Georgia Military College, Milledgeville  
6-A Div. 2.....Stephen Holmes, Manchester High School  
7-A Div. 2.....Chad Jordan, Christian Heritage School, Dalton  
8-A Div. 2.....Steven Simpson, Warren County High School, Warrenton  
1-A Div. 1.....Charles Perry, Brooks County High School, Quitman  
2-A Div. 1.....Jeff Clayton, East Laurens High School, East Dublin  
3-A Div. 1.....Terry Markovic, Screven County High School, Sylvania  
4-A Div. 1.....Calvin Scandrett, Crawford County High School, Roberta  
5-A Div. 1.....Randy Gambrell, Jefferson High School  
6-A Div. 1.....Andrew Tulowitzky, Galloway School, Atlanta  
7-A Div. 1.....Jeff Shiflett, Coosa High School, Rome  
8-A Div. 1.....Randy Gambrell, Jefferson High School

## STATE EXECUTIVE COMMITTEE 2023-24

| <u>REGION</u>   | <u>COMMITTEE MEMBER</u>  |
|-----------------|--|
| 1- 7A.....      | Danny Redshaw, Lowndes High School, Valdosta                     |
| 2- 7A.....      | Evan Horton, East Coweta High School, Sharpsburg                 |
| 3- 7A.....      | Don Baker, Cobb County Public Schools, Marietta                  |
| 4- 7A.....      | Jason Dopson, Brookwood High School, Snellville                  |
| 5- 7A.....      | Matthew Moody, North Cobb High School, Kennesaw                  |
| 6- 7A.....      | Nathan Turner, Forsyth County School System, Cumming             |
| 7- 7A.....      | Kirk Barton, Norcross High School                                |
| 8- 7A.....      | Jason Carrera, Central Gwinnett High School, Lawrenceville       |
| 1- 6A.....      | Jason Brett, Houston County High School, Warner Robins           |
| 2- 6A.....      | Steve Waters, Glynn County Schools, Brunswick                    |
| 3- 6A.....      | Cedric King, Lovejoy High School, Hampton                        |
| 4- 6A.....      | Todd Mooney, St. Pius X, Atlanta                                 |
| 5- 6A.....      | Willie Cannon, Hughes High School, Fairburn                      |
| 6- 6A.....      | Tonya Sebring, Cherokee County School District, Canton           |
| 7- 6A.....      | Steven Craft, Fulton County Schools, Atlanta                     |
| 8- 6A.....      | Brad Hayes, Jackson County High School, Jefferson                |
| 1- 5A.....      | Garrett Black, Greenbrier High School, Evans                     |
| 2- 5A.....      | Kelli Smith, Henry County Schools, McDonough                     |
| 3- 5A.....      | Mindy Johnson, Harris County High School, Hamilton               |
| 4- 5A.....      | James Jackson, DeKalb County School District                     |
| 5- 5A.....      | Rendell Jackson, Atlanta Public Schools                          |
| 6- 5A.....      | Peter Giles, Kell High School, Marietta                          |
| 7- 5A.....      | Darrell Demastus, Cartersville High School                       |
| 8- 5A.....      | Jeff Segars, Loganville High School                              |
| 1- 4A.....      | Jeff Battles, Muscogee County School District, Columbus          |
| 2- 4A.....      | Dexter Ricks, Baldwin High School, Milledgeville                 |
| 3- 4A.....      | Brooke Whitlock, New Hampstead High School, Bloomingdale         |
| 4- 4A.....      | Shane Ratliff, Starr's Mill High School, Fayetteville            |
| 5- 4A.....      | Andre Byrd, Stockbridge High School                              |
| 6- 4A.....      | Bobby Brewington, Monroe   |
| 7- 4A.....      | Jarred Griffis, Central-Carroll High School, Carrollton          |
| 8- 4A.....      | Michael Dowis, North Oconee High School, Bogart                  |
| 1- 3A.....      | Jeremy Rayburn, Thomasville High School                          |
| 2- 3A.....      | Greg Ellison, Peach County High School, Ft. Valley               |
| 3- 3A.....      | Reggie Wilkes, Long County High School, Ludowici                 |
| 4- 3A.....      | Lawrence Kelly, Cross Creek High School, Augusta                 |
| 5- 3A.....      | Jasper Jewell, Atlanta Public Schools                            |
| 6- 3A.....      | Ronnie Massey, LaFayette High School                             |
| 7- 3A.....      | Paul Standard, Gilmer High School, Ellijay                       |
| 8- 3A.....      | Eli Connell, Monroe Area High School, Monroe                     |
| 1- 2A.....      | Jarrett Luke, Berrien High School, Nashville                     |
| 2- 2A.....      | Kevin Grooms, Bibb County School District, Macon                 |
| 3- 2A.....      | Jesse Crews, Appling County High School, Baxley                  |
| 4- 2A.....      | Myron Newton, Butler High School, Augusta                        |
| 5- 2A.....      | Brian Montgomery, Columbia High School, Decatur                  |
| 6- 2A.....      | Joshua Moore, BEST Academy, Atlanta                              |
| 7- 2A.....      | Barry Williams, Rockmart High School                             |
| 8- 2A.....      | Kevin Petroski, Athens Academy                                   |
| 1-A Div. 1..... | Mike Thompson, Bacon County High School, Alma                    |
| 2-A Div. 1..... | Fred Williams, Dublin High School                                |
| 3-A Div. 1..... | Randy Cooper, Claxton High School                                |
| 4-A Div. 1..... | Tim Gribben, Temple High School                                  |
| 5-A Div. 1..... | Richard Ricketts, Prince Avenue Christian, Bogart                |
| 6-A Div. 1..... | Brad Dehem, Mt. Vernon School, Atlanta                           |
| 7-A Div. 1..... | Rick Hurst, Pepperell High School, Lindale                       |
| 8-A Div. 1..... | Heath Kennedy, Athens Christian School                           |
| 1-A Div. 2..... | David Bell, Baconton Charter,                                    |
| 2-A Div. 2..... | Don Tison, Clinch County High School, Homerville                 |
| 3-A Div. 2..... | Bradley Warren, McIntosh County Academy, Darien                  |
| 4-A Div. 2..... | Eli Dupree, Wheeler County, Alamo                                |
| 5-A Div. 2..... | Don Norton, Johnson County High School, Wrightsville             |
| 6-A Div. 2..... | Harley Calhoun, Schley County High School, Ellaville             |
| 7-A Div. 2..... | Chad Jordan, Christian Heritage, Dalton                          |
| 8-A Div. 2..... | Steven Simpson, Warren County High School, Warrenton             |
| At Large.....   | Jose Fernandez, Woodward Academy, College Park                   |
| At Large.....   | Michelle Masters, Peach County Schools, Ft. Valley               |
| At Large.....   | Regina Montgomery, McEachern High School, Powder Springs         |
| GDOE.....       | Richard Woods, Georgia Department of Education                   |
| GSBA.....       | David Colvard, Georgia School Boards Association                 |
| GSSA.....       | Eric Holland, Georgia School Superintendents Association         |
| GASSP.....      | Kevin Yancey, Georgia Association of Secondary School Principals |
| GACA.....       | Craig Davis, Wayne County High School, Jesup                     |
| GADA.....       | Joe Sanfilippo, White County School System, Cleveland            |

# GEORGIA HIGH SCHOOL ASSOCIATION COMMITTEES 2023-24

## Board of Trustees

(Class 7A) Nathan Turner      (Class 3A) Jasper Jewell      (At Large) Jose Fernandez      (President) Jim Finch  
(Class 6A) Steven Craft      (Class 2A) Brian Montgomery      (At Large) Michelle Masters      (Vice Pres.) Curt Miller  
(Class 5A) Kelli Smith      (A - Div. 1) Mike Thompson      (At Large) Regina Montgomery  
(Class 4A) Jeff Battles      (A - Div. 2) Steven Simpson      (At Large) Kevin Petroski

### **Baseball Committee**

Danny Redshaw  
Jason Brett  
Jeff Segars  
Dexter Ricks  
Julie Jones  
Barry Williams  
Richard Ricketts

### **Basketball Committee**

Don Baker  
Cedric King  
Todd Mooney  
Peter Giles  
Shane Ratliff  
Jasper Jewell  
Kevin Grooms  
Richard Ricketts

### **Cheerleading / Dance Committee**

Nathan Turner  
Kelli Smith  
Shane Ratliff  
Jeremy Rayburn  
Bradley Warren  
Brad Dehem  
Kevin Yancey

### **Class A Committee**

Mike Thompson  
Randy Cooper  
Brad Dehem  
David Bell  
Eli Dupree  
Harley Calhoun

### **Eligibility Committee**

Evan Horton  
Jason Brett  
Mindy Johnson  
Bobby Brewington  
Richard Woods  
David Colvard  
Eric Holland  
Kevin Yancey  
Michelle Masters  
Regina Montgomery

### **Football Committee**

Evan Horton  
Brad Hayes  
Rendell Jackson  
Jeff Battles  
Jeremy Rayburn  
Myron Newton  
Don Tison  
Steven Simpson  
Jose Fernandez

### **Flag Football Committee**

Jason Carrera  
Tonya Sebring  
Kelli Smith  
Jeff Battles  
Jasper Jewell  
Kevin Grooms  
Brad Dehem

### **Golf Committee**

Matt Moody  
Garrett Black  
Andre Byrd  
Lawrence Kelly  
Heath Kennedy  
Steve Simpson  
David Colvard

### **Gymnastics Committee**

Evan Horton  
Nathan Turner  
Kelli Smith  
Michael Dowis  
Don Norton  
Regina Montgomery

### **Lacrosse Committee**

Nathan Turner  
Brooke Whitlock  
Michael Dowis  
Kevin Petroski  
Chad Jordan  
Regina Montgomery

### **Literary / One Act Play Committee**

Matt Moody  
Jason Brett  
Jeff Segars  
Jarred Griffis  
Kevin Petroski  
Steven Simpson  
Michelle Masters

### **Officials Committee**

Kirk Barton  
Steve Waters  
Darrell Demastus  
Jasper Jewell  
Dexter Ricks  
Jesse Crews  
Craig Davis

### **Reclassification Committee**

Kirk Barton  
Danny Redshaw  
Steve Waters  
Steven Craft  
Garrett Black  
James Jackson  
Bobby Brewington  
Jeff Battles  
Jasper Jewell  
Reggie Wilkes  
Jesse Crews  
Kevin Petroski  
Richard Ricketts  
Mike Thompson  
Don Norton  
Jim Finch  
Curt Miller

### **Riflery Committee**

Evan Horton  
Brad Hayes  
Darrell Demastus  
Ronnie Massey  
Harley Calhoun

### **Soccer Committee**

Jason Dopson  
Todd Mooney  
Peter Giles  
Brooke Whitlock  
Ronnie Massey  
Joshua Moore  
Rick Hurst

### **Softball Committee**

Don Baker  
Tonya Sebring  
Garrett Black  
Brooke Whitlock  
Greg Ellison  
Barry Williams  
Don Tison

### **Sportsmanship Committee**

Kirk Barton  
Cedric King  
Willie Cannon  
James Jackson  
Bobby Brewington  
Greg Ellison  
Don Norton  
Craig Davis  
Joe Sanfilippo

### **Swimming/Diving Committee**

Jason Dopson  
Garrett Black  
Shane Ratliff  
Eli Connell  
Myron Newton  
Tim Gribben  
Jose Fernandez

### **Tennis Committee**

Jason Carrera  
Steven Craft  
Kelli Smith  
Michael Dowis  
Reggie Wilkes  
Jarrett Luke  
Mike Thompson

### **Track / Cross Country Committee**

Danny Redshaw  
Steve Waters  
Rendell Jackson  
Jeff Battles  
Jeremy Rayburn  
Myron Newton  
Steven Simpson  
Regina Montgomery

### **Volleyball Committee**

Matt Moody  
Tonya Sebring  
Peter Giles  
Dexter Ricks  
Greg Ellison  
Barry Williams  
Chad Jordan  
Michelle Masters

### **Wrestling Committee**

Jason Carrera  
Steven Craft  
Darrell Demastus  
Jarred Griffis  
Paul Standard  
Brian Montgomery  
Fred Williams  
Michelle Masters

# APPENDIX 'E'

## ELIGIBILITY REPORT INSTRUCTIONS

Items to which specific attention should be directed are:

1. GHSA Eligibility Form A and Form B, instructions, and other eligibility forms are provided to all member schools on the GHSA website.
2. The report submitted to the State Office becomes a permanent record. Care should be taken to have the information fully correct and complete. An error could seriously affect the eligibility of a student and penalize a school.
3. Online submission certifies that all data is correct and accurate.
4. Boys and girls may be listed on the same Form A, and more than one activity may be listed on the same Form A.
5. Once a student has been certified eligible in a given school year, it is not necessary to re-file that student in subsequent activities unless region rules specify differently. The GHSA office maintains that once a student has been reported and declared eligible for the school year, no further report is necessary for that student during the school year UNLESS his/her eligibility has been interrupted. There is no longer any need to submit a Form B for a previously-cleared transfer student. Transfer students are never listed on a Form A.
6. An eligibility report must be filed prior to the calendar date for the first possible **practice** in any activity. Supplemental filings may be made throughout the season. (EXCEPTION: Eligibility reports for Literary, One-Act Play and Rifley competitions are due twenty (20) calendar days before the first contest.)
7. **CERTIFICATE OF ELIGIBILITY (Non-Transfer Students) - FORM A**
  - A. All non-transfer students will be filed online on the GHSA MIS web site.
  - B. NAME: List students in alphabetical order by date of entry - ninth grade (9-10-11-12). Give the full name with the last name listed first.
  - C. DATE OF BIRTH: Give the month, day, and year of the student's birth. A student whose 19th birthday was prior to May 1 of the preceding school year, is over age and not eligible to participate. You will be assisting the student if you require a birth certificate to be presented to you for verification of age.
  - D. DATE STUDENT ENTERED 9th GRADE: Complete the month, day, and year the student took the first 9th grade class at any school. This is not necessarily the date the student first entered your school. A student will not be eligible for participation for more than eight (8) semesters from the date the student entered the ninth grade.
  - E. TOTAL UNITS EARNED PREVIOUS SEMESTER: Show the total number of units the student earned the previous semester. In order to be eligible, (beginning with the second semester of 9th grade) the student must have earned at least 2.5 units or their equivalent the semester immediately preceding participation. Place an "E" in the Units Earned column and Total Units Accumulated column for entering ninth grade students.
  - F. TOTAL UNITS ACCUMULATED: Show the total number of units the student has accumulated thus far in his high school career. To be eligible, the student must accumulate units that count towards graduation as follows:

|                     |          |
|---------------------|----------|
| END OF FIRST YEAR:  | 5 Units  |
| END OF SECOND YEAR: | 11 Units |
| END OF THIRD YEAR:  | 17 Units |
  - G. ELIGIBILITY STATUS: This column is for GHSA use only.

Students who lose eligibility for not meeting the unit requirements at the beginning of the year may regain eligibility during the school year by accumulating the units required at the end of the semester and by passing the required number of subjects the previous semester. REMINDER: Eligibility is lost or regained on the first day of the new semester.



## 8. CERTIFICATE OF ELIGIBILITY - TRANSFER STUDENTS - FORM B

- A. TRANSFER STUDENTS: FORM B MUST BE ENTERED ONLINE ON THE GHSA MIS WEB SITE. If a student has transferred to your school during the past twelve (12) months after entering 9th grade (and has not been cleared previously) complete and submit a Form B for that student. If the transfer student has been in your school one full calendar year, do not file a Form B. NOTE: Transfer students who do not meet eligibility guidelines for migrant students are eligible to participate at the sub-varsity level ONLY, provided they meet academic standards.
- B. ACADEMIC DATA: This is the same information that is required for non-transfer students on Form A.
- C. YEARS ATTENDED: List all previous schools the student attended beginning with the 9th grade.
- D. ADDRESS (PRESENT/PREVIOUS): Give full street addresses and DO NOT use post office box numbers.
- E. LIVES WITH/LIVED WITH: Use the full name(s) of the parents, step-parents, guardians, etc. With blended families it is sometimes confusing when complete names are not given.
- F. DATE STUDENT ENROLLED: Be precise as to the date the student entered your school.
- G. EXCEPTIONS: Certain situations allow a student to be eligible without a bona fide change of address. See By-Law 1.60.

### FOR THE CURRENT YEAR (2023-24):

1. A student whose birth date was prior to May 1, 2004, is over age and is not eligible.
2. A student who entered 9th grade prior to August of 2020, has exceeded eight (8) semesters and is not eligible.

## 9. CERTIFICATE OF ELIGIBILITY - FORM C

- A. STUDENTS WITH INTERRUPTED ACADEMIC ELIGIBILITY: Form C must be entered online. A student gains or loses eligibility on the first day of each semester. If the student is not eligible because he has an "Incomplete" in one or more classes, or if the student is in a Credit Recovery Program at the beginning of second semester, the student has 15 school days to become eligible. That student may not practice or compete in the interim. (see By-Law 1.58). Students who have had their academic progress interrupted need to be filed on a Form C, even if their eligibility form has been submitted previously. Be certain that the relevant portions of this form are filled out completely.

### B. FILING PROCEDURES:

1. The upper half of the Form C is to be completed just like a Form A. The numbers in the "Units Earned Previous Semester" column and the "Total Units Accumulated" column should reflect the progress made in the 15-school-day period.
2. The lower half of the Form C is to be completed according to the particular issue for the student. One portion is completed if the student was making up "Incompletes," and the other is completed if the student was involved in a "Credit Recovery Program."

If the course work is not made up in the allotted 15-school-day period for the second semester, the student is ineligible for that semester. The Principal still has the option of filing a "Hardship Application" if there are special circumstances that prevented the completion of the coursework in the 15-school-day period.

10. **MT** (magnet transfer) Forms must be entered online.
11. **HS** (home study transfer) Forms must be entered online. Directions may be found on the "forms" page under Resources on the GHSA web site.
12. All **hardships** must be entered online with supporting documents uploaded.

# APPENDIX 'F'

Game Fee Chart

**GEORGIA HIGH SCHOOL ASSOCIATION**

2023-24

| <u>Sport/Contest</u>                              | <u>Varsity</u>   | <u>Sub-Varsity</u>  | <u>State Playoffs</u>  |
|---|--|---|--|
| Baseball  | Crew of two: \$75.00<br>Crew of three: \$65.00   | \$60.00   | First Three Rounds - \$130.00<br>Semis & Finals - \$145.00   |
| Basketball  | Crew of three: \$70.00<br>Shot Clock - ½ game fee  | \$55.00   | First Three Rounds - \$160.00<br>Semifinals & Finals - \$175.00                                      |
| Cheerleading                                      | \$10.70 Per Judge (1-12 teams)<br>(Pay for a minimum 12 Teams)<br>\$8.60 Per Team for more than 12 | Same as Varsity   | \$195.00 Per Sectional<br>\$170.00 Per Session   |
| Dance   | Panel of Four (4): \$150<br>Panel of Five (5): \$125<br>(Both +\$50 for every hour over 3)         | Same as Varsity   | \$185.00 Per Session   |
| Football (crew of 6)<br>Flag Football (crew of 3) | \$120.00 Per Official<br>Clock/Chain - 1/2 Game Fee<br>Flag: \$45.00 Per Official                  | \$70.00<br>Flag - Same as Varsity   | First Three Rounds - \$160.00<br>Semifinals & Finals - \$175.00<br>Flag: \$65.00 (Chain: ½ Game Fee) |
| Gymnastics  | \$65.00/Official   |   | \$85.00/Official   |
| Lacrosse  | \$83.00/Official   | \$73.00/Official  | First Three Rounds - \$110.00<br>Semifinals & Finals - \$135.00                                      |
| Soccer  | \$83.00/Official<br>Sideline judge - 1/2 Game Fee  | \$73.00/Official  | First Three Rounds - \$460.00 (crew)<br>Semis & Finals - \$470.00 (crew)                             |
| Softball  | (FP) \$73.00/Umpire<br>(SP) \$55.00/Umpire   | \$54.00/Umpire  | Super Regionals - \$105.00<br>Elite Eight - \$115.00<br>(SP) \$70.00 Per Game                        |
| Swimming  | \$56.00 - 22 Events or Less<br>Add \$2.50 Per Heat or Diver  |   | \$125.00 Per Session   |
| Volleyball<br>(per match)                         | Best of 3 - \$55.00/Official<br>Best of 5 - \$75.00/Official<br>(Line Judge: 1/2 game fee)         | Best of 3: \$44.00/Official<br>Best of 5 - \$67.00/Official<br>(Line Judge: 1/2 game fee) | First Three Rounds - \$100.00<br>Semis & Finals - \$115.00<br>(Line Judge: 1/2 game fee)             |
| Wrestling<br>(per match)                          | Dual Match - \$86.00<br>Tri or Quad Match - \$75.00<br>Individual Match \$5.50                     | Dual Match - \$65.00<br>Individual Match - \$5.00   | Duals: \$85.00<br>Traditional: \$6.00/match  |

**Regular Season Travel Fees: (1) Official - \$30.00 (2) Officials - \$40.00 (3) Officials - \$50.00 (4+) Add \$7.00 per official.**

**NOTE:** Travel fees are based on a “per crew/per competition day” basis. Fees applied as “Travel Fees” must be used to compensate contest officials for travel-related expenses. Travel Fees may be negotiated for Invitational & Region Tournaments. Regular season travel fees for travel of more than 100 miles one way are doubled. Travel Fees for State Tournament contests are a “flat fee” of \$25.00 per official.

**The fees indicated on this chart are to be applied to all GHSA sanctioned contests and are non negotiable.**

# APPENDIX 'N'

## GUIDELINES REGARDING NAME, IMAGE AND LIKENESS (NIL)

The GHSA does not specifically prohibit students from engaging in certain commercial activities as individuals. These activities, commonly referred to as name, image and likeness (NIL), will not put a student's amateur status at risk provided the student meets all the requirements for maintaining amateur status in compliance with GHSA by-law 1.92-c and providing there is no violation of by-laws prohibiting influencing a student to attend or remain at a member school under GHSA by-law 1.70 (Recruiting/Undue Influence/Following The Coach).

A student-athlete may benefit from the use of their name, image and likeness (NIL) in compliance with GHSA by-law 1.92-c provided:

- The compensation is not contingent on specific athletic performance or achievement.
- The compensation is not provided as an incentive to enroll or remain enrolled at a specific school.
- The compensation is not provided by the school or any person acting as an agent for the school.

The following guidelines are in effect for NIL activities:

- **Intellectual property** - No "marks" may be used including, but not limited to, school logos, school name, school uniforms, school mascot, or any trademarked GHSA logo or acronyms.
- No school apparel or equipment shall be worn, which includes school name, school uniforms, school logo, school mascot or any apparel displaying trademarked GHSA logos or acronyms.
- No member school facility may be used for the purpose of name, image and likeness activities.
- No activities in conflict with a member school's local school district policy may be endorsed. (Examples include, but are not limited to, tobacco products, alcohol products and controlled substances.)
- Students and their families should seek professional guidance as to how NIL activities could impact collegiate financial aid and/or tax implications, among other issues.
- Within seven (7) calendar days after entering into any type of NIL contract/agreement, a student, or the student's parents/guardians, must notify the Principal or Athletic Director of the student's school of entering into that agreement.

# APPENDIX 'P'

## GHSA FINES STRUCTURE FOR RULES VIOLATIONS

In accordance with Section 13 of Article IV of the Constitution of the Georgia High School Association, member schools are required to abide by all the rules of the Association.

The Executive Director of the Association is empowered to make a determination as to whether a violation of GHSA rules has occurred, and to assess an appropriate penalty that may include:

1. a fine of not more than \$2,500.00 per offense, and/or
2. probation in the sport(s) in which the violation occurred, and/or
3. suspension from the Association for up to a full calendar year, and/or
4. forfeiture of games and/or contests.

Pursuant to such authority, the Georgia High School Association, by and through its Executive Director and with the approval of the GHSA Executive Committee, implements and publishes the following ranges of fines for certain designated offenses. Such fines are in addition to the other penalties set forth above. The amount of such fines and the imposition of other penalties shall be determined by the Executive Director upon consideration of the facts and circumstances of the violation and shall include, but not be limited to, the following factors:

1. Whether the violation was the result of carelessness, willfulness, or ignorance.
2. The length of time the violation continued.
3. Whether the offense was self-reported or resulted from a complaint by another school, and the extent of cooperation by school officials in the investigation of the violation.
4. The number of violations involved.
5. The result of the violation (i.e.:
  - a. injury to a person
  - b. financial gain of the offending school or financial loss to another school and the amount thereof
  - c. damage to the reputation of the GHSA
  - d. whether the violation substantially contributed to winning or losing a game or contest
6. Whether the school involved has had similar or other violations within the past three (3) years.
7. Any other factors deemed by the Executive Director to merit a more or less severe fine and/or penalty.

The list of violations set forth in this listing is not all-inclusive, and if a violation of rules occurs which is not listed herein, then the Executive Director shall have the authority to assess penalties that he deems appropriate.

In addition to the listed fines and penalties, the Executive Director may issue a severe warning to a member school which places the school on notice that further violations of GHSA rules will result in increased fines and/or penalties.

## ELIGIBILITY VIOLATIONS

| VIOLATION   | RANGE OF FINES        |
|---|-----------------------|
| Allowing a player to participate in a game without having an eligibility form filed with the GHSA [By-law 2.32]   | \$50.00 - \$500.00    |
| Allowing a player to try-out, practice, or compete without having a standardized physical examination form on file at the school. [By-laws 1.41 and 2.21] | \$250.00 - \$1,000.00 |
| Allowing a "migrant" student to participate in a varsity contest. [By-laws 1.62-1.69]   | \$200.00 - \$500.00   |
| Allowing an ineligible student to try-out, practice, or compete. [By-laws 1.51 - 1.53, 1.56 and 1.58]   | \$200.00 - \$1,000.00 |
| Allowing a student who is not eligible by the age rule or the 8-semester rule to try-out, practice, or participate. [By-law 1.30 and 1.42]                | \$300.00 - \$1,000.00 |
| Violation of the "sit-out rule" following an ejection. [By-law 2.72]  | \$200.00 - \$1,000.00 |
| Violation of the 8th-grade participation rule. [By-law 1.45]  | \$250.00 - \$750.00   |

## SPORTSMANSHIP VIOLATIONS

| VIOLATION  | RANGE OF FINES        |
|--|-----------------------|
| Have a coach or player ejected from a competition. [By-law 2.72]   | \$250.00 - \$500.00   |
| Substitutes leave the bench area to go to the area of a fight during a contest. [By-law 2.71]                                    | \$250.00 - \$1,000.00 |
| Players, coaches or administrators behave in an unsporting manner before or after a contest. [By-law 2.71(b)&(e) & 2.78]         | \$250.00 - \$1,000.00 |
| Coach or player confronting (or making contact with) official(s) or committing other unsporting acts. [By-law 2.73, 2.77 & 2.78] | \$250.00 - \$1,000.00 |
| Having players involved in a multi-player fight before, during, or after a game. [By-law 2.71(d)]                                | \$500.00 - \$1,000.00 |
| Coach or administrator removing team from a competition outside of what is allowed in playing rules. [By-law 2.71(f)]            | \$500.00 - \$1,000.00 |
| Violation of video taping rules [By-law 2.88]  | \$500.00 - \$1,000.00 |
| Make comments to the media that are critical of officiating [By-law 2.74]  | \$250.00 - \$ 500.00  |

### ADMINISTRATIVE VIOLATIONS

| VIOLATION   | RANGE OF FINES                      |
|---|-------------------------------------|
| Hold an illegal practice (i.e., during school hours, out of season, etc.) or violation of practice safety rules [By-laws 2.61, 2.62, 2.67 and 2.69] | \$500.00 - \$2,500.00               |
| Participate in an illegal or an unsanctioned competition. [By-laws 2.62, 2.64, 2.66 and 2.91]   | \$200.00 - \$1,000.00               |
| Allow an unauthorized person to coach [By-laws 2.51 and 2.52]   | \$250.00 - \$1,000.00               |
| Failure to follow GHSA procedures and deadlines [By-laws 2.27, 2.31 and 2.53]   | \$50.00 - \$250.00                  |
| Failure to keep an appointment for an eligibility appeal [By-law 2.28]  | \$100.00                            |
| Allowing a player to exceed the participation limit for that sport: [By-law 1.44]<br>Football<br>All other sports                                   | \$1,000.00<br>\$200.00 - \$1,000.00 |
| Failure to exert reasonable institution control (with players, coaches, spectators, facilities, etc.) [By-laws 2.22-2.24, 2.26 and 2.71]            | \$250.00 - \$2,500.00               |
| Failure to meet conditions of game contracts and agreements [By-laws 2.29 and 2.63] (NOTE: This could also involve restitution to offended school)  | \$250.00 - \$2,500.00               |
| Failure of coaches to attend GHSA sport rules clinics [By-law 2.54]   | \$100.00                            |
| Allowing a non-student to try out, practice or compete. [By-law 1.21]   | \$250.00 - \$2,000.00               |

### ETHICS VIOLATIONS

| VIOLATION  | RANGE OF FINES          |
|--|-------------------------|
| School personnel/boosters involved in recruiting a student for athletic purposes and/or using undue influence to gain or retain a student. [By-laws 1.71 - 1.73] | \$1,000.00 - \$2,500.00 |
| Misrepresenting facts on a GHSA document. [By-laws 2.23 and 2.24]  | \$500.00 - \$2,500.00   |
| Misrepresenting facts during a GHSA investigation. [By-laws 2.23 and 2.24]   | \$500.00 - \$2,500.00   |

### MISCELLANEOUS VIOLATIONS

| VIOLATION  | RANGE OF FINES          |
|--|-------------------------|
| Violation of financial aid rules [By-laws 1.81 - 1.83]                         | \$1,000.00 - \$2,500.00 |
| Violation of amateur standing rules [By-laws 1.90 - 1.96]                      | \$500.00 - \$2,000.00   |
| Region failing to follow GHSA procedures and deadlines [By-laws 3.20 and 3.30] | \$100.00 - \$500.00     |

# APPENDIX 'R'

## CLASSIFICATION & ALIGNMENT FOR 2023-24

(NOTE: These are Region Organizations for Football, but all member schools are included.)

NR - Indicates school playing Non-Region football schedule

\*\* - Indicates school NOT playing varsity football

|   |   |
|---|---|
| <b>7A (46 Schools, All Play Football)</b> | <b>Total All Classes - 457 Schools, 412 Football)</b> |
|---|---|

### REGION 1 - 7A: (5 Schools)

|                      | <u>FTE</u> | <u>Reclass</u> |
|----------------------|------------|----------------|
| Camden County.....   | 2578       | (2584)         |
| Colquitt County..... | 2494       | (2578)         |
| Lowndes.....         | 3079       | (3295)         |
| Richmond Hill.....   | 2452       | (2514)         |
| Valdosta.....        | 2358       | (2504)         |

### REGION 2 - 7A: (5 Schools)

|                  |      |        |
|------------------|------|--------|
| Campbell.....    | 2869 | (2883) |
| Carrollton.....  | 1715 | (2785) |
| East Coweta..... | 3274 | (3432) |
| Pebblebrook..... | 2463 | (2963) |
| Westlake.....    | 2269 | (2689) |

### REGION 3 - 7A: (5 Schools)

|                     |      |        |
|---------------------|------|--------|
| Harrison.....       | 2243 | (2605) |
| Hillgrove.....      | 2309 | (2711) |
| Marietta.....       | 2606 | (2778) |
| McEachern.....      | 2357 | (2533) |
| North Paulding..... | 2836 | (2932) |

### REGION 4 - 7A: (6 Schools)

|                     |      |        |
|---------------------|------|--------|
| Archer.....         | 3061 | (3173) |
| Brookwood.....      | 3850 | (4210) |
| Grayson.....        | 3212 | (3560) |
| Newton.....         | 2478 | (2748) |
| Parkview.....       | 3213 | (3525) |
| South Gwinnett..... | 2694 | (2784) |

### REGION 5 - 7A: (6 Schools)

|                        |      |        |
|------------------------|------|--------|
| Cherokee.....          | 2940 | (3050) |
| Kennesaw Mountain..... | 1836 | (2716) |
| North Cobb.....        | 2631 | (3127) |
| Osborne.....           | 2569 | (2921) |
| Walton.....            | 2689 | (2709) |
| Wheeler.....           | 2296 | (3126) |

### REGION 6 - 7A: (6 Schools)

|                      |      |        |
|----------------------|------|--------|
| Denmark.....         | 2391 | (2823) |
| Forsyth Central..... | 2585 | (2818) |
| Lambert.....         | 2941 | (3269) |
| Milton.....          | 2153 | (2319) |
| South Forsyth.....   | 2355 | (2681) |
| West Forsyth.....    | 2406 | (2900) |

### REGION 7 - 7A: (7 Schools)

|                      |      |        |
|----------------------|------|--------|
| Berkmar.....         | 2981 | (3067) |
| Discovery.....       | 2856 | (2892) |
| Duluth.....          | 2675 | (2897) |
| Meadowcreek.....     | 2566 | (2626) |
| Norcross.....        | 2675 | (2945) |
| North Gwinnett.....  | 3087 | (3171) |
| Peachtree Ridge..... | 3313 | (3479) |

### REGION 8 - 7A: (6 Schools)

|                       |      |        |
|-----------------------|------|--------|
| Buford.....           | 1784 | (2504) |
| Central Gwinnett..... | 2378 | (2848) |
| Collins Hill.....     | 2771 | (2889) |
| Dacula.....           | 2487 | (2617) |
| Mill Creek.....       | 3812 | (3896) |
| Mountain View.....    | 2850 | (3216) |

## **6A (58 Schools, 57 Play Football)**

### REGION 1 - 6A: (6 Schools)

|                               |      |        |
|-------------------------------|------|--------|
| Houston County.....           | 2064 | (2464) |
| Lee County.....               | 1946 | (1946) |
| Northside, Warner Robins..... | 1950 | (2266) |
| Thomas County Central.....    | 1465 | (2175) |
| Tift County.....              | 2271 | (2445) |
| Veterans.....                 | 1849 | (2001) |

### REGION 2 - 6A: (7 Schools)

|                       |      |        |
|-----------------------|------|--------|
| Brunswick.....        | 1902 | (2184) |
| Effingham County..... | 2040 | (2180) |
| Evans.....            | 1903 | (1955) |
| Glynn Academy.....    | 1847 | (2117) |
| Grovetown.....        | 2129 | (2175) |
| Lakeside-Evans.....   | 1978 | (2070) |
| South Effingham.....  | 1839 | (2057) |

### REGION 3 - 6A: (8 Schools)

|                       |      |        |
|-----------------------|------|--------|
| Alcovy.....           | 1966 | (2026) |
| Forest Park.....      | 1784 | (2086) |
| Jonesboro.....        | 1423 | (2171) |
| Lovejoy.....          | 2080 | (2174) |
| Morrow.....           | 1939 | (2023) |
| Mundy's Mill.....     | 1684 | (2036) |
| Rockdale County.....  | 2309 | (3093) |
| Woodward Academy..... | 1076 | (3116) |

# CLASSIFICATION & ALIGNMENT FOR 2023-24

## REGION 4 - 6A: (7 Schools)

|                       |      |        |
|-----------------------|------|--------|
| Dunwoody.....         | 2142 | (2154) |
| Lakeside, DeKalb..... | 2174 | (2318) |
| Marist.....           | 800  | (1962) |
| North Atlanta.....    | 2218 | (2298) |
| Riverwood.....        | 1727 | (2095) |
| South Cobb.....       | 1997 | (2437) |
| St. Pius.....         | 1096 | (3216) |

## REGION 5 - 6A: (8 Schools)

|                      |      |        |
|----------------------|------|--------|
| Alexander.....       | 1911 | (2425) |
| Douglas County.....  | 1989 | (2419) |
| East Paulding.....   | 1893 | (2503) |
| Hughes.....          | 1893 | (1945) |
| New Manchester.....  | 1805 | (1965) |
| Newnan.....          | 2281 | (2393) |
| Paulding County..... | 1932 | (2410) |
| South Paulding.....  | 1922 | (2414) |

## REGION 6 - 6A: (7 Schools)

|                  |      |        |
|------------------|------|--------|
| Allatoona.....   | 1747 | (2073) |
| Creekview.....   | 2060 | (2168) |
| Etowah.....      | 2449 | (2539) |
| River Ridge..... | 1928 | (2042) |
| Rome.....        | 2037 | (2389) |
| Sequoyah.....    | 2087 | (2247) |
| Woodstock.....   | 2151 | (2237) |

## REGION 7 - 6A: (8 Schools)

|                           |      |        |
|---------------------------|------|--------|
| Alpharetta.....           | 2198 | (2270) |
| Blessed Trinity.....      | 978  | (2478) |
| Johns Creek.....          | 1967 | (1987) |
| Lassiter.....             | 1945 | (2279) |
| Pope.....                 | 1855 | (2031) |
| Roswell.....              | 2157 | (2185) |
| Sprayberry.....           | 1890 | (2178) |
| **Innovation Academy..... | 855  | (2235) |

## REGION 8 - 6A: (7 Schools)

|                        |      |        |
|------------------------|------|--------|
| Apalachee.....         | 1910 | (1990) |
| Gainesville.....       | 2290 | (2382) |
| Habersham Central..... | 2049 | (2053) |
| Jackson County.....    | 1613 | (1697) |
| Lanier.....            | 1940 | (2014) |
| North Forsyth.....     | 2151 | (2455) |
| Shiloh.....            | 2249 | (2375) |

---

## 5A (54 Schools, All Play Football)

---

## REGION 1 - 5A: (6 Schools)

|                         |      |        |
|-------------------------|------|--------|
| Bradwell Institute..... | 1689 | (1739) |
| Coffee.....             | 1724 | (1764) |
| Greenbrier.....         | 1748 | (1776) |
| Jenkins.....            | 1011 | (1579) |
| Statesboro.....         | 1797 | (1797) |
| Ware County.....        | 1627 | (1641) |

## REGION 2 - 5A: (7 Schools)

|                      |      |        |
|----------------------|------|--------|
| Dutchtown.....       | 1774 | (1932) |
| Eagle's Landing..... | 1560 | (1752) |
| Jones County.....    | 1602 | (1628) |
| Locust Grove.....    | 1619 | (1857) |
| Ola.....             | 1758 | (1872) |
| Union Grove.....     | 1592 | (1880) |
| Warner Robins.....   | 1753 | (1851) |

## REGION 3 - 5A: (5 Schools)

|                          |      |        |
|--------------------------|------|--------|
| Drew.....                | 1663 | (1837) |
| Harris County.....       | 1677 | (1725) |
| McIntosh.....            | 1719 | (1767) |
| Northgate.....           | 1776 | (1856) |
| Northside, Columbus..... | 1425 | (1843) |

## REGION 4 - 5A: (7 Schools)

|                      |      |        |
|----------------------|------|--------|
| Arabia Mountain..... | 1128 | (1128) |
| Chamblee.....        | 1789 | (1913) |
| Decatur.....         | 1732 | (1878) |
| Lithonia.....        | 1522 | (1568) |
| M.L. King.....       | 1472 | (1574) |
| Tucker.....          | 1606 | (1866) |
| NR - Cross Keys..... | 1675 | (1681) |

## REGION 5 - 5A: (9 Schools)

|                       |      |        |
|-----------------------|------|--------|
| Banneker.....         | 1595 | (1807) |
| Chapel Hill.....      | 1515 | (2081) |
| Creekside.....        | 1729 | (1731) |
| Jackson, Atlanta..... | 1494 | (1674) |
| Lithia Springs.....   | 1546 | (1782) |
| Mays.....             | 1268 | (1328) |
| Tri-Cities.....       | 1499 | (1855) |
| Villa Rica.....       | 1676 | (1790) |
| NR - Midtown.....     | 1545 | (1589) |

## REGION 6 - 5A: (7 Schools)

|                                |      |        |
|--------------------------------|------|--------|
| Cambridge.....                 | 1826 | (1886) |
| Centennial.....                | 1799 | (1875) |
| Chattahoochee.....             | 1856 | (1904) |
| Greater Atlanta Christian..... | 634  | (1874) |
| Kell.....                      | 1496 | (1926) |
| North Springs.....             | 1332 | (1744) |
| Northview.....                 | 1752 | (1814) |

## REGION 7 - 5A: (6 Schools)

|                             |      |        |
|-----------------------------|------|--------|
| Calhoun.....                | 1248 | (1740) |
| Cartersville.....           | 1422 | (1944) |
| Cass.....                   | 1519 | (1615) |
| Dalton.....                 | 1761 | (1891) |
| Hiram.....                  | 1458 | (1628) |
| Woodland, Cartersville..... | 1461 | (1623) |



# CLASSIFICATION & ALIGNMENT FOR 2023-24

## REGION 8 - 5A: (7 Schools)

|                       |      |        |
|-----------------------|------|--------|
| Clarke Central.....   | 1833 | (1909) |
| Eastside.....         | 1611 | (1807) |
| Flowery Branch.....   | 1318 | (1738) |
| Heritage-Conyers..... | 1852 | (1912) |
| Jefferson.....        | 1189 | (1633) |
| Loganville.....       | 1803 | (1907) |
| Winder-Barrow.....    | 1846 | (1928) |

---

## **4A (60 Schools, All Play Football)**

---

## REGION 1 - 4A: (5 Schools)

|                 |      |        |
|-----------------|------|--------|
| Bainbridge..... | 1352 | (1374) |
| Cairo.....      | 1288 | (1326) |
| Hardaway.....   | 1204 | (1522) |
| Shaw.....       | 1179 | (1505) |
| Westover.....   | 1351 | (1453) |

## REGION 2 - 4A: (7 Schools)

|                     |      |        |
|---------------------|------|--------|
| Baldwin.....        | 1272 | (1272) |
| Griffin.....        | 1485 | (1521) |
| Howard.....         | 1115 | (1285) |
| Perry.....          | 1457 | (1605) |
| Spalding.....       | 1260 | (1336) |
| West Laurens.....   | 1273 | (1457) |
| Westside-Macon..... | 1011 | (1289) |

## REGION 3 - 4A: (6 Schools)

|                        |      |        |
|------------------------|------|--------|
| Benedictine.....       | 0816 | (1472) |
| Burke County.....      | 1214 | (1300) |
| Islands.....           | 0929 | (1461) |
| New Hampstead.....     | 1349 | (1399) |
| Southeast Bulloch..... | 1161 | (1313) |
| Wayne County.....      | 1425 | (1425) |

## REGION 4 - 4A: (8 Schools)

|                        |      |        |
|------------------------|------|--------|
| Fayette County.....    | 1340 | (1408) |
| LaGrange.....          | 1266 | (1362) |
| North Clayton.....     | 1234 | (1432) |
| Riverdale.....         | 1435 | (1583) |
| Starr's Mill.....      | 1343 | (1577) |
| Trinity Christian..... | 0497 | (1059) |
| Troup.....             | 1314 | (1432) |
| Whitewater.....        | 1338 | (1566) |

## REGION 5 - 4A: (8 Schools)

|                            |      |        |
|----------------------------|------|--------|
| Hampton.....               | 1262 | (1336) |
| Lovett.....                | 0685 | (1295) |
| Luella.....                | 1402 | (1518) |
| McDonough.....             | 1234 | (1304) |
| Mt. Zion, Jonesboro.....   | 1312 | (1514) |
| Pace Academy.....          | 0495 | (0997) |
| Stockbridge.....           | 1531 | (1531) |
| Woodland, Stockbridge..... | 1401 | (1439) |

## REGION 6 - 4A: (9 Schools)

|                          |      |        |
|--------------------------|------|--------|
| Hapeville.....           | 0661 | (1555) |
| Holy Innocents'.....     | 0580 | (1384) |
| Miller Grove.....        | 1206 | (1350) |
| Southwest DeKalb.....    | 1291 | (1475) |
| Stephenson.....          | 1356 | (1468) |
| Westminster.....         | 0825 | (1459) |
| NR - Clarkston.....      | 1421 | (1531) |
| NR - Druid Hills.....    | 1340 | (1560) |
| NR - Stone Mountain..... | 1220 | (1356) |

## REGION 7 - 4A: (6 Schools)

|                          |      |        |
|--------------------------|------|--------|
| Cedartown.....           | 1361 | (1393) |
| Central, Carroll.....    | 1192 | (1460) |
| Heritage, Catoosa.....   | 1280 | (1332) |
| Northwest Whitfield..... | 1266 | (1528) |
| Sonoraville.....         | 1152 | (1266) |
| Southeast Whitfield..... | 1458 | (1510) |

## REGION 8 - 4A: (11 Schools)

|                               |      |                  |
|-------------------------------|------|------------------|
| Cedar Shoals.....             | 1509 | (1551)           |
| Cherokee Bluff.....           | 1057 | (1305)           |
| Chestatee.....                | 1266 | (1342)           |
| East Forsyth.....             | 1069 | (1165)           |
| East Hall.....                | 1259 | (1325)           |
| Madison County.....           | 1394 | (1406)           |
| North Hall.....               | 1138 | (1324)           |
| North Oconee.....             | 1512 | (1534)           |
| Walnut Grove.....             | 1426 | (1568)           |
| NR - Johnson-Gainesville..... | 1340 | (1536)           |
| NR - Seckinger.....           | 1288 | (1288) Projected |

---

## **3A (51 Schools, 50 Football)**

---

## REGION 1 - 3A: (6 Schools)

|                      |      |        |
|----------------------|------|--------|
| Carver-Columbus..... | 0865 | (1243) |
| Columbus.....        | 1171 | (1217) |
| Crisp County.....    | 1070 | (1154) |
| Dougherty.....       | 1121 | (1243) |
| Monroe.....          | 1117 | (1227) |
| Thomasville.....     | 0771 | (1073) |

## REGION 2 - 3A: (5 Schools)

|                   |      |        |
|-------------------|------|--------|
| Jackson.....      | 1078 | (1082) |
| Mary Persons..... | 1190 | (1218) |
| Peach County..... | 1045 | (1045) |
| Pike County.....  | 1078 | (1080) |
| Upson-Lee.....    | 1195 | (1205) |

# CLASSIFICATION & ALIGNMENT FOR 2023-24

**REGION 3 - 3A:** (9 Schools)

|                           |      |        |
|---------------------------|------|--------|
| Beach.....                | 0915 | (1145) |
| Calvary Day.....          | 0367 | (0929) |
| Groves.....               | 0884 | (1148) |
| Johnson, Savannah.....    | 0746 | (1322) |
| Liberty County.....       | 1081 | (1133) |
| Long County.....          | 1144 | (1158) |
| Savannah Christian.....   | 0421 | (1209) |
| Savannah Country Day..... | 0359 | (0995) |
| ** St. Vincent's.....     | 0582 | (1140) |

**REGION 4 - 3A:** (6 Schools)

|                       |      |        |
|-----------------------|------|--------|
| Cross Creek.....      | 1157 | (1271) |
| Harlem.....           | 1169 | (1205) |
| Hephzibah.....        | 1014 | (1182) |
| Morgan County.....    | 1048 | (1104) |
| Richmond Academy..... | 1096 | (1388) |
| Salem.....            | 1138 | (1212) |

**REGION 5 - 3A:** (4 Schools)

|                        |      |        |
|------------------------|------|--------|
| Carver, Atlanta.....   | 0992 | (1016) |
| Cedar Grove.....       | 1167 | (1191) |
| Douglass, Atlanta..... | 1182 | (1252) |
| Sandy Creek.....       | 1155 | (1249) |

**REGION 6 - 3A:** (8 Schools)

|                              |      |        |
|------------------------------|------|--------|
| Adairsville.....             | 1089 | (1169) |
| Bremen.....                  | 0733 | (1167) |
| Coahulla Creek.....          | 1031 | (1163) |
| Gordon Lee.....              | 0428 | (0972) |
| LaFayette.....               | 1126 | (1160) |
| Lakeview-Ft. Oglethorpe..... | 1063 | (1131) |
| Ridgeland.....               | 1267 | (1277) |
| Ringgold.....                | 1058 | (1218) |

**REGION 7 - 3A:** (7 Schools)

|                     |      |        |
|---------------------|------|--------|
| Dawson County.....  | 1126 | (1154) |
| Gilmer.....         | 1208 | (1208) |
| Lumpkin County..... | 1130 | (1140) |
| Pickens.....        | 1260 | (1266) |
| Wesleyan.....       | 0497 | (1167) |
| West Hall.....      | 1186 | (1284) |
| White County.....   | 1183 | (1213) |

**REGION 8 - 3A:** (6 Schools)

|                       |      |        |
|-----------------------|------|--------|
| Franklin County.....  | 1067 | (1079) |
| Hart County.....      | 1064 | (1098) |
| Hebron Christian..... | 0438 | (1164) |
| Monroe Area.....      | 1097 | (1107) |
| Oconee County.....    | 1246 | (1260) |
| Stephens County.....  | 1104 | (1114) |

---

**2A (65 Schools, 58 Football)**

---

**REGION 1 - 2A:** (7 Schools)

|                    |      |        |
|--------------------|------|--------|
| Berrien.....       | 0845 | (0885) |
| Cook.....          | 0890 | (0930) |
| Dodge County.....  | 0838 | (0854) |
| Fitzgerald.....    | 0838 | (0874) |
| Jeff Davis.....    | 0842 | (0874) |
| Sumter County..... | 1025 | (1037) |
| Worth County.....  | 0834 | (0874) |

**REGION 2 - 2A:** (8 Schools)

|                      |      |        |
|----------------------|------|--------|
| ACE Charter.....     | 0504 | (0984) |
| Central-Macon.....   | 0827 | (1371) |
| Jordan.....          | 0887 | (1071) |
| Kendrick.....        | 0925 | (1005) |
| Northeast-Macon..... | 0724 | (0794) |
| Rutland.....         | 0880 | (0970) |
| Southwest-Macon..... | 0779 | (0793) |
| Spencer.....         | 0929 | (1091) |

**REGION 3 - 2A:** (8 Schools)

|                       |      |        |
|-----------------------|------|--------|
| Appling County.....   | 1028 | (1040) |
| Brantley County.....  | 0931 | (0951) |
| Pierce County.....    | 1034 | (1044) |
| Tattnall County.....  | 1005 | (1035) |
| Toombs County.....    | 0809 | (0899) |
| Vidalia.....          | 0760 | (1064) |
| Windsor-Forest.....   | 0982 | (1024) |
| ** Savannah Arts..... | 0913 | (0919) |

**REGION 4 - 2A:** (11 Schools)

|                                 |      |        |
|---------------------------------|------|--------|
| Butler.....                     | 0770 | (0864) |
| Glenn Hills.....                | 0871 | (0893) |
| Josey.....                      | 0692 | (0708) |
| Laney.....                      | 0665 | (0895) |
| Putnam County.....              | 0860 | (0866) |
| Thomson.....                    | 0984 | (0986) |
| Washington County.....          | 0881 | (0891) |
| Westside, Augusta.....          | 0906 | (1004) |
| ** Davidson Fine Arts.....      | 0415 | (0415) |
| ** Johnson-Augusta.....         | 0348 | (0348) |
| ** Technical Career Magnet..... | 0282 | (0282) |

**REGION 5 - 2A:** (8 Schools)

|                         |      |        |
|-------------------------|------|--------|
| Callaway.....           | 0895 | (0965) |
| Columbia.....           | 0985 | (1003) |
| ELCA.....               | 0337 | (0891) |
| Landmark Christian..... | 0347 | (0995) |
| McNair.....             | 0776 | (0776) |
| Redan.....              | 0932 | (0952) |
| Towers.....             | 0795 | (0807) |
| ** Elite Scholars.....  | 0366 | (0372) |

# CLASSIFICATION & ALIGNMENT FOR 2023-24

## REGION 6 - 2A: (10 Schools)

|                           |      |        |
|---------------------------|------|--------|
| B.E.S.T. Academy.....     | 0336 | (0336) |
| KIPP Atlanta.....         | 0803 | (2047) |
| Mt. Paran.....            | 0444 | (0680) |
| North Cobb Christian..... | 0371 | (1039) |
| South Atlanta.....        | 0857 | (0921) |
| Therrell.....             | 1003 | (1055) |
| Washington.....           | 0862 | (0922) |
| NR - Walker.....          | 0338 | (0944) |
| ** Coretta S. King.....   | 0362 | (0362) |
| ** Drew Charter.....      | 0493 | (0535) |

## REGION 7 - 2A: (7 Schools)

|                      |      |        |
|----------------------|------|--------|
| Fannin County.....   | 0893 | (0893) |
| Gordon Central.....  | 0848 | (0968) |
| Haralson County..... | 0947 | (0949) |
| Model.....           | 0712 | (0998) |
| Murray County.....   | 1059 | (1069) |
| North Murray.....    | 0997 | (1055) |
| Rockmart.....        | 0956 | (0964) |

## REGION 8 - 2A: (6 Schools)

|                           |      |        |
|---------------------------|------|--------|
| Athens Academy.....       | 0350 | (0912) |
| Banks County.....         | 0886 | (0886) |
| East Jackson.....         | 0984 | (1002) |
| Fellowship Christian..... | 0389 | (0849) |
| Providence Christian..... | 0306 | (0914) |
| Union County.....         | 0915 | (0975) |

---

## **A - Division 1 (48 Schools, 38 Football)**

---

### REGION 1 - A, Division 1: (4 Schools)

|                    |     |       |
|--------------------|-----|-------|
| Bacon County.....  | 604 | (628) |
| Brooks County..... | 524 | (580) |
| Irwin County.....  | 484 | (508) |
| Pelham.....        | 432 | (932) |

### REGION 2 - A, Division 1: (5 Schools)

|                       |     |       |
|-----------------------|-----|-------|
| Bleckley County.....  | 652 | (798) |
| Dublin.....           | 544 | (652) |
| East Laurens.....     | 664 | (710) |
| Jefferson County..... | 651 | (655) |
| Swainsboro.....       | 779 | (781) |

### REGION 3 - A, Division 1: (6 Schools)

|                            |     |       |
|----------------------------|-----|-------|
| Bryan County.....          | 598 | (606) |
| Claxton.....               | 524 | (548) |
| Metter.....                | 452 | (504) |
| Savannah.....              | 635 | (695) |
| Screven County.....        | 576 | (586) |
| ** Woodville-Tompkins..... | 663 | (663) |

### REGION 4 - A, Division 1: (4 Schools)

|                      |     |       |
|----------------------|-----|-------|
| Crawford County..... | 529 | (545) |
| Heard County.....    | 647 | (731) |
| Lamar County.....    | 819 | (861) |
| Temple.....          | 674 | (738) |

### REGION 5 - A, Division 1: (5 Schools)

|                              |     |       |
|------------------------------|-----|-------|
| Jasper County.....           | 650 | (654) |
| Oglethorpe County.....       | 611 | (627) |
| Prince Avenue Christian..... | 289 | (693) |
| Social Circle.....           | 591 | (817) |
| ** Stillwell Arts.....       | 534 | (576) |

### REGION 6 - A, Division 1: (10 Schools)

|                               |     |        |
|-------------------------------|-----|--------|
| Mt. Vernon.....               | 456 | (1168) |
| Mt. Pisgah.....               | 275 | (533)  |
| St. Francis.....              | 281 | (817)  |
| Whitefield Academy.....       | 310 | (844)  |
| NR - King's Ridge.....        | 275 | (587)  |
| ** Atlanta International..... | 391 | (753)  |
| ** Galloway.....              | 327 | (591)  |
| ** Mt. Bethel.....            | 144 | (422)  |
| ** Paideia.....               | 465 | (765)  |
| ** Weber School.....          | 271 | (747)  |

### REGION 7 - A, Division 1: (8 Schools)

|                        |     |       |
|------------------------|-----|-------|
| Armuchee.....          | 509 | (659) |
| Chattooga.....         | 677 | (713) |
| Coosa.....             | 658 | (764) |
| Dade County.....       | 621 | (631) |
| Darlington.....        | 562 | (834) |
| Pepperell.....         | 730 | (854) |
| Trion.....             | 381 | (881) |
| ** Dalton Academy..... | 617 | (625) |

### REGION 8 - A, Division 1: (6 Schools)

|                        |     |       |
|------------------------|-----|-------|
| Athens Christian.....  | 224 | (570) |
| Commerce.....          | 489 | (767) |
| Elbert County.....     | 818 | (824) |
| Rabun County.....      | 657 | (687) |
| ** Barrow Academy..... | 611 | (617) |
| ** Tallulah Falls..... | 351 | (765) |

# CLASSIFICATION & ALIGNMENT FOR 2023-24

## A - Division 2 (75 Schools, 49 Football)

### REGION 1 - A, Division 2: (13 Schools)

|                                |     |                 |
|--------------------------------|-----|-----------------|
| Baconton.....                  | 225 | (315)           |
| Early County.....              | 559 | (637)           |
| Miller County.....             | 251 | (297)           |
| Mitchell County.....           | 346 | (362)           |
| Randolph-Clay.....             | 263 | (263)           |
| Seminole County.....           | 423 | (537)           |
| Terrell County.....            | 312 | (312)           |
| NR - Pataula Charter.....      | 171 | (397)           |
| ** Baker County.....           | 077 | (099)           |
| ** Calhoun County.....         | 168 | (168)           |
| ** Quitman County.....         | 089 | (089)           |
| ** Southwest Georgia STEM..... | 055 | (127) Projected |
| ** Stewart County.....         | 122 | (124)           |

### REGION 2 - A, Division 2: (6 Schools)

|                       |     |       |
|-----------------------|-----|-------|
| Atkinson County.....  | 440 | (496) |
| Charlton County.....  | 435 | (445) |
| Clinch County.....    | 317 | (337) |
| Lanier County.....    | 446 | (464) |
| Turner County.....    | 339 | (339) |
| ** Echols County..... | 233 | (267) |

### REGION 3 - A, Division 2: (8 Schools)

|                                |     |       |
|--------------------------------|-----|-------|
| Emanuel County Institute.....  | 330 | (434) |
| Jenkins County.....            | 316 | (316) |
| McIntosh County Academy.....   | 385 | (385) |
| Montgomery County.....         | 288 | (308) |
| Portal.....                    | 270 | (282) |
| ** Savannah Classical.....     | 064 | (064) |
| ** Savannah Early College..... | 170 | (170) |
| ** Steam Academy.....          | 086 | (086) |

### REGION 4 - A, Division 2: (6 Schools)

|                     |     |       |
|---------------------|-----|-------|
| Dooly County.....   | 310 | (316) |
| Hawkinsville.....   | 350 | (414) |
| Telfair County..... | 414 | (422) |
| Treutlen.....       | 274 | (302) |
| Wheeler County..... | 265 | (319) |
| Wilcox County.....  | 345 | (371) |

### REGION 5 - A, Division 2: (7 Schools)

|                                   |     |       |
|-----------------------------------|-----|-------|
| Georgia Military College.....     | 316 | (472) |
| Glascock County.....              | 170 | (170) |
| Hancock Central.....              | 245 | (245) |
| Johnson County.....               | 316 | (344) |
| Twiggs County.....                | 206 | (208) |
| Wilkinson County.....             | 378 | (378) |
| ** Georgia Academy for Blind..... | 055 | (055) |

### REGION 6 - A, Division 2: (11 Schools)

|                           |     |       |
|---------------------------|-----|-------|
| Central-Talbotton.....    | 131 | (131) |
| Chattahoochee County..... | 471 | (527) |
| Greenville.....           | 264 | (264) |
| Macon County.....         | 359 | (359) |
| Manchester.....           | 405 | (417) |
| Marion County.....        | 382 | (388) |
| Schley County.....        | 401 | (577) |
| Taylor County.....        | 366 | (406) |
| ** Furlow Charter.....    | 140 | (140) |
| ** Rainey-McCullers.....  | 166 | (188) |
| ** Webster County.....    | 066 | (080) |

### REGION 7 - A, Division 2: (14 Schools)

|                                   |     |                 |
|-----------------------------------|-----|-----------------|
| Bowdon.....                       | 395 | (425)           |
| Christian Heritage.....           | 194 | (426)           |
| Mt. Zion-Carroll.....             | 450 | (498)           |
| ** Atlanta Classical.....         | 192 | (240)           |
| ** Ben Franklin.....              | 092 | (250)           |
| ** DeKalb School for Arts.....    | 327 | (327)           |
| ** Fulton Leadership Academy..... | 226 | (260)           |
| ** Genesis Innovative.....        | 056 | (056) Projected |
| ** Georgia School for Deaf.....   | 107 | (107)           |
| ** Greenforest Christian.....     | 052 | (072)           |
| ** SW Atlanta Christian.....      | 100 | (120)           |
| ** Utopian Academy.....           | 275 | (275) Projected |
| ** W.D. Mohammed.....             | 045 | (115)           |
| ** Woody Gap.....                 | 020 | (022)           |

### REGION 8 - A, Division 2: (10 Schools)

|                                |     |                 |
|--------------------------------|-----|-----------------|
| Aquinas.....                   | 219 | (479)           |
| Greene County.....             | 409 | (411)           |
| Lincoln County.....            | 349 | (357)           |
| Towns County.....              | 303 | (303)           |
| Warren County.....             | 159 | (161)           |
| Washington-Wilkes.....         | 385 | (385)           |
| NR - GSIC.....                 | 203 | (203)           |
| NR - Lake Oconee Academy.....  | 263 | (263)           |
| ** Georgia Fugees Academy..... | 050 | (050) Projected |
| ** Taliaferro County.....      | 049 | (061)           |

**NOTE:** The first enrollment figure shown beside each member school is the FTE count in grades 9-12, while the second in ( ) is the Student Reclassification Count after applying the 3.0 multiplier to out-of-district students.

\*\* - Schools not playing varsity football.

NR - Schools playing a non-region schedule in football.

# APPENDIX 'S'

## STUDENT TRANSFER SERVICE AREAS FOR NON-PUBLIC & CHARTER MEMBER SCHOOLS

(The Student Transfer Service Area for non-public and charter member schools is the same as the public school service area in which the non-public or charter school resides.)

| <b>SCHOOL.....</b>              | <b>SERVICE AREA</b>  |
|---------------------------------|----------------------|
| ACE Charter.....                | Howard HS            |
| Aquinas.....                    | Richmond Academy     |
| Athens Academy.....             | Oconee County HS     |
| Athens Christian.....           | Cedar Shoals HS      |
| Atlanta Classical Charter.....  | North Atlanta HS     |
| Atlanta International.....      | North Atlanta HS     |
| Baconton Charter.....           | Mitchell County HS   |
| Ben Franklin (Boarding) .....   | Druid Hills HS       |
| Benedictine.....                | Jenkins HS           |
| Blessed Trinity.....            | Roswell HS           |
| Calvary Day School.....         | Jenkins HS           |
| Christian Heritage.....         | Dalton HS            |
| Darlington.....                 | Rome HS              |
| Drew Charter.....               | Jackson-Atlanta HS   |
| ELCA.....                       | Eagles Landing HS    |
| Fellowship Christian.....       | Roswell HS           |
| Fulton Leadership Charter.....  | Tri-Cities HS        |
| Furlow Charter.....             | Sumter County HS     |
| Galloway.....                   | Riverwood HS         |
| Genesis Innovative Academy..... | Douglass HS          |
| Georgia Fugees Academy.....     | Tucker HS            |
| Greater Atlanta Christian ..... | Meadowcreek HS       |
| Greenforest Christian .....     | Columbia HS          |
| GSIC Charter.....               | Hephzibah HS         |
| Hapeville Charter.....          | Banneker HS          |
| Hebron Christian.....           | Dacula HS            |
| Holy Innocents'.....            | Riverwood HS         |
| King's Ridge Christian.....     | Cambridge HS         |
| KIPP Atlanta Charter.....       | Douglass HS          |
| Lake Oconee Academy.....        | Greene County HS     |
| Landmark Christian.....         | Creekside HS         |
| Lovett.....                     | North Atlanta HS     |
| Marist.....                     | Chamblee HS          |
| Mt. Bethel.....                 | Sprayberry HS        |
| Mt. Paran Christian.....        | Kennesaw Mountain HS |
| Mt. Pisgah Christian.....       | Centennial HS        |

| <b>SCHOOL.....</b>              | <b>SERVICE AREA</b>  |
|---------------------------------|----------------------|
| Mt. Vernon School.....          | North Springs HS     |
| North Cobb Christian.....       | North Cobb HS        |
| NW Classical Ac. (2024-25)...   | North Cobb HS        |
| Pace Academy.....               | North Atlanta HS     |
| Paideia.....                    | Druid Hills HS       |
| Pataula Charter.....            | Calhoun County HS    |
| Prince Avenue Christian .....   | North Oconee HS      |
| Providence Christian.....       | Berkmar HS           |
| St. Francis.....                | Cambridge HS         |
| St. Pius X.....                 | Cross Keys HS        |
| St. Vincent's Academy.....      | Savannah HS          |
| Savannah Christian.....         | Groves HS            |
| Savannah Classical.....         | Savannah HS          |
| Savannah Country Day.....       | Windsor Forest HS    |
| SW Atlanta Christian.....       | Therrell HS          |
| SW Georgia STEM.....            | Randolph-Clay HS     |
| STEAM Academy Charter.....      | Statesboro HS        |
| Tallulah Falls (Boarding) ..... | Habersham Central HS |
| Trinity Christian.....          | East Coweta HS       |
| Utopian Academy.....            | Morrow HS            |
| Walker School.....              | Marietta HS          |
| W.D. Mohammed.....              | McNair HS            |
| Weber School.....               | North Springs HS     |
| Wesleyan School.....            | Norcross HS          |
| Westminster.....                | North Atlanta HS     |
| Whitefield Academy.....         | Pebblebrook HS       |
| Woodward Academy.....           | Tri-Cities HS        |

# APPENDIX ‘S-R’

## STUDENT RECLASSIFICATION AREAS FOR NON-PUBLIC & CHARTER MEMBER SCHOOLS

(The Student Reclassification Area for non-public and charter member schools is a public school service area chosen by the non-public or charter school for reclassification purposes only. It must be in the county in which the school resides.)

| <b><u>SCHOOL</u></b> .....      | <b><u>RECLASS AREA</u></b> |
|---------------------------------|----------------------------|
| ACE Charter.....                | Howard HS                  |
| Aquinas.....                    | Richmond Academy           |
| Athens Academy.....             | Oconee County HS           |
| Athens Christian.....           | Cedar Shoals HS            |
| Atlanta Classical Charter.....  | North Atlanta HS           |
| Atlanta International.....      | North Atlanta HS           |
| Baconton Charter.....           | Mitchell County HS         |
| Ben Franklin (Boarding) .....   | Druid Hills HS             |
| Benedictine.....                | Jenkins HS                 |
| Blessed Trinity.....            | Roswell HS                 |
| Calvary Day School.....         | Jenkins HS                 |
| Christian Heritage.....         | Dalton HS                  |
| Darlington.....                 | Rome HS                    |
| Drew Charter.....               | Jackson-Atlanta HS         |
| ELCA.....                       | Union Grove HS             |
| Fellowship Christian.....       | Roswell HS                 |
| Fulton Leadership Charter.....  | Tri-Cities HS              |
| Furlow Charter.....             | Sumter County HS           |
| Galloway.....                   | Riverwood HS               |
| Genesis Innovative Academy..... | Douglass HS                |
| Georgia Fugees Academy.....     | Tucker HS                  |
| Greater Atlanta Christian ..... | Meadowcreek HS             |
| Greenforest Christian .....     | Columbia HS                |
| GSIC Charter.....               | Hephzibah HS               |
| Hapeville Charter.....          | Banneker HS                |
| Hebron Christian.....           | Dacula HS                  |
| Holy Innocents'.....            | Riverwood HS               |
| King’s Ridge Christian.....     | Cambridge HS               |
| KIPP Atlanta Charter.....       | Douglass HS                |
| Lake Oconee Academy.....        | Greene County HS           |
| Landmark Christian.....         | Creekside HS               |
| Lovett.....                     | North Atlanta HS           |
| Marist.....                     | Chamblee HS                |
| Mt. Bethel.....                 | Sprayberry HS              |
| Mt. Paran Christian.....        | Kennesaw Mountain HS       |
| Mt. Pisgah Christian.....       | Centennial HS              |

| <b><u>SCHOOL</u></b> .....    | <b><u>RECLASS AREA</u></b> |
|-------------------------------|----------------------------|
| Mt. Vernon School.....        | North Springs HS           |
| North Cobb Christian.....     | North Cobb HS              |
| NW Classical Ac. (2024-25)... | North Cobb HS              |
| Pace Academy.....             | North Atlanta HS           |
| Paideia.....                  | Druid Hills HS             |
| Pataula Charter.....          | Calhoun County HS          |
| Prince Avenue Christian ..... | North Oconee HS            |
| Providence Christian.....     | Berkmar HS                 |
| St. Francis.....              | Cambridge HS               |
| St. Pius X.....               | Cross Keys HS              |
| St. Vincent's Academy.....    | Savannah HS                |
| Savannah Christian.....       | Groves HS                  |
| Savannah Classical.....       | Savannah Arts Academy      |
| Savannah Country Day.....     | Windsor Forest HS          |
| SW Atlanta Christian.....     | Therrell HS                |
| SW Georgia STEM.....          | Randolph-Clay HS           |
| STEAM Academy Charter.....    | Statesboro HS              |
| Tallah Falls (Boarding) ..... | Habersham Central HS       |
| Trinity Christian.....        | East Coweta HS             |
| Utopian Academy.....          | Morrow HS                  |
| Walker School.....            | Marietta HS                |
| W.D. Mohammed.....            | McNair HS                  |
| Weber School.....             | North Springs HS           |
| Wesleyan School.....          | Norcross HS                |
| Westminster.....              | North Atlanta HS           |
| Whitefield Academy.....       | Pebblebrook HS             |
| Woodward Academy.....         | Tri-Cities HS              |

## **APPENDIX 'Z'**

# **Results & Records of State Playoff Events from 2022-23 School Year**

# STATE LITERARY - 2023

## A, Division I

### **Extemporaneous Speaking - Domestic**

1. Ryan Strickland, Armuchee
2. Ela Ash, Irwin County
3. Marli Jones, Bleckley County
4. Caroline Booher, Social Circle

### **Extemporaneous Speaking - International**

1. Charlie Brewer, Oglethorpe County
2. Emalee Collins, Armuchee
3. Nora Michaelis, King's Ridge
4. Aidan Willingham, Bleckley County

### **Literary Interpretation - Solo Humorous**

1. Kaylor Jones, Prince Avenue
2. Lauren Coley, Bleckley County
3. Jaclyn David, St. Francis
4. Noah Gray, Athens Christian

### **Literary Interpretation - Solo Dramatic**

1. Callie Paulk, Bleckley County
2. Malayla Malloy, Coosa
3. Sophia Chau, King's Ridge
4. Natalie Schroeder, Prince Avenue

### **Literary Interpretation - Duo**

1. Dade Co.: Jordyn Crane, Aiden Ross
2. King's Rdg: Nora Michaelis, Kate Lazewski
3. Bleckley: Allie Hathaway, Carter Willingham
4. Barrow: Drue Manco, Emily Gattis

### **Essay - Argumentative**

1. James Cairney, Bleckley County
2. Aracely Calderon, Dalton Academy
3. Minerva Logan, Commerce
3. Fatuyama Drammeh, Temple

### **Essay - Personal**

1. Lauren Coley, Bleckley County
2. Alexis Lemmings, Chattooga
3. Connie Tarpley, Temple
4. Jaiden Mobley, Irwin County

### **Essay - Literary Analysis**

1. Madeline Briscoe, Temple
2. Emma Grace Jarvis, Elbert County
3. Tanish Patel, Trion
4. Neveah McGuire, St. Francis

### **Boys Solo**

1. Josh Gilbert, Bleckley County
2. Braden Byram, Athens Christian
3. Logan Rawson, King's Ridge
4. Zachary Wright, Coosa

### **Girls Solo**

1. Claire Gann, Prince Avenue
2. Maddy Land, Bleckley County
3. Lily Gardiner, King's Ridge
4. Tannah Patton, Temple

### **Trio**

1. King's Rdg: Lily Gardiner, Roxanna Karim, Sammie Codrington
2. Pepperell: Gracie Hutcheson, Emily Martin, Ainsley Hilton
3. Bleckley Co.: Maddy Land, Lauren Coley, Allie Hathaway
4. Athens Christian: Hollis Williams, Annie Rollins, Ansley Moore

### **Quartet**

1. Bleckley Co.: Josh Gilbert, Zach Gilbert, Logan Davis, Will Green
2. Prince Avenue: Cooper Capps, Dylan Capps, Michael Moretti, Daniel Schroeder
3. King's Ridge: Logan Rawson, Garrett Bye, Ryder Thomason, Marques Muscott
4. Athens Chr.: Braden Byram, Zac Colquitt, Ethan Woodlief, Livingston Jenkins

### **Team Winners**

1. Bleckley County - 55
2. King's Ridge - 27
3. Prince Avenue - 20
4. Temple - 13

## A, Division II

### **Extemporaneous Speaking - Domestic**

1. Halsey Bosart, Lake Oconee Academy
2. Emma Kate Godin, GMC
3. Peyton McRae, Rainey-McCullers
4. Rahlyn Green, Christian Heritage

### **Extemporaneous Speaking - International**

1. Shriyansh Parekh, GMC
2. Abigail Hay, Miller County
3. Mora Redding, Echols County
4. Sara Sfakiankos, Rainey-McCullers

### **Literary Interpretation - Solo Humorous**

1. Cheyanne Dixon, GMC
2. Elisa Garcia-Carreras, Lake Oconee Acad.
3. Jada Williams, Rainey-McCullers
4. Gracia Wright, Christian Heritage

### **Literary Interpretation - Solo Dramatic**

1. Nikki Cumba, GMC
2. Cyra Kaikobad, Christian Heritage
3. Noelle Larkin, Rainey-McCullers
4. Leanne Pollock, Seminole County

### **Literary Interpretation - Duo**

1. GMC: Wyatt Baugh, Alexis Waldroup
2. Christian Her.: Cyra Kaikobad, Gracia Wright
3. Schley Co.: Doyle Peek, Mariana DeTitta,
4. Seminole Co.: Brian Sims, Kerionna Moore

### **Essay - Argumentative**

1. Abigail Hay, Miller County
2. William Steinfeld, GMC
3. Tegan Rigdon, Wheeler County
4. Maria Marquez, Lake Oconee Academy

### **Essay - Personal**

1. Shelby Pollock, Baconton
2. Tucker Ivey, GMC
3. Molly Bridges, Wheeler County
4. Caleb Morse, Mt. Zion-Carroll

### **Essay - Literary Analysis**

1. Maggi Gibson, Mt. Zion-Carroll
2. Helen Chow, GMC
3. Joseph Oliver, Early County
4. Zoey Adair, Atkinson County

### **Boys Solo**

1. Markus Cooper, Miller County
2. Nathan Simpson, GMC
3. Judson Graham, Charlton County
4. Paul Conner, Aquinas

### **Girls Solo**

1. Emerson Ivey, GMC
2. Emma Lester, Christian Heritage
3. Kamryn Jordan, Telfair County
4. Haley McLeod, Echols County

### **Trio**

1. GMC: Emerson Ivey, Abigail Johnson, Jacie Hartzog
2. Lake Oconee Acad.: Elisa Garcia-Carreras, Haley Heinen, Jewell Morrison
3. Charlton County: Trinity Bryant, Abby Crawford, Addie Jacoby
4. Seminole Co.: JoBeth Kelley, Hope Humphries, Kelsey Nunnery
4. Telfair Co.: Piper Gullion, Alhana Joiner, Kamryn Jordan

### **Quartet**

1. Charlton Co.: Caleb Bryant, Jonah Capps-Harris, Judson Graham, Tanner Murray
2. GMC: Wyatt Baugh, Maddox Raburn, Nathan Simpson, Kenyon Shy
3. Seminole Co.: Zaravion Calloway, Matt Burkett, Quinton Chavers, Pearson Fields
4. Telfair County: Daraishawn Bryant, Wes Pope, Hall White, Christon Zanders

### **Team Winners**

1. Georgia Military College - 72
2. Miller County - 19
3. Lake Oconee Academy - 18
4. Christian Heritage - 17

## 2A

### **Extemporaneous Speaking - Domestic**

1. Abigail Cornelius, East Jackson
2. Emonie McReynolds, Gordon Central
3. Phillip Cox, ACE Charter
4. Rafael Geraldo, Johnson-Augusta

### **Extemporaneous Speaking - International**

1. Sara Grace Abernathy, Model
2. MKayli Roberson, Washington County
3. Evan Jordan, ACE Charter
4. Keely Shipe, Pierce County

### **Literary Interpretation - Solo Humorous**

1. Laila Johnson, Fitzgerald
1. Alan Johnson, Vidalia
3. Emileigh Ashworth, Model
4. Trinity Williams, East Jackson

### **Literary Interpretation - Solo Dramatic**

1. Melissa Colombo, ACE Charter
2. Sage Powell, Vidalia
3. Siena Avolio, Athens Academy
4. Eva Petty, Model

### **Literary Interpretation - Duo**

1. Vidalia: Dottie McDaniel, Alan Johnson
2. ACE Charter: Zachia Wilkerson, Jack Strandberg
3. Putnam Co.: Emma Jo Parham, David Trice
4. East Jackson: Rosie Camp, Juliet Camp

### **Essay - Argumentative**

1. Camille Fry, ACE Charter
2. Cianna Kicklighter, Pierce County
3. Lucy Hayes, Athens Academy
4. Blair Littlefield, Callaway

### **Essay - Personal**

1. Sara Grace Abernathy, Model
2. Courtney Black, Brantley County
3. Rachel Simmons, East Jackson
4. Chandler Paulk, Dodge County

### **Essay - Literary Analysis**

1. Barrett Nardi, Dodge County
2. Sharif Taylor Jr., Johnson-Augusta
3. Sarah Harrison, Athens Academy
4. Annabelle Lee, Model

### **Boys Solo**

1. Landon Clark, North Cobb Christian
2. Justin Herrin, Pierce County
2. Tyrese Riddle, Washington County
4. Dalton Fletcher, Rockmart

### **Girls Solo**

1. Kayleigh Brock, ACE Charter
2. Caitlyn Lindstrom, Fannin County
3. Shannon Collins, Vidalia
4. Delaney Corley, Washington County

### **Trio**

1. Washington County: Claire Buck, Delaney Corley, Tori Beth Sheram
2. ACE Charter: Melody Tyner, Alexia Levrette, Kayleigh Brock
3. Vidalia: Lily Rowe, D. J. Edwards, Mary Tomberlin
4. Gordon Central: Catherine Hughes, Sadie Holmes, Aliyah Mills

### **Quartet**

1. Gordon Central: Tyler Waits, Jude Clance, Bobby Hicks, Seth Kolterman
2. Washington County: Nicholas Duckworth, Alex Tu, Brian Warthen, Tyrese Riddle
3. Vidalia: Micah Davis-Brown, Cole Dean, Andrew Davis, Landry Wheeler
4. East Jackson: Isaac Miller, Shane McAlister, Liam Searan, Trace Griffin

### **Team Winners**

1. ACE Charter - 37
2. Vidalia - 27
3. Washington County - 22
4. Model - 19



# STATE LITERARY - 2023

## 3A

### Extemporaneous Speaking - Domestic

1. Michael Marola, Columbus
2. Aaron Knapp, Oconee County
3. Ella Baker, Adairsville
4. Daisy Clay, Liberty County

### Extemporaneous Speaking - International

1. Yujean Shin, Bremen
2. Faith Tucker, Oconee County
3. Eleanor Moss, Morgan County
4. Aima Sharma, Columbus

### Literary Interpretation - Solo Humorous

1. Rory Powers, Bremen
2. Dylan Henschen, Lumpkin County
3. Jackson Tucker, Oconee County
4. Ava Nelson, Mary Persons

### Literary Interpretation - Solo Dramatic

1. Brock Bullock, Bremen
2. Lane Anderson, Lumpkin County
3. Lucy Thompson, Savannah Christian
4. Aubree McLendon, Pike County

### Literary Interpretation - Duo

1. Oconee County: Abel Clark, Aaron Knapp
2. Ringgold: Taylor Rice, Amy Skrgic
3. Pike Co.: Aubree McLendon, Kaite Hedden
3. Lumpkin Co.: Collin Edwardson, Joshua Miklas

### Essay - Argumentative

1. Annie McCormick, Adairsville
2. Tanay Pathakamuri, Columbus
3. Makenzie Edge, Pike County
4. Andrea Bailey, Morgan County

### Essay - Personal

1. Faith Linius, Sandy Creek
2. Claudia Lancheros, Bremen
3. Maggie Dowdy, Dawson County
4. Grace Johnson, Columbus

### Essay - Literary Analysis

1. Lily Gambrell, Bremen
2. Morgan Bryant, Sandy Creek
3. Jimmy Kelley, Savannah Christian
4. Anika Sidhar, Columbus

### Boys Solo

1. Charles McGregor, Morgan County
2. William Little, Mary Persons
3. Carson Tomlinson, Columbus
4. Jackson Tucker, Oconee County

### Girls Solo

1. Mekayla Daniel, Columbus
2. Sydney Stapleton, Mary Persons
3. Danielle Lusian, Adairsville
4. Nora Feeney, Lumpkin County

### Trio

1. Bremen: Ava Smith, Hope Cohran, Sara Nicholson
2. Columbus: Makayla Daniel, Tiffany Le, Bella Valentine
3. Sandy Creek: Nahri Marks, Kellsey Miller, Heaven Webb
4. Morgan County: Sora Rose, Emily Highfill, Grace Fowler

### Quartet

1. Lumpkin County: Jackson McKinney, Michael Young, Dylan Henschen, William McKinney
2. Ringgold: Luke Garverick, Chance Prichard, Brayden Roach, Trevor Arnold
3. Oconee County: JW Hale, Jaxson Rufner, Jimmy Mullinax, Aaron Knapp
4. Mary Persons: Luke McBride, Jackson Roller, William Little, Riley Von Voorhis

### Team Winners

1. Bremen - 40
2. Columbus - 30
3. Oconee County - 24
4. Lumpkin County - 20

## 4A

### Extemporaneous Speaking - Domestic

1. Robinson York, Baldwin
2. Laila Carter, North Oconee
3. Seth Wright, Cedartown
4. Erica Middleton, Wayne County

### Extemporaneous Speaking - International

1. Natalie Ferry, Heritage-Catoosa
2. Lillian Harper, Howard
3. Parker Abbott, Chestatee
4. Jace Cooksey, Wayne County

### Literary Interpretation - Solo Humorous

1. Riley Tucker, Chestatee
2. Nathaly Rangel-Gonzalez, Fayette County
3. Kelsie Morath, Perry
3. Ambree Quarles, Sonoraville

### Literary Interpretation - Solo Dramatic

1. Laineey Lyle, North Oconee
2. Chrissy Garvin, NW Whitfield
3. Matthew Little, Starr's Mill
4. Britten Wood, Perry

### Literary Interpretation - Duo

1. N. Oconee: John Max Patrick, Lydia Peck
2. Perry: Christian Kemp, Janie Martin
3. NW Whit.: Henley Green, Ryeder Underwood
4. LaGrange: Danielle Kemper, Beth McGowen

### Essay - Argumentative

1. Xuan Yang, Baldwin
2. Tyler Abercrombie, Sonoraville
3. Ella Griswold, Starr's Mill
4. Zimil Jamsa, Wayne County

### Essay - Personal

1. Peyton Alex Hatcher, Bainbridge
2. Yan Yang, Baldwin
3. Moriah Kelly, Wayne County
4. Faith Johnson, Whitewater

### Essay - Literary Analysis

1. Lawson Smith, North Hall
2. Kimber Braren, Cedartown
3. Elaine Abella, Baldwin
4. Cadence Davis, Troup

### Boys Solo

1. Micah Kilgore, North Oconee
2. Logan Robinson, Central-Carroll
3. Evan Wyatt, West Laurens
4. Ryan Whitaker, SE Bulloch
4. Julian Agudelo, Starr's Mill

### Girls Solo

1. Carly Cannon, Pace Academy
2. Sara Maghlar, SE Bulloch
3. Laila Carter, North Oconee
4. Olivia Vande Kerkoff, Central-Carroll

### Trio

1. Heritage-Catoosa: Avery Frost, Camryn McCormick, Caleb Jackson
1. Seckinger: Eun Kang, Phoebe Yoon, Kaylee Oh
3. SE Bulloch: Fiona Earl, Olivia Horton, Chazz Schumann
4. Cairo: Nylyvia Corker, Kyla Pierce, Kennedy Smart

### Quartet

1. Chestatee: Kaden Childs, John Sykes, Molefe Sijiyi, Mitchell Ryder
2. SE Bulloch: Ryan Whitaker, Ian Talkington, Hunter Thompson, Nick Gapac
3. Central-Carr.: Reagan Latham, Logan Robinson, Harrisom Prince, Caidence Brown
4. Westover: Jarell Reliford, Tyler Leanza, Malachi Wright, Oziyah Robinson

### Team Winners

1. North Oconee - 29
2. Baldwin - 22
3. Chestatee - 17
4. Southeast Bulloch - 13.5

## 5A

### Extemporaneous Speaking - Domestic

1. Abigail Foreman, Jefferson
2. Sarah Forberger, Dalton
2. Gray Hamby, Decatur
4. Callie Wilson, Warner Robins

### Extemporaneous Speaking - International

1. Gabrielle Riley, Greenbrier
2. Nikita Takalakar, Decatur
3. Nate Eickman, Calhoun
4. Tristin Scarbrough, Ola
4. Abigail Grace Ricker, Northside-Col.

### Literary Interpretation - Solo Humorous

1. Travis Lucas, Warner Robins
2. Rebekah Mason, GACS
3. Catherine Covinton, Calhoun
4. Derek Varney, Greenbrier

### Literary Interpretation - Solo Dramatic

1. Caroline Castle, Flowery Branch
1. Amiyah Elam, Ware County
3. Tira Cousins, Calhoun
4. Lizzie Merritt, Jones County

### Literary Interpretation - Duo

1. War. Robins: Travis Lucas, Ashton Harden
1. Calhoun: Chloe McFarlad, Addi Lester
3. N'side-Col.: Nadia Chestnut, Ariana Britton
4. Coffee: Xymesha Walker, Jocelyn Lott

### Essay - Argumentative

1. Emma Denton, GACS
2. Jessie Rogers, Loganville
3. Libby Hartley, Villa Rica
4. William Hutcheson, Coffee

### Essay - Personal

1. Alex Taylor, Union Grove
2. Carina Solis, Villa Rica
3. Paul Hayman, Cartersville
4. Mia Carlton, GACS

### Essay - Literary Analysis

1. Landon Teal, Northside-Columbus
2. Joseph Burke, Decatur
3. Sophia Nguyen, GACS
4. Eli Burt, Dalton

### Boys Solo

1. Makoa Whitefield, Warner Robins
2. Jonathan Stonehocker, Greenbrier
3. Sam Bernstein, Cartersville
4. Zachary Hornbeck, Northgate

### Girls Solo

1. Isabella Bradshaw, Villa Rica
1. Sydney Barbour, GACS
3. Hannah Willoughby, Woodland-Bartow
4. Bethany Tapee, Jones County

### Trio

1. Calhoun: Anna Kathryn Hayes, Mayce Holland, Graycen Nudd
2. Jones County: Paige Pieterick, Bethany Tapee, Leah Ward
3. Heritage-Conyers: Imani Edwards, Mya Moore, Aniyah Ross
4. GACS: Malia Campos, Lorelei Osborne, Laila Washington

### Quartet

1. Ware County: Caleb Ker, Jose Lopez, Josh Musgrove, Shaton Stewart
2. Heritage-Conyers: Cameron Usher, Korbin Parker, Prince Richards, Greg Alderson
3. Calhoun: Adrian Galylean, Porter Ledford, Caleb Riley, Brandon Webb
3. GACS: Aiden Daniels, Jayden Holland, Guanhan Liu, Thomas Hawkes

### Team Winners

1. Greater Atlanta Christian - 25
2. Calhoun - 24
3. Warner Robins - 21
4. Decatur - 14
4. Villa Rica - 14

# STATE LITERARY - 2023

## 6A

### Extemporaneous Speaking - Domestic

1. Ellie Kirkland, Houston County
2. Taryn Mareau, Sequoyah
3. Emily Soares, Grovetown
4. Brittany Brown, Douglas County

### Extemporaneous Speaking - International

1. Margaret Haggerty, Sequoyah
2. Nicholas Meyer, Roswell
3. Nolan Bell, Jackson County
4. MaCayla Moody, Northside-W. Robins

### Literary Interpretation - Solo Humorous

1. Walker Durham, Northside-W. Robins
1. Jack Shaffer, Lakeside-Evans
3. Brayden Bayle, Alexander
4. Kristopher Jacob, Apalachee
4. Abby McWethy, Woodstock

### Literary Interpretation - Solo Dramatic

1. Bryson Carter, Northside-W. Robins
2. Madison Streeter, Apalachee
3. Hannah Veale, Roswell
4. Lydia Lord, Woodstock

### Literary Interpretation - Duo

1. Glynn Acad.: Austin Lofquist, Lily Tilgham
2. Houston Co.: Logan Adams, Bryce Warren
3. St. Pius: Avery Jones, Kinsley Kler
3. Sequoyah: Dakota Youngblood, Emma Jira

### Essay - Argumentative

1. Jackson Griffith, Houston County
2. William Nicholson, Roswell
3. Ryan Murray, Alexander
4. Alyssa Woo, Gainesville

### Essay - Personal

1. Libbie Brownlow, St. Pius
2. James Kasten, East Paulding
3. Stella Turner, Rome
4. Anne Hensley Young, Lakeside-Evans

### Essay - Literary Analysis

1. Charlotte Hunter, Douglas County
2. Amelia Gerdes, St. Pius
3. Sophia Aziz, Alpharetta
4. Christina Tillis, Lee County

### Boys Solo

1. JR Banitt, North Forsyth
2. Aidan Eclavea, Lakeside-Evans
3. Connor McCarthy, St. Pius
4. Bryson Carter, Northside-W. Robins

### Girls Solo

1. Teagan Durham, Sequoyah
2. Morgan Mann, East Paulding
3. Abigail Bragg, Houston County

4. Hannah Winn, Lakeside-Evans

### Trio

1. North Forsyth: Anniston Boyanton, Natalie Hamm, Anna Grace Martin
2. Houston County: Abigail Bragg, Catherine Nix, Addie Page Munn
3. Sequoyah: Leah Brown, Emma Jira, Taryn Mareau
4. St. Pius: Omeno Abutu, Lauren Smith, Chloe Burgoon

### Quartet

1. North Forsyth: Noah Colwell, Adam Norton, JR Banitt, Ethan Thompson
2. Lakeside, Evans: Aidan Eclavea, Jack Shaffer, August Bauer, James Williams
3. Lee County: Isaiah Williams, Ian Harding, Jayden Evans, Cameron Jernigan
4. Creekview: Logan Nalley, Trey Stannard, Connor Vitak, Kota Freeborn

### Team Winners

1. Houston County - 27
2. Sequoyah - 24
3. North Forsyth - 21
4. Lakeside-Evans - 18
4. St. Pius - 18

## 7A

### Extemporaneous Speaking - Domestic

1. Joanna Xiao, Richmond Hill
2. Emmanuela Ejoga, North Cobb
3. Addison Denny, Forsyth Central
4. Mark Zimmer, Carrollton

### Extemporaneous Speaking - International

1. Kieran Kelly, Carrollton
2. Anderson McKnight, Forsyth Central
3. Matthew Adkins, Richmond Hill
4. Etinosa Ogbomo, Marietta

### Literary Interpretation - Solo Humorous

1. Emily Marx, Denmark
2. Adrian Lindsay, Kennesaw Mountain
3. Christopher Rischar, Buford
4. Cody Reed, Carrollton

### Literary Interpretation - Solo Dramatic

1. Daniel Evans, Denmark
2. Dyllan Glaze, Harrison
3. Emmanuel Mwangi, Cherokee
4. Grace Johnson, Buford

### Literary Interpretation - Duo

1. Cherokee: Lily Richard, Wyatt Darnell
2. Buford: Jack Hall, Christopher Rischar
2. South Forsyth: Julia Mallard, Nick Myers
4. Harrison: Kendall Brisco, Emma Kate Noggle

### Essay - Argumentative

1. Lily Hurn, Hillgrove
2. Natalie Knight, Forsyth Central
3. Indrakumar Sutharsan, Parkview
4. Kieran Kelly, Carrollton

### Essay - Personal

1. Anna Williams, Buford
2. Rachel Tew, Cherokee
3. Poojah Darayatna, Lowndes
4. Brendan Turner, South Forsyth

### Essay - Literary Analysis

1. Nate Augustin, Mill Creek
2. Rhiannon Crisante, Cherokee
3. Andrew Johnson, Carrollton
4. Chance Fewell, Discovery

### Boys Solo

1. Roger Wang, Lambert
2. Isaiah Nelson, Mill Creek
3. Simri Martinez, North Cobb
4. Sunoo Kim, Richmond Hill

### Girls Solo

1. Elizabeth Guy, Denmark
2. Mara Eva Cline, Buford
3. Margaret Black, Marietta
4. Skylar Hundley, Carrollton

### Trio

1. Buford: Maggie Dale, Mara Eva Cline, Mariana Borja
1. Denmark: Thea Valencia, Elizabeth Guy, Isabella Barbarena
3. Harrison: Sophia Caveney, Erin Young, Lauren Sweat
4. Kennesaw Mountain: Camille Simmonds, Mamajan Diallo, Alfia Amoako Boteng

### Quartet

1. Denmark: Andrew Pijanowski, Colin Paisley, Gavin Bass, Jackson Green
2. Kennesaw Mountain: Juan Hernandez, William Tyler, Nathan McKee, Ben Trussell
3. Colquitt County: Wade Swartzentruber, Jesus Sanchez Trejo, Ryan Tuff, Jonah Hagin
3. Buford: Luke Riza, Jack Hall, Trevor Puckett, Samuel Son

### Team Winners

1. Denmark - 34
2. Buford - 28
3. Cherokee - 20
4. Carrollton - 14

# STATE ONE-ACT PLAY - 2022-23

## 7A

1. Lambert – “Tuck Everlasting”
2. Cherokee – “Charlie’s Aunt”
3. Duluth – “Our Place”
4. Central Gwinnett – “Side Show”

**Best Actress:** Madeline Hanson – Lambert

**Best Actor:** Wyatt Darnell – Cherokee

□

## 6A

1. Allatoona – “Wiley and The Hairy Man”
2. Lakeside, DeKalb – “The Romancers”
3. Northside, Warner Robins – “The 25th Annual Putnam County Spelling Bee”
4. Alpharetta – “Mother Hicks”

**Best Actress:** Jada Thompson – Allatoona

**Best Actor:** Cayden Phillips – Allatoona

## 5A

1. Calhoun – “Bright Star”
2. Midtown – “Our Place”
3. Warner Robins – “Newsies”
4. Greenbrier – “Sistas”

**Best Actress:** Anna Kathryn Hayes – Calhoun

**Best Actor:** Travis Lucas – Warner Robins

## 4A

1. North Oconee – “Hetty Feather”
2. Troup – “Storm in the Barn”
3. Northwest Whitfield – “Romeo and Juliet”
4. Perry – “Still Life with Iris”

**Best Actress:** Lainey Lyle – North Oconee

**Best Actor:** Ryder Underwood – NW Whitfield

## 3A

1. Ringgold – “Mary Poppins”
2. Franklin County – “Sweeney Todd”
3. Columbus – “Our Place”
4. Sav. Country Day – “Scenes from Diviners”

**Best Actress:** Cassidy McCormick – Ringgold

**Best Actor:** Jon Erik Tripp – Franklin County

## 2A

1. Academy of Classical Education – “Doors”
2. Haralson County – “Twelve Angry Jurors”
3. South Atlanta – “Antigone Now”

4. Pierce County – “Silent Sky”

**Best Actress:** Zachia Wilkerson – ACE Charter

**Best Actor:** Ronnie McCoy – South Atlanta

## A, Division 1

1. Bleckley County – “9 to 5”
  2. Prince Avenue Christian – “Crazy for You”
  3. Armuchee – “Interrupting Vanessa”
  4. Crawford County – “Getting Near to Baby”
- Best Actress:** Lauren Coley – Bleckley County
- Best Actor:** Dylan Capps – Prince Avenue

## A, Division 2

1. Georgia Military College – “All Shook Up”
  2. Lake Oconee Academy – “Mockingbird”
  3. Rainey McCullers School of the Arts – “9 to 5”
  4. Echols County – “Around the World in 80 Days”
- Best Actress:** Elisa Garcia-Carreras – Lake Oconee Academy
- Best Actor:** Ryland Britt – GMC

# STATE BASEBALL PLAYOFFS - 2023

## Class 7A

### Round 1

|                   |           |                 |          |
|-------------------|-----------|-----------------|----------|
| Forsyth Central   | 9, 7      | Cherokee        | 8, 0     |
| North Gwinnett    | 13, 10    | Mountain View   | 0, 0     |
| Grayson           | 11, 1, 6  | Marietta        | 2, 5, 5  |
| Lowndes           | 15, 12    | Westlake        | 11, 2    |
| Walton            | 3, 2, 4   | South Forsyth   | 2, 6, 0  |
| Buford            | 10, 3, 10 | Peachtree Ridge | 0, 8, 1  |
| North Paulding    | 15, 6     | Brookwood       | 14, 1    |
| East Coweta       | 9, 12     | Colquitt County | 4, 1     |
| Carrollton        | 7, 7      | Valdosta        | 4, 6     |
| Hillgrove         | 7, 5      | Archer          | 2, 0     |
| Mill Creek        | 12, 8     | Duluth          | 2, 1     |
| Kennesaw Mountain | 7, 9, 7   | Lambert         | 14, 7, 2 |
| Richmond Hill     | 6, 3      | Campbell        | 5, 0     |
| Parkview          | 7, 9      | McEachern       | 2, 3     |
| Dacula            | 4, 6      | Norcross        | 2, 3     |
| Denmark           | 14, 15    | North Cobb      | 4, 4     |

### Round 2

|                |          |                   |          |
|----------------|----------|-------------------|----------|
| North Gwinnett | 17, 7, 5 | Forsyth Central   | 10, 8, 0 |
| Lowndes        | 8, 16    | Grayson           | 6, 1     |
| Walton         | 4, 8     | Buford            | 2, 3     |
| North Paulding | 0, 2, 7  | East Coweta       | 7, 1, 4  |
| Hillgrove      | 11, 1    | Carrollton        | 1, 0     |
| Mill Creek     | 8, 10    | Kennesaw Mountain | 6, 0     |
| Parkview       | 11, 13   | Richmond Hill     | 1, 1     |
| Dacula         | 4, 2, 10 | Denmark           | 1, 9, 0  |

### Quarterfinals

|                |         |                |          |
|----------------|---------|----------------|----------|
| Lowndes        | 3, 9, 9 | North Gwinnett | 12, 4, 3 |
| North Paulding | 4, 2    | Walton         | 2, 1     |
| Mill Creek     | 4, 1, 7 | Hillgrove      | 1, 2, 1  |
| Parkview       | 4, 1, 8 | Dacula         | 2, 3, 7  |

### Semifinals

|          |        |                |      |
|----------|--------|----------------|------|
| Lowndes  | 3, 4   | North Paulding | 0, 3 |
| Parkview | 10, 12 | Mill Creek     | 0, 2 |

### Final

|         |      |          |      |
|---------|------|----------|------|
| Lowndes | 3, 5 | Parkview | 2, 2 |
|---------|------|----------|------|

## Class 6A

### Round 1

|                       |           |                 |         |
|-----------------------|-----------|-----------------|---------|
| Allatoona             | 3, 10     | East Paulding   | 0, 2    |
| Blessed Trinity       | 10, 6     | Jackson County  | 4, 2    |
| Marist                | 6, 11     | Alcovy          | 0, 0    |
| Houston County        | 13, 11    | Brunswick       | 1, 4    |
| Etowah                | 12, 10    | Newnan          | 3, 1    |
| North Forsyth         | 2, 4      | Roswell         | 0, 2    |
| St. Pius X            | 7, 15     | Forest Park     | 0, 0    |
| Thomas County Central | 7, 4      | Evans           | 5, 2    |
| Glynn Academy         | 4, 10     | Lee County      | 0, 4    |
| Woodward Academy      | 3, 14     | Dunwoody        | 1, 3    |
| Lassiter              | 6, 13, 11 | Lanier          | 9, 3, 9 |
| River Ridge           | 4, 10     | Alexander       | 1, 0    |
| Tift County           | 7, 2      | South Effingham | 2, 1    |
| North Atlanta         | 15, 6     | Jonesboro       | 0, 1    |
| Pope                  | 4, 18, 12 | Apalachee       | 6, 2, 2 |
| Woodstock             | 15, 5     | South Paulding  | 3, 1    |

### Round 2

|                       |          |               |          |
|-----------------------|----------|---------------|----------|
| Blessed Trinity       | 3, 10    | Allatoona     | 2, 0     |
| Houston County        | 8, 3, 17 | Marist        | 3, 7, 7  |
| Etowah                | 14, 7    | North Forsyth | 0, 3     |
| Thomas County Central | 4, 0, 11 | St. Pius X    | 2, 12, 4 |
| Woodward Academy      | 8, 6     | Glynn Academy | 7, 2     |
| River Ridge           | 3, 4     | Lassiter      | 0, 3     |
| Tift County           | 5, 4, 16 | North Atlanta | 6, 0, 4  |
| Pope                  | 1, 3, 5  | Woodstock     | 3, 2, 2  |

### Quarterfinals

|                |         |                       |          |
|----------------|---------|-----------------------|----------|
| Houston County | 3, 4, 6 | Blessed Trinity       | 5, 2, 1  |
| Etowah         | 7, 3    | Thomas County Central | 2, 1     |
| River Ridge    | 4, 7, 9 | Woodward Academy      | 13, 0, 4 |
| Pope           | 10, 5   | Tift County           | 2, 1     |

### Semifinals

|                |        |             |      |
|----------------|--------|-------------|------|
| Houston County | 6, 4   | Etowah      | 5, 1 |
| Pope           | 10, 15 | River Ridge | 4, 3 |

### Final

|                |      |      |      |
|----------------|------|------|------|
| Houston County | 8, 7 | Pope | 3, 4 |
|----------------|------|------|------|

## Class 5A

### Round 1

|                    |         |                 |         |
|--------------------|---------|-----------------|---------|
| Cambridge          | 7, 18   | Jackson-Atlanta | 4, 1    |
| Cartersville       | 11, 2   | Jefferson       | 0, 0    |
| Northside-Columbus | 5, 8    | Chamblee        | 4, 3    |
| Greenbrier         | 1, 6    | Jones County    | 0, 4    |
| Chapel Hill        | 3, 4, 6 | GACS            | 8, 2, 4 |
| Loganville         | 11, 11  | Dalton          | 1, 4    |

|                |           |                 |          |
|----------------|-----------|-----------------|----------|
| Harris County  | 3, 7      | Tucker          | 2, 5     |
| Locust Grove   | 6, 7      | Statesboro      | 0, 0     |
| Ola            | 6, 11     | Ware County     | 3, 1     |
| McIntosh       | 19, 20    | Arabia Mountain | 0, 0     |
| Winder-Barrow  | 7, 3      | Calhoun         | 4, 0     |
| Villa Rica     | 4, 11, 8  | Kell            | 5, 5, 6  |
| Union Grove    | 2, 13     | Coffee          | 1, 9     |
| Decatur        | 11, 5, 11 | Northgate       | 1, 7, 0  |
| Flowery Branch | 1, 7, 7   | Woodland-Bartow | 0, 14, 0 |
| Centennial     | 10, 15    | Tri-Cities      | 0, 0     |

### Round 2

|               |          |                    |         |
|---------------|----------|--------------------|---------|
| Cartersville  | 5, 4     | Cambridge          | 1, 1    |
| Greenbrier    | 2, 9, 15 | Northside-Columbus | 9, 2, 5 |
| Loganville    | 5, 12    | Chapel Hill        | 1, 0    |
| Locust Grove  | 9, 5     | Harris County      | 5, 1    |
| McIntosh      | 2, 6     | Ola                | 1, 3    |
| Winder-Barrow | 3, 3     | Villa Rica         | 2, 2    |
| Decatur       | 20, 13   | Union Grove        | 10, 7   |
| Centennial    | 8, 4     | Flowery Branch     | 2, 3    |

### Quarterfinals

|            |          |               |         |
|------------|----------|---------------|---------|
| Greenbrier | 3, 6, 5  | Cartersville  | 4, 4, 3 |
| Loganville | 3, 5, 3  | Locust Grove  | 6, 0, 2 |
| McIntosh   | 10, 0, 5 | Winder-Barrow | 3, 3, 2 |
| Centennial | 5, 10    | Decatur       | 4, 4    |

### Semifinals

|            |          |            |          |
|------------|----------|------------|----------|
| Loganville | 12, 7    | Greenbrier | 5, 4     |
| McIntosh   | 0, 15, 9 | Centennial | 13, 9, 3 |

### Final

|            |      |          |      |
|------------|------|----------|------|
| Loganville | 4, 5 | McIntosh | 1, 4 |
|------------|------|----------|------|

## Class 4A

### Round 1

|                 |           |                   |         |
|-----------------|-----------|-------------------|---------|
| Westminster     | 11, 4     | Stockbridge       | 2, 3    |
| Cedartown       | 3, 13     | North Hall        | 0, 7    |
| Starr's Mill    | 3, 10     | Islands           | 1, 2    |
| Bainbridge      | 16, 17    | Baldwin           | 1, 3    |
| Pace Academy    | 7, 11     | Druid Hills       | 5, 2    |
| North Oconee    | 13, 12    | Central-Carroll   | 2, 0    |
| Whitewater      | 7, 2, 11  | Benedictine       | 5, 4, 4 |
| West Laurens    | 5, 22     | Westover          | 2, 2    |
| Perry           | 6, 7      | Cairo             | 2, 1    |
| Wayne County    | 11, 3, 16 | Trinity Christian | 1, 8, 1 |
| Cherokee Bluff  | 12, 9     | Heritage-Catoosa  | 2, 0    |
| Lovett          | 8, 12     | SW DeKalb         | 0, 0    |
| Shaw            | 3, 12     | Spalding          | 1, 2    |
| LaGrange        | 10, 14    | Burke County      | 2, 1    |
| East Forsyth    | 3, 11     | Sonoraville       | 0, 0    |
| Holy Innocents' | 7, 14     | Hampton           | 4, 0    |

### Round 2

|              |          |                 |           |
|--------------|----------|-----------------|-----------|
| Westminster  | 11, 6    | Cedartown       | 2, 2      |
| Starr's Mill | 9, 7     | Bainbridge      | 2, 3      |
| North Oconee | 14, 11   | Pace Academy    | 3, 7      |
| Whitewater   | 2, 6, 17 | West Laurens    | 10, 2, 10 |
| Wayne County | 4, 9, 12 | Perry           | 5, 2, 2   |
| Lovett       | 16, 6, 6 | Cherokee Bluff  | 6, 7, 5   |
| LaGrange     | 11, 13   | Shaw            | 5, 1      |
| East Forsyth | 7, 6, 8  | Holy Innocents' | 10, 3, 6  |

### Quarterfinals

|              |         |              |         |
|--------------|---------|--------------|---------|
| Starr's Mill | 11, 6   | Westminster  | 1, 0    |
| North Oconee | 14, 9   | Whitewater   | 5, 3    |
| Lovett       | 2, 9, 7 | Wayne County | 3, 2, 3 |
| LaGrange     | 3, 9    | East Forsyth | 2, 1    |

### Semifinals

|              |       |              |      |
|--------------|-------|--------------|------|
| North Oconee | 15, 4 | Starr's Mill | 5, 1 |
| LaGrange     | 4, 3  | Lovett       | 3, 2 |

### Final

|              |          |          |         |
|--------------|----------|----------|---------|
| North Oconee | 11, 5, 4 | LaGrange | 1, 6, 1 |
|--------------|----------|----------|---------|

## Class 3A

### Round 1

|                         |          |                      |         |
|-------------------------|----------|----------------------|---------|
| Gordon Lee              | 15, 15   | Cedar Grove          | 0, 0    |
| Pickens                 | 3, 5, 8  | Hart County          | 4, 4, 0 |
| Harlem                  | 10, 11   | Long County          | 4, 1    |
| Thomasville             | 13, 2, 1 | Peach County         | 6, 3, 0 |
| Adairsville             | 17, 15   | Carver-Atlanta       | 1, 0    |
| Franklin County         | 2, 0, 8  | Dawson County        | 1, 4, 1 |
| Calvary Day             | 10, 19   | Richmond Academy     | 2, 3    |
| Pike County             | 12, 18   | Dougherty            | 3, 1    |
| Mary Persons            | 5, 5, 11 | Crisp County         | 2, 6, 2 |
| Savannah Christian      | 15, 13   | Cross Creek          | 0, 0    |
| Oconee County           | 8, 10    | Lumpkin County       | 7, 3    |
| Lakeview-Ft. Oglethorpe | 13, 20   | Sandy Creek          | 2, 7    |
| Columbus                | 4, 8     | Upson-Lee            | 0, 0    |
| Morgan County           | 6, 17    | Savannah Country Day | 2, 2    |

# STATE BASEBALL PLAYOFFS - 2023

|                |        |                        |      |
|----------------|--------|------------------------|------|
| Wesleyan ..... | 8, 3   | Hebron Christian ..... | 7, 0 |
| Ringgold ..... | 16, 20 | Douglass-Atlanta ..... | 0, 0 |

### Round 2

|                          |          |                               |         |
|--------------------------|----------|-------------------------------|---------|
| Gordon Lee .....         | 4, 4, 3  | Pickens .....                 | 1, 5, 0 |
| Harlem .....             | 5, 11    | Thomasville .....             | 1, 1    |
| Franklin County .....    | 10, 12   | Adairsville .....             | 0, 8    |
| Pike County .....        | 10, 4    | Calvary Day .....             | 3, 1    |
| Savannah Christian ..... | 5, 8     | Mary Persons .....            | 4, 1    |
| Oconee County .....      | 3, 5, 16 | Lakeview-Ft. Oglethorpe ..... | 2, 6, 6 |
| Columbus .....           | 1, 4, 6  | Morgan County .....           | 4, 1, 4 |
| Ringgold .....           | 5, 8, 7  | Wesleyan .....                | 8, 1, 1 |

### Quarterfinals

|                          |          |                       |         |
|--------------------------|----------|-----------------------|---------|
| Harlem .....             | 2, 7     | Gordon Lee .....      | 1, 4    |
| Pike County .....        | 3, 3     | Franklin County ..... | 1, 0    |
| Savannah Christian ..... | 3, 8, 10 | Oconee County .....   | 5, 1, 8 |
| Ringgold .....           | 6, 2, 7  | Columbus .....        | 0, 4, 5 |

### Semifinals

|                |      |                          |      |
|----------------|------|--------------------------|------|
| Harlem .....   | 7, 3 | Pike County .....        | 5, 2 |
| Ringgold ..... | 1, 4 | Savannah Christian ..... | 0, 3 |

### Final

|              |      |                |      |
|--------------|------|----------------|------|
| Harlem ..... | 5, 2 | Ringgold ..... | 3, 1 |
|--------------|------|----------------|------|

### Class 2A

#### Round 1

|                            |           |                          |         |
|----------------------------|-----------|--------------------------|---------|
| Mt. Paran .....            | 10, 14    | ELCA .....               | 0, 2    |
| Model .....                | 10, 3, 13 | Athens Academy .....     | 0, 5, 2 |
| Toombs County .....        | 9, 0, 12  | Westside-Augusta .....   | 0, 3, 2 |
| Jeff Davis .....           | 15, 15    | Southwest .....          | 0, 0    |
| Walker .....               | 2, 5, 14  | Landmark Christian ..... | 3, 4, 4 |
| Fellowship Christian ..... | 5, 2      | Fannin County .....      | 2, 0    |
| Brantley County .....      | 9, 8      | Putnam County .....      | 4, 2    |
| Fitzgerald .....           | 7, 4      | ACE Charter .....        | 4, 3    |
| Worth County .....         | 14, 8     | Rutland .....            | 1, 1    |
| Appling County .....       | 11, 12    | Washington County .....  | 7, 1    |
| Rockmart .....             | 4, 3      | Banks County .....       | 3, 1    |
| Redan .....                | 9, 13     | Drew Charter .....       | 2, 0    |
| Cook .....                 | 11, 14    | Jordan .....             | 1, 2    |
| Vidalia .....              | 12, 4     | Thomson .....            | 5, 1    |
| Providence Christian ..... | 6, 3      | Haralson County .....    | 0, 1    |
| North Cobb Christian ..... | 3, 6      | Callaway .....           | 0, 0    |

### Round 2

|                            |         |                            |         |
|----------------------------|---------|----------------------------|---------|
| Mt. Paran .....            | 3, 7    | Model .....                | 1, 1    |
| Jeff Davis .....           | 6, 5    | Toombs County .....        | 0, 1    |
| Fellowship Christian ..... | 7, 16   | Walker .....               | 2, 2    |
| Brantley County .....      | 9, 13   | Fitzgerald .....           | 5, 1    |
| Appling County .....       | 6, 13   | Worth County .....         | 1, 2    |
| Redan .....                | 10, 6   | Rockmart .....             | 5, 5    |
| Cook .....                 | 0, 9, 5 | Vidalia .....              | 4, 8, 0 |
| North Cobb Christian ..... | 5, 10   | Providence Christian ..... | 0, 3    |

### Quarterfinals

|                            |         |                       |         |
|----------------------------|---------|-----------------------|---------|
| Mt. Paran .....            | 2, 2    | Jeff Davis .....      | 0, 0    |
| Fellowship Christian ..... | 4, 7    | Brantley County ..... | 0, 2    |
| Appling County .....       | 0, 5, 2 | Redan .....           | 7, 2, 1 |
| North Cobb Christian ..... | 4, 6    | Cook .....            | 2, 3    |

### Semifinals

|                            |      |                            |      |
|----------------------------|------|----------------------------|------|
| Mt. Paran .....            | 7, 6 | Fellowship Christian ..... | 1, 0 |
| North Cobb Christian ..... | 3, 5 | Appling County .....       | 1, 3 |

### Final

|                            |          |                 |         |
|----------------------------|----------|-----------------|---------|
| North Cobb Christian ..... | 4, 0, 11 | Mt. Paran ..... | 2, 6, 1 |
|----------------------------|----------|-----------------|---------|

### Class A, Div. 1

#### Round 1

|                       |        |                         |       |
|-----------------------|--------|-------------------------|-------|
| King's Ridge .....    | 15, 11 | Oglethorpe County ..... | 0, 1  |
| Commerce .....        | 8, 9   | Pepperell .....         | 2, 5  |
| Crawford County ..... | 6, 15  | Bryan County .....      | 3, 3  |
| Irwin County .....    | 5, 16  | Jefferson County .....  | 0, 0  |
| Social Circle .....   | 24, 6  | St. Francis .....       | 11, 0 |
| Elbert County .....   | 4, 11  | Trion .....             | 0, 2  |

|                          |        |                      |       |
|--------------------------|--------|----------------------|-------|
| Lamar County .....       | 4, 7   | Screven County ..... | 1, 1  |
| Bleckley County .....    | 11, 15 | Brooks County .....  | 1, 0  |
| Swainsboro .....         | 8, 8   | Pelham .....         | 0, 2  |
| Metter .....             | 4, 12  | Temple .....         | 0, 0  |
| Athens Christian .....   | 3, 9   | Armuchee .....       | 1, 1  |
| Prince Avenue .....      | 6, 24  | Mt. Vernon .....     | 1, 2  |
| Bacon County .....       | 8, 7   | Dublin .....         | 4, 6  |
| Heard County .....       | 11, 19 | Claxton .....        | 1, 1  |
| Darlington .....         | 10, 11 | Tallulah Falls ..... | 0, 0  |
| Whitefield Academy ..... | 11, 26 | Jasper County .....  | 1, 13 |

### Round 2

|                       |          |                          |          |
|-----------------------|----------|--------------------------|----------|
| King's Ridge .....    | 11, 9, 6 | Commerce .....           | 16, 5, 0 |
| Irwin County .....    | 13, 5    | Crawford County .....    | 3, 4     |
| Social Circle .....   | 8, 10    | Elbert County .....      | 7, 0     |
| Bleckley County ..... | 13, 0, 5 | Lamar County .....       | 3, 11, 0 |
| Metter .....          | 15, 13   | Swainsboro .....         | 0, 0     |
| Prince Avenue .....   | 4, 10    | Athens Christian .....   | 3, 0     |
| Heard County .....    | 3, 7     | Bacon County .....       | 2, 1     |
| Darlington .....      | 4, 12    | Whitefield Academy ..... | 2, 4     |

### Quarterfinals

|                       |          |                     |          |
|-----------------------|----------|---------------------|----------|
| Irwin County .....    | 3, 13    | King's Ridge .....  | 2, 2     |
| Bleckley County ..... | 6, 6     | Social Circle ..... | 3, 4     |
| Prince Avenue .....   | 9, 11, 9 | Metter .....        | 11, 3, 7 |
| Darlington .....      | 4, 11    | Heard County .....  | 1, 5     |

### Semifinals

|                     |       |                       |      |
|---------------------|-------|-----------------------|------|
| Irwin County .....  | 8, 10 | Bleckley County ..... | 4, 3 |
| Prince Avenue ..... | 10, 6 | Darlington .....      | 3, 4 |

### Final

|                     |      |                    |      |
|---------------------|------|--------------------|------|
| Prince Avenue ..... | 4, 9 | Irwin County ..... | 0, 1 |
|---------------------|------|--------------------|------|

### Class A, Div. 2

#### Round 1

|                            |          |                          |         |
|----------------------------|----------|--------------------------|---------|
| Georgia Military .....     | 14, 17   | Marion County .....      | 5, 1    |
| Bowdon .....               | 6, 3, 5  | Lincoln County .....     | 1, 5, 1 |
| McIntosh County .....      | 7, 5     | Wheeler County .....     | 0, 2    |
| Seminole County .....      | 11, 12   | Echols County .....      | 10, 4   |
| Johnson County .....       | 9, 9     | Taylor County .....      | 0, 2    |
| Washington-Wilkes .....    | BYE      |                          |         |
| Jenkins County .....       | 8, 12    | Treutlen .....           | 0, 1    |
| Charlton County .....      | 5, 13    | Early County .....       | 4, 5    |
| Lanier County .....        | 6, 11    | Miller County .....      | 5, 8    |
| ECI .....                  | 7, 13    | Hawkinsville .....       | 1, 0    |
| Towns County .....         | 13, 10   | Mt Zion-Carroll .....    | 3, 1    |
| Chattahoochee County ..... | 2, 2     | Glascok County .....     | 1, 0    |
| Baconton .....             | 7, 3, 10 | Clinch County .....      | 3, 5, 5 |
| Wilcox County .....        | 13, 16   | Portal .....             | 3, 0    |
| Lake Oconee Academy .....  | 6, 3     | Christian Heritage ..... | 5, 2    |
| Schley County .....        | 10, 17   | Wilkinson County .....   | 0, 0    |

### Round 2

|                         |          |                            |         |
|-------------------------|----------|----------------------------|---------|
| Bowdon .....            | 16, 2    | Georgia Military .....     | 1, 0    |
| McIntosh County .....   | 1, 6, 5  | Seminole County .....      | 6, 1, 3 |
| Washington-Wilkes ..... | 3, 13    | Johnson County .....       | 2, 1    |
| Charlton County .....   | 15, 12   | Jenkins County .....       | 0, 2    |
| ECI .....               | 5, 14    | Lanier County .....        | 1, 3    |
| Towns County .....      | 13, 0, 8 | Chattahoochee County ..... | 3, 2, 7 |
| Wilcox County .....     | 12, 12   | Baconton .....             | 5, 1    |
| Schley County .....     | 6, 10    | Lake Oconee Academy .....  | 0, 3    |

### Quarterfinals

|                       |         |                         |         |
|-----------------------|---------|-------------------------|---------|
| McIntosh County ..... | 1, 1, 8 | Bowdon .....            | 0, 5, 7 |
| Charlton County ..... | 4, 5    | Washington-Wilkes ..... | 0, 2    |
| ECI .....             | 13, 7   | Towns County .....      | 3, 0    |
| Schley County .....   | 6, 2, 5 | Wilcox County .....     | 4, 3, 4 |

### Semifinals

|                       |       |                       |      |
|-----------------------|-------|-----------------------|------|
| Charlton County ..... | 11, 7 | McIntosh County ..... | 1, 2 |
| ECI .....             | 6, 5  | Schley County .....   | 2, 3 |

### Final

|                       |         |           |         |
|-----------------------|---------|-----------|---------|
| Charlton County ..... | 3, 4, 5 | ECI ..... | 1, 5, 0 |
|-----------------------|---------|-----------|---------|

# BASS FISHING STATE TOURNAMENT - 2023

| Team Members                             | School        | Fish | Weight |
|--|---------------|------|--------|
| 1. Bryson Dover & Angel Cornejo          | Lanier        | 5/5  | 20-08  |
| 2. Jackson Thomas & Cole Bradley         | King's Ridge  | 5/5  | 16-07  |
| 3. Madison Hawkin & Cara Perry           | Dawson County | 5/5  | 16-05  |
| 4. Churchill Harris & Campbell Patterson | Oconee County | 5/5  | 15-11  |

# STATE BASKETBALL PLAYOFFS - 2023

## 7A - GIRLS

### Round 1

Lambert 52, North Cobb 38  
Norcross 65, Collins Hill 41  
Archer 45, Hillgrove 36  
Lowndes 58, Westlake 29  
Cherokee 90, West Forsyth 67  
Buford 83, Duluth 28  
North Paulding 47, Grayson 46  
Pebblebrook 67, Richmond Hill 47  
Campbell 67, Colquitt County 35  
McEachern 61, South Gwinnett 25  
Central Gwinnett 53, North Gwinnett 44  
Walton 65, Denmark 60  
Carrollton 48, Valdosta 41  
Brookwood 75, Harrison 36  
Peachtree Ridge 56, Mill Creek 43  
South Forsyth 55, Wheeler 30

### Round 2

Norcross 59, Lambert 34  
Archer 56, Lowndes 53  
Buford 72, Cherokee 52  
North Paulding 49, Pebblebrook 39  
McEachern 50, Campbell 47  
Central Gwinnett 76, Walton 48  
Brookwood 65, Carrollton 60  
South Forsyth 54, Peachtree Ridge 35

### Quarterfinals

Norcross 61, Archer 53  
Buford 66, North Paulding 42  
McEachern 50, Central Gwinnett 47  
Brookwood 74, South Forsyth 58

### Semifinals

Norcross 58, Buford 46  
Brookwood 58, McEachern 53

### Final

Brookwood 43, Norcross 39

## 7A - BOYS

### Round 1

Osborne 54, Denmark 50  
Norcross 91, Collins Hill 67  
Newton 68, Harrison 59  
Pebblebrook 50, Lowndes 48  
Cherokee 59, West Forsyth 45  
Berkmar 58, Buford 53  
Parkview 64, Hillgrove 61  
Carrollton 77, Colquitt County 56  
Westlake 52, Camden County 43  
McEachern 66, South Gwinnett 55  
North Gwinnett 72, Mill Creek 62  
Wheeler 81, Milton 64  
Valdosta, Campbell 60  
Grayson 99, Marietta 56  
Peachtree Ridge 70, Mountain View 45  
Walton 63, Lambert 49

### Round 2

Norcross 72, Osborne 60  
Newton 73, Pebblebrook 51  
Cherokee 73, Berkmar 68  
Carrollton 58, Parkview 56  
McEachern 40, Westlake 22  
Wheeler 74, North Gwinnett 49  
Grayson 76, Valdosta 53  
Walton 64, Peachtree Ridge 56

### Quarterfinals

Norcross 58, Newton 56  
Cherokee 70, Carrollton 66  
Wheeler 79, McEachern 71  
Grayson 46, Walton 29

### Semifinals

Cherokee 63, Norcross 60

Wheeler 67, Grayson 55

### Final

Wheeler 78, Cherokee 58

## 6A - GIRLS

### Round 1

Woodstock 56, New Manchester 44  
Gainesville 70, Sprayberry 66  
Lovejoy 63, Riverwood 20  
Veterans 62, Glynn Academy 27  
Sequoyah 65, Douglas County 50  
North Forsyth 67, Pope 57  
Woodward Academy 72, St. Pius X 33  
Brunswick 71, Thomas Co. Central 36  
Lee County 44, South Effingham 30  
Rockdale County 71, Lakeside-DeKalb 23  
Habersham Cent. 53, Lassiter 40  
Hughes 55, Rome 36  
Tift County 55, Grovetown 58  
Marist 51, Forest Park 33  
Blessed Trinity 61, Shiloh 36  
River Ridge 70, Alexander 36

### Round 2

Gainesville 63, Woodstock 61  
Lovejoy 72, Veterans 53  
Sequoyah 59, North Forsyth 46  
Brunswick 64, Woodward Academy 57  
Rockdale County 65, Lee County 43  
Hughes 51, Habersham Cent. 27  
Marist 61, Tift County 37  
River Ridge 65, Blessed Trinity 47

### Quarterfinals

Lovejoy 79, Gainesville 34  
Brunswick 59, Sequoyah 47  
Hughes 61, Rockdale County 53  
River Ridge 61, Marist 43

### Semifinals

Lovejoy 73, Brunswick 62  
River Ridge 60, Hughes 46

### Final

River Ridge 68, Lovejoy 50

## 6A - BOYS

### Round 1

River Ridge 52, Hughes 50  
Blessed Trinity 68, North Forsyth 56  
Riverwood 59, Woodward Academy 58  
Lee County 61, Evans 49  
South Paulding 56, Sequoyah 54  
Lanier 67, Sprayberry 64  
Marist 72, Lovejoy 40  
Grovetown 75, Houston County 47  
Brunswick 60, Tift County 57  
Jonesboro 48, South Cobb 34  
Shiloh 64, Alpharetta 51  
Alexander 65, Rome 57  
Lakeside-Evans 63, Veterans 59  
St. Pius X 56, Rockdale County 50  
Pope 63, Habersham Cent. 56  
Etowah 79, Paulding County 51

### Round 2

Blessed Trinity 69, River Ridge 59  
Lee County 70, Riverwood 63  
Lanier 67, South Paulding 55  
Grovetown 58, Marist 51  
Jonesboro 65, Brunswick 46  
Alexander 64, Shiloh 57  
St. Pius X 62, Lakeside-Evans 57  
Etowah 59, Pope 42

### Quarterfinals

Lee County 65, Blessed Trinity 61  
Lanier 62, Grovetown 58

Alexander 54, Jonesboro 53  
Etowah 54, St. Pius X 53

### Semifinals

Lee County 49, Lanier 48  
Alexander 56, Etowah 53

### Final

Alexander 66, Lee County 42

## 5A - GIRLS

### Round 1

Cambridge 69, Banneker 54  
Calhoun 73, Heritage-Conyers 48  
Arabia Mountain 65, McIntosh 39  
Jones County 44, Ware County 36  
Midtown 52, Centennial 39  
Cartersville 53, Jefferson 44  
Harris County 51, Chamblee 33  
Warner Robins 50, Statesboro 42  
Union Grove 66, Greenbrier 58  
Northside-Columbus 84, Lithonia 9  
Dalton 51, Loganville 30  
Jackson-Atlanta 69, GACS 42  
Bradwell Institute 64, Eagles Landing 41  
Decatur 76, Northgate 29  
Hiram 68, Flowery Branch 24  
Kell 69, Lithia Springs 23

### Round 2

Calhoun 68, Cambridge 63  
Arabia Mountain 52, Jones County 36  
Midtown 41, Cartersville 30  
Warner Robins 55, Harris County 43  
Union Grove 67, Northside-Columbus 54  
Jackson-Atlanta 66, Dalton 41  
Bradwell Institute 66, Decatur 42  
Kell 50, Hiram 33

### Quarterfinals

Calhoun 62, Arabia Mountain 52  
Warner Robins 73, Midtown 62  
Jackson-Atlanta 54, Union Grove 47  
Kell 68, Bradwell Institute 55

### Semifinals

Warner Robins 62, Calhoun 53  
Kell 56, Jackson-Atlanta 37

### Final

Kell 57, Warner Robins 36

## 5A - BOYS

### Round 1

Tri-Cities 69, Cambridge 57  
Hiram 68, Heritage-Conyers 45  
Tucker 65, Northgate 45  
Jones County 65, Bradwell Institute 44  
Mays 87, North Springs 70  
Winder-Barrow 53, Cartersville 41  
Lithonia 58, Northside-Columbus 57  
Eagles Landing 80, Greenbrier 32  
Union Grove 62, Statesboro 48  
McIntosh 53, Chamblee 48  
Cass 68, Jefferson 49  
Chapel Hill 60, Chattahoochee 51  
Dutchtown 50, Coffee 39  
Decatur 66, Harris County 56  
Eastside 60, Calhoun 54  
Kell 97, Jackson-Atlanta 68

### Round 2

Hiram 93, Tri-Cities 73  
Jones County 64, Tucker 50  
Mays 69, Winder-Barrow 68  
Eagles Landing 64, Lithonia 36  
Union Grove 61, McIntosh 60  
Chapel Hill 85, Cass 52  
Dutchtown 55, Decatur 46

# STATE BASKETBALL PLAYOFFS - 2023

Kell 79, Eastside 48

## Quarterfinals

Jones County 81, Hiram 71  
Eagles Landing 81, Mays 71  
Chapel Hill 71, Union Grove 57  
Kell 73, Dutchtown 60

## Semifinals

Eagles Landing 66, Jones County 54  
Kell 54, Chapel Hill 33

## Final

Kell 61, Eagles Landing 53

## 4A - GIRLS

### Round 1

Westminster 52, Woodland-Henry 27  
NW Whitfield 58, East Hall 56  
Fayette County 56, Islands 41  
Hardaway 71, West Laurens 29  
Stockbridge 67, SW DeKalb 49  
Chestatee 61, Central-Carroll 25  
Starr's Mill 45, Wayne County 27  
Griffin 62, Bainbridge 17  
Baldwin 68, Shaw 44  
Troup 68, Burke County 54  
East Forsyth 76, Sonoraville 72  
Luella 67, Hapeville 23  
Westover 58, Howard 32  
Trinity Christian 88, SE Bulloch 52  
Heritage-Catoosa 48, North Hall 40  
Holy Innocents' 82, Pace Academy 34

### Round 2

NW Whitfield 56, Westminster 54  
Hardaway 60, Fayette County 30  
Chestatee 66, Stockbridge 56  
Griffin 60, Starr's Mill 30  
Baldwin 62, Troup County 46  
Luella 89, East Forsyth 29  
Trinity Christian 49, Westover 42  
Holy Innocents' 79, Heritage-Catoosa 42

## Quarterfinals

Hardaway 48, NW Whitfield 22  
Griffin 66, Chestatee 47  
Baldwin 57, Luella 51  
Holy Innocents' 63, Trinity Christian 32

## Semifinals

Griffin 59, Hardaway 54  
Baldwin 58, Holy Innocents' 45

## Final

Griffin 51, Baldwin 47

## 4A - BOYS

### Round 1

McDonough 66, Holy Innocents' 57  
Sonoraville 71, Seckinger 59  
SE Bulloch 70, Whitewater 67  
Westover 69, Spalding 66  
Pace Academy 67, Miller Grove 28  
Walnut Grove 73, SE Whitfield 45  
LaGrange 74, Burke County 59  
Baldwin 55, Cairo 50  
Perry 61, Shaw 54  
Benedictine 65, Trinity Christian 47  
Madison County 74, NW Whitfield 49  
Lovett 55, Druid Hills 46  
Bainbridge 46, Westside- Macon 43  
Fayette County 98, New Hampstead 73  
North Oconee 53, Central-Carroll 52  
Woodland-Henry 55, SW DeKalb 45

### Round 2

McDonough 78, Sonoraville 38  
Westover 67, SE Bulloch 55

Pace Academy 58, Walnut Grove 41  
Baldwin 57, LaGrange 47  
Benedictine 72, Perry 59  
Madison County 49, Lovett 48  
Fayette County 61, Bainbridge 59  
Woodland-Henry 76, North Oconee 52

## Quarterfinals

Westover 66, McDonough 57  
Pace Academy 62, Baldwin 31  
Benedictine 58, Madison County 35  
Fayette County 83, Woodland-Henry 71

## Semifinals

Pace Academy 57, Westover 49  
Fayette County 73, Benedictine 67

## Final

Pace Academy 66, Fayette County 54

## 3A - GIRLS

### Round 1

Coahulla Creek 69, Douglass-Atlanta 21  
Wesleyan 79, Franklin County 29  
Morgan County 49, Long County 45  
Carver-Columbus 102, Upson-Lee 34  
Carver-Atlanta 47, Bremen 38  
Hebron Christian 68, White County 53  
Liberty County 64, Hephzibah 48  
Mary Persons 55, Thomasville 24  
Peach County 55, Dougherty 53  
Calvary Day 65, Salem 27  
Dawson County 41, Hart County 34  
Adairsville 41, Sandy Creek 36  
Monroe 53, Jackson 29  
Cross Creek 60, Savannah Country Day 55  
Lumpkin County 72, Oconee County 47  
Lakeview-Ft. Ogle. 69, Cedar Grove 28

### Round 2

Wesleyan 83, Coahulla Creek 33  
Carver-Columbus 94, Morgan County 31  
Hebron Christian 75, Carver-Atlanta 23  
Mary Persons 47, Liberty County 43  
Calvary Day 57, Peach County 49  
Dawson County 58, Adairsville 37  
Cross Creek 52, Monroe 49  
Lumpkin County 66, Lakeview-Ft. Ogle. 32

## Quarterfinals

Wesleyan 78, Carver-Columbus 72  
Hebron Christian 98, Mary Persons 25  
Calvary Day 59, Dawson County 32  
Lumpkin County 63, Cross Creek 48

## Semifinals

Hebron Christian 65, Wesleyan 58  
Lumpkin County 78, Calvary Day 31

## Final

Hebron Christian 68, Lumpkin County 36

## 3A - BOYS

### Round 1

Douglass-Atlanta 61, Lakeview-Ft. Ogle. 52  
Hebron Christ. 74, White County 55  
Harlem 57, Beach 56  
Dougherty 90, Mary Persons 37  
Cedar Grove 73, LaFayette 53  
Monroe Area 80, Pickens 57  
Long County 82, Salem 71  
Upson-Lee 72, Carver-Columbus 70  
Crisp County 66, Jackson 64  
Johnson-Savannah 107, Hephzibah 45  
Wesleyan 59, Stephens County 48  
Sandy Creek 100, Ringgold 57  
Monroe 68, Peach County 33  
Cross Creek 86, Groves 63  
Hart County 83, Gilmer 77

Adairsville 80, Carver-Atlanta 56

## Round 2

Douglass-Atlanta 74, Hebron Christian 43  
Dougherty 76, Harlem 59  
Cedar Grove 62, Monroe Area 55  
Long County 71, Upson-Lee 68  
Johnson-Savannah 78, Crisp County 54  
Sandy Creek 68, Wesleyan 22  
Cross Creek 65, Monroe 54  
Hart County 68, Adairsville 60

## Quarterfinals

Douglass-Atlanta 78, Dougherty 73  
Cedar Grove 95, Long County 92  
Sandy Creek 56, Johnson-Savannah 50  
Cross Creek 72, Hart County 65

## Semifinals

Cedar Grove 61, Douglass-Atlanta 45  
Sandy Creek 54, Cross Creek 35

## Final

Sandy Creek 66, Cedar Grove 38

## 2A - GIRLS

### Round 1

KIPP Atlanta 62, Callaway 50  
Murray County 59, Union County 38  
Josey 52, Vidalia 22  
Dodge County 71, ACE Charter 26  
North Cobb Christian 48, Columbia 39  
Banks County 60, North Murray 27  
Laney 64, Brantley County 46  
Central, Macon 50, Worth County 16  
Northeast-Macon 81, Berrien 48  
Butler 48, Tattall County 47  
Fannin County 62, Athens Academy 37  
Landmark Christ. 73, Washington 42  
Spencer 72, Fitzgerald 69  
Thomson 59, Pierce County 22  
Model 50, East Jackson 38  
Mt. Paran 83, ELCA 17

### Round 2

Murray County 61, KIPP Atlanta 56  
Josey 47, Dodge County 40  
Banks County 53, North Cobb Christian 35  
Central, Macon 73, Laney 54  
Butler 42, Northeast-Macon 39  
Landmark Christ. 79, Fannin County 55  
Thomson 64, Spencer 34  
Mt. Paran 55, Model 22

## Quarterfinals

Josey 47, Murray County 38  
Banks County 61, Central-Macon 56  
Landmark Christian 66, Butler 42  
Mt. Paran 54, Thomson 43

## Semifinals

Banks County 48, Josey 44  
Mt. Paran 58, Landmark Christian 51

## Final

Mt. Paran 67, Banks County 44

## 2A - BOYS

### Round 1

Washington 68, Callaway 62  
Model 76, Athens Acad. 57  
Putnam County 71, Toombs County 49  
Dodge County 60, Rutland 41  
NC Christian 59, Redan 56  
Providence 89, Rockmart 51  
Butler 59, Tattall County 44  
Spencer 83, Cook 46  
Central-Macon 67, Fitzgerald 49

# STATE BASKETBALL PLAYOFFS - 2023

Windsor Forest 72, Thomson 68  
Union County 85, Murray County 63  
Columbia 63, Drew Charter 50  
Sumter County 62, Northeast-Macon 47  
Westside-Augusta 77, Vidalia 32  
North Murray 72, Banks County 61  
South Atlanta 55, Landmark Christian 53

## Round 2

Model 52, Washington 44  
Dodge County 85, Putnam County 82  
Providence 78, North Cobb Christian 74  
Spencer 56, Butler 54  
Windsor Forest 72, Central-Macon 50  
Columbia 83, Union County 41  
Westside-Augusta 82, Sumter County 49  
South Atlanta 72, North Murray 63

## Quarterfinals

Model 62, Dodge County 60  
Providence 84, Spencer 70  
Columbia 74, Windsor Forest 60  
Westside-Augusta 81, South Atlanta 50

## Semifinals

Providence 59, Model 49  
Westside-Augusta 55, Columbia 52

## Final

Westside-Augusta 85, Providence 81

## A. Division 1 - GIRLS

### Round 1

Galloway 72, Social Circle 27  
Darlington 57, Tallulah Falls 36  
Screven County 43, Heard County 41  
Pelham 57, Bleckley County 19  
Mt. Pisgah 59, Prince Avenue 52  
Elbert County 61, Trion 28  
Temple 55, Bryan County 50  
Swainsboro 57, Brooks County 21  
Dublin 42, Bacon County 31  
Woodville-Tompkins 63, Crawford Co. 38  
Rabun County 74, Pepperell 37  
Oglethorpe County 45, Paideia 37  
East Laurens 64, Irwin County 47  
Lamar County 56, Savannah 40  
Athens Christian 67, Chattooga 45  
St. Francis 96, Jasper County 11

### Round 2

Galloway 64, Darlington 35  
Pelham 48, Screven County 37  
Elbert County 77, Mt. Pisgah 71  
Swainsboro 63, Temple 52  
Woodville-Tompkins 67, Dublin 33  
Oglethorpe County 51, Rabun County 50  
Lamar County 76, East Laurens 62  
St. Francis 90, Athens Christian 54

## Quarterfinals

Galloway 71, Pelham 36  
Elbert County 63, Swainsboro 49  
Woodville-Tomp. 64, Oglethorpe County 44  
St. Francis 84, Lamar County 45

## Semifinals

Galloway 70, Elbert County 57  
St. Francis 76, Woodville-Tompkins 36

## Final

St. Francis 76, Galloway 74

## A. Division 1 - BOYS

### Round 1

Mt. Pisgah 52, Prince Avenue 45  
Darlington 75, Elbert County 51  
Heard County 70, Bryan County 56  
Irwin County 51, Jefferson County 48  
Mt. Bethel 61, Oglethorpe County 56  
Athens Christian 71, Dade County 55  
Savannah 76, Crawford County 43  
Swainsboro 87, Bacon County 36  
Pelham 77, East Laurens 75  
Woodville-Tompkins 60, Lamar County 33  
Rabun County 54, Trion 42  
King's Ridge 69, Social Circle 60  
Dublin 60, Brooks County 43  
Temple 80, Screven County 51  
Chattooga 60, Tallulah Falls 57  
Mt. Vernon 96, Jasper County 52

### Round 2

Mt. Pisgah 78, Darlington 66  
Irwin County 72, Heard County 64  
Athens Christian 74, Mt. Bethel 68  
Swainsboro 57, Savannah 54  
Woodville-Tompkins 81, Pelham 62  
King's Ridge 65, Rabun County 30  
Temple 70, Dublin 61  
Mt. Vernon 87, Chattooga 49

## Quarterfinals

Mt. Pisgah 69, Irwin County 55  
Swainsboro 70, Athens Christian 55  
King's Ridge 62, Woodville-Tompkins 54  
Mt. Vernon 68, Temple 38

## Semifinals

Mt. Pisgah 53, Swainsboro 49  
King's Ridge 53, Mt. Vernon 48

## Final

King's Ridge 68, Mt. Pisgah 58

## A. Division 2 - GIRLS

### Round 1

Macon County 61, GA Military 14  
Mt Zion-Carroll 42, Warren County 29  
Wilcox County 54, McIntosh County 44  
Early County 45, Echols County 30  
Schley County 67, Glascock County 37  
Lake Oconee Academy 76, Bowdon 32  
Telfair County 48, Jenkins County 33  
Turner County 61, Mitchell County 36  
Clinch County 59, Calhoun County 32  
Montgomery County 55, Treutlen 37  
Towns County 49, Christian Heritage 38  
Chatt. County 73, Johnson County 67  
Randolph-Clay 54, Charlton County 49  
Hawkinsville 47, Emanuel County 29  
Greene County 47, Greenforest 43  
Taylor County 72, Twiggs County 17

### Round 2

Mt Zion-Carroll 57, Macon County 46  
Wilcox County 48, Early County 46

Lake Oconee Academy 63, Schley County 34  
Turner County 69, Telfair County 42  
Clinch County 57, Montgomery County 41  
Towns County 66, Chatt. County 57  
Randolph-Clay 37, Hawkinsville 30  
Taylor County 65, Greene County 49

## Quarterfinals

Mt Zion-Carroll 46, Wilcox County 38  
Lake Oconee Academy 58, Turner County 23  
Clinch County 56, Towns County 41  
Taylor County 64, Randolph-Clay 35

## Semifinals

Lake Oconee Acad. 34, Mt Zion-Carroll 14  
Clinch County 63, Taylor County 55

## Final

Clinch County 45, Lake Oconee Acad. 42

## A. Division 2 - BOYS

### Round 1

Manchester 76, GA Military 45  
Greenforest Christ. 80, Towns County 37  
McIntosh County 85, Hawkinsville 44  
Calhoun County 87, Atkinson County 32  
Hancock Central 60, Chattahoochee Co. 52  
SWAC 62, Warren County 56  
Telfair County 64, Jenkins County 57  
Charlton County 66, Early County 32  
Randolph-Clay 50, Turner County 43  
Portal 77, Treutlen 68  
Fulton Leadership 59, Aquinas 51  
Wilkinson County 85, Greenville 37  
Mitchell County 65, Clinch County 60  
Dooly County 58, Montgomery County 52  
Christian Heritage 73, Lincoln County 46  
Macon County 102, Twiggs County 64

### Round 2

Greenforest 60, Manchester 56  
Calhoun County 66, McIntosh County 37  
Hancock Cent. 50, SWAC 48  
Charlton County 79, Telfair County 42  
Portal 62, Randolph-Clay 44  
Wilkinson County 79, Fulton Leadership 52  
Dooly County 60, Mitchell County 56  
Macon County 66, Christian Heritage 61

## Quarterfinals

Greenforest 67, Calhoun County 60  
Charlton County 68, Hancock Central 45  
Wilkinson County 46, Portal 42  
Macon County 71, Dooly County 65

## Semifinals

Charlton County 50, Greenforest 49  
Wilkinson County 85, Macon County 63

## Final

Wilkinson County 40, Charlton County 36

## AAASP Championship

Houston County 49, DeKalb County 30

# STATE CROSS COUNTRY MEET - 2022-23

## Boys - 7A

|                      |               |          |
|----------------------|---------------|----------|
| 1. Memphis Rich      | Richmond Hill | 16:21.93 |
| 2. Jared Fortenberry | Marietta      | 16:38.93 |
| 3. Will Jennings     | Carrollton    | 16:39.92 |
| 4. Cory Chambers     | Milton        | 16:47.29 |

### Team Scores

|                 |     |
|-----------------|-----|
| 1. Marietta     | 88  |
| 2. Carrollton   | 122 |
| 3. Lambert      | 134 |
| 4. West Forsyth | 137 |

## Boys - 6A

|                  |        |          |
|------------------|--------|----------|
| 1. Tommy Latham  | Marist | 15:58.17 |
| 2. Dru Moore     | Etowah | 16:22.31 |
| 3. Andrew Balogh | Etowah | 16:22.92 |
| 4. Tucker Wright | Rome   | 16:36.27 |

### Team Scores

|                  |     |
|------------------|-----|
| 1. North Atlanta | 98  |
| 2. Pope          | 106 |
| 3. Roswell       | 136 |
| 4. Marist        | 137 |

## Boys - 5A

|                    |                |          |
|--------------------|----------------|----------|
| 1. Diego Santiago  | Chattahoochee  | 16:49.26 |
| 2. Jake Westing    | Decatur        | 17:02.13 |
| 3. Beck Wolf-Hardy | Clarke Central | 17:04.10 |
| 4. William Carlton | Decatur        | 17:09.01 |

### Team Scores

|                   |     |
|-------------------|-----|
| 1. Decatur        | 93  |
| 2. Clarke Central | 98  |
| 3. Chattahoochee  | 146 |
| 4. Jones County   | 208 |

## Boys - 4A

|                   |                 |          |
|-------------------|-----------------|----------|
| 1. Alex Arrambide | East Forsyth    | 16:03.82 |
| 2. Joe Sapone     | Holy Innocents' | 16:22.10 |
| 3. Esfan Daya     | Westminster     | 16:30.90 |
| 4. Joseph Jacquot | Westminster     | 16:37.26 |

### Team Scores

|                 |     |
|-----------------|-----|
| 1. Westminster  | 54  |
| 2. Starr's Mill | 66  |
| 3. Clarkston    | 138 |
| 4. Pace Academy | 183 |

## Boys - 3A

|                     |                      |          |
|---------------------|----------------------|----------|
| 1. Aaron Brodrick   | Oconee County        | 16:35.87 |
| 2. Cooper Timberman | Oconee County        | 16:51.75 |
| 3. John Ryan        | Savannah Country Day | 17:09.04 |
| 4. Wyatt Windham    | Lumpkin County       | 17:13.65 |

### Team Scores

|                  |     |
|------------------|-----|
| 1. Oconee County | 51  |
| 2. Wesleyan      | 115 |
| 3. Pike County   | 146 |
| 4. Pickens       | 154 |

## Boys - 2A

|                    |                |          |
|--------------------|----------------|----------|
| 1. Simon Schabort  | Model          | 16:16.51 |
| 2. Jackson Scruggs | Athens Academy | 17:22.16 |
| 3. Pepper Davis    | Banks County   | 17:28.90 |
| 4. Hayden Hodges   | East Jackson   | 17:31.56 |

### Team Scores

|                   |     |
|-------------------|-----|
| 1. Athens Academy | 70  |
| 2. Model          | 119 |
| 3. Jeff Davis     | 133 |
| 4. Fannin County  | 141 |

## Boys - 1A Div. 1

|                    |                    |          |
|--------------------|--------------------|----------|
| 1. Luke Churchwell | Bleckley County    | 16:35.98 |
| 2. Taylor Wade     | Whitefield Academy | 16:36.03 |
| 3. Nathan Smith    | Athens Christian   | 16:48.97 |
| 4. Haris Flynn     | Mt. Vernon         | 17:02.23 |

### Team Scores

|                       |     |
|-----------------------|-----|
| 1. Armuchee           | 61  |
| 2. Whitefield Academy | 67  |
| 3. Paideia            | 96  |
| 4. Athens Christian   | 109 |

## Boys - 1A Div. 2

|                  |                          |          |
|------------------|--------------------------|----------|
| 1. Diego Pryor   | Aquinas                  | 18:36.00 |
| 2. Joe Meier     | Georgia Military College | 18:48.50 |
| 3. Eli Walker    | Aquinas                  | 19:02.80 |
| 4. Liam Corbally | Atlanta Classical        | 19:14.80 |

### Team Scores

|                             |     |
|-----------------------------|-----|
| 1. Atkinson County          | 66  |
| 2. Georgia Military College | 66  |
| 3. Atlanta Classical        | 84  |
| 4. Aquinas                  | 111 |

## Girls - 7A

|                      |               |          |
|----------------------|---------------|----------|
| 1. Samantha McGarity | Harrison      | 18:34.91 |
| 2. Maddie Jones      | Marietta      | 19:15.03 |
| 3. Carmel Yonas      | South Forsyth | 19:24.26 |
| 4. Bella Cammarota   | Lambert       | 19:28.18 |

### Team Scores

|                  |     |
|------------------|-----|
| 1. Marietta      | 33  |
| 2. Harrison      | 101 |
| 3. South Forsyth | 156 |
| 4. Walton        | 191 |

## Girls - 6A

|                    |           |          |
|--------------------|-----------|----------|
| 1. Hannah Schemmel | St. Pius  | 19:12.92 |
| 2. Claire Shelton  | Dunwoody  | 19:13.50 |
| 3. Ruby Little     | Marist    | 19:31.92 |
| 4. Katelynn Dollar | Creekview | 19:32.76 |

### Team Scores

|                    |     |
|--------------------|-----|
| 1. Marist          | 67  |
| 2. St. Pius        | 81  |
| 3. Blessed Trinity | 95  |
| 4. Sequoyah        | 164 |

## Girls - 5A

|                      |                 |          |
|----------------------|-----------------|----------|
| 1. Gabriella Malerba | Decatur         | 20:29.38 |
| 2. Grace Danser      | Jackson-Atlanta | 20:36.78 |
| 3. Lottie Chappell   | North Springs   | 20:38.86 |
| 4. Anna Blaich       | Decatur         | 20:50.38 |

### Team Scores

|              |     |
|--------------|-----|
| 1. Decatur   | 29  |
| 2. Midtown   | 111 |
| 3. McIntosh  | 121 |
| 4. Cambridge | 142 |

## Girls - 4A

|                     |              |          |
|---------------------|--------------|----------|
| 1. Palmer Walstad   | Westminster  | 19:08.38 |
| 2. Caroline Hood    | Pace Academy | 19:36.29 |
| 3. Clodagh O'Bryant | North Hall   | 19:54.17 |
| 4. Zahara Bernal    | Pace Academy | 20:07.12 |

### Team Scores

|                 |    |
|-----------------|----|
| 1. Pace Academy | 34 |
| 2. North Hall   | 50 |
| 3. Starr's Mill | 74 |
| 4. Westminster  | 84 |

## Girls - 3A

|                       |              |          |
|-----------------------|--------------|----------|
| 1. Nealeigh Broadwell | White County | 20:35.23 |
| 2. Bekah Wise         | Pickens      | 20:42.58 |
| 3. Gabby Ware         | Columbus     | 20:50.38 |
| 4. Eva Murphy         | Wesleyan     | 20:55.57 |

### Team Scores

|                  |     |
|------------------|-----|
| 1. Wesleyan      | 48  |
| 2. Oconee County | 99  |
| 3. Mary Persons  | 106 |
| 4. Columbus      | 114 |

## Girls - 2A

|                   |                    |          |
|-------------------|--------------------|----------|
| 1. Margaret Wade  | Savannah Arts      | 19:27.12 |
| 2. Shari Brown    | Landmark Christian | 19:46.88 |
| 3. Maya Davis     | Athens Academy     | 19:55.90 |
| 4. Sarah Harrison | Athens Academy     | 20:10.01 |

### Team Scores

|                         |     |
|-------------------------|-----|
| 1. Savannah Arts        | 41  |
| 2. Athens Academy       | 62  |
| 3. Landmark Christian   | 97  |
| 4. Fellowship Christian | 152 |

## Girls - 1A Div. 1

|                   |                 |          |
|-------------------|-----------------|----------|
| 1. Ella Gibbs     | Bleckley County | 18:57.53 |
| 2. Marissa Kimple | Armuchee        | 19:07.61 |
| 3. Shelby Green   | Armuchee        | 19:19.78 |
| 4. Sophia Cook    | Coosa           | 20:19.53 |

### Team Scores

|                       |     |
|-----------------------|-----|
| 1. Bleckley County    | 60  |
| 2. Paideia            | 106 |
| 3. Oglethorpe County  | 109 |
| 4. Whitefield Academy | 154 |

## Girls - 1A Div. 2

|                       |                    |          |
|-----------------------|--------------------|----------|
| 1. Isidora Catron     | Wilcox County      | 23:04.03 |
| 2. Geisha Smith       | Seminole County    | 23:22.45 |
| 3. Sara Neil Kirkland | Atlanta Classical  | 23:31.57 |
| 4. Sirena Pridgen     | Christian Heritage | 23:37.19 |

### Team Scores

|                         |     |
|-------------------------|-----|
| 1. Atlanta Classical    | 61  |
| 2. Chattahoochee County | 104 |
| 3. Wilcox County        | 122 |
| 4. Atkinson County      | 170 |



# STATE COMPETITIVE CHEERLEADING - 2022-23

**7A**

- Lambert.....104.0
- North Paulding.....102.0
- Richmond Hill.....100.5
- Hillgrove.....100.0

**6A**

- Houston County.....107.0
- North Forsyth.....104.0
- Lanier.....100.0
- Allatoona.....97.5

**5A**

- McIntosh.....106.0
- Cartersville.....104.0
- Northgate.....100.0
- Greenbrier.....95.5

**4A**

- Whitewater.....103.0
- West Laurens.....102.5
- Starr's Mill.....100.5
- Central-Carroll.....94.5

**3A**

- Savannah Christian.....102.0
- Mary Persons.....96.0
- Gordon Lee.....94.5
- Columbus.....94.0

**2A**

- Mt. Paran.....96.0
- Pierce County.....95.5
- KIPP Atlanta.....90.5
- Fellowship Christian.....82.5

**1A**

- Armuchee.....91.5
- Pepperell.....90.0
- Commerce.....90.0
- Bleckley County.....89.0

**CO-ED**

- Mill Creek.....110.0
- Chapel Hill.....108.5
- Milton.....106.0
- Lakeside-Evans.....103.0

## GAME DAY STATE WINNERS - 2022-23

**7A**

- Buford.....93.30
- North Gwinnett.....92.13
- Mill Creek.....90.07
- Richmond Hill.....88.73

**5A-6A**

- South Effingham.....96.17
- Lee County.....94.63
- Lanier.....94.33
- Callhoun.....85.57

**3A-4A**

- Mary Persons.....91.90
- West Laurens.....91.17
- Cedartown.....90.70
- Wayne County.....88.30

**A-2A**

- Vidalia.....95.10
- Commerce.....88.90
- Pepperell.....88.77
- Toombs County.....87.17

**DANCE**

- Mill Creek.....85.73
- McIntosh.....84.15
- Buford.....82.40
- Lee County.....72.03

## DANCE STATE WINNERS - 2022-23

**7A**

- P'tree Ridge (Hip Hop).....97.93
- Mill Creek (Pom).....94.50
- Lambert (Hip Hop).....93.45
- S. Forsyth (Hip Hop).....92.60

**5A-6A**

- McIntosh (Jazz).....97.70
- Etowah (Jazz).....94.23
- Creekside (Hip Hop).....90.63
- Tri-Cities (Hip Hop).....86.40

**3A-4A**

- Starr's Mill (Pom).....93.18
- Lakeview-Ft Ogl. (H. Hop).....91.65
- Cairo (Hip Hop).....90.60
- North Oconee (Pom).....88.93

**A-2A**

- Stilwell Arts (Jazz).....95.03
- Washington (Hip Hop).....87.30
- Murray Co. (Hip Hop).....80.93
- Barrow (Hip Hop).....80.78

## STATE GIRLS GYMNASTICS - 2023

### Class 6A-7A

#### Team Results

- Buford.....114.825
- Carrollton.....111.700
- Forsyth Central.....111.100
- North Forsyth.....111.100

#### Individual Results

##### All Around

- Marissa Ashton, Buford (39.575)
- Mani Fofana, West Forsyth (38.850)
- Katie Andrews, Forsyth Central (38.575)
- Amber Lowe, Allatoona (38.400)

##### Uneven Parallel Bars

- Marissa Ashton, Buford (9.825)
- Logan Otteson, North Forsyth (9.775)
- Amber Lowe, Allatoona (9.525)
- Katie Andrews, Forsyth Central (9.500)

##### Balance Beam

- Marissa Ashton, Buford (9.850)
- Mani Fofana, West Forsyth (9.650)
- Alyssa Strain, Allatoona (9.400)
- Amber Lowe, Allatoona (9.300)

### Floor Exercise

- Marissa Ashton, Buford (10.000)
- Lily Black, Buford (10.000)
- Katie Andrews, Forsyth Central (9.900)
- Amber Lowe, Allatoona (9.575)

### Vault

- Amber Lowe, Allatoona (10.000)
- Logan Otteson, North Forsyth (10.000)
- Mani Fofana, West Forsyth (10.000)
- Katie Andrews, Forsyth Central (9.925)

### Class A-5A

#### Team Results

- North Oconee.....112.375
- Oconee County.....109.825
- Bremen.....108.050
- Villa Rica.....103.300

#### Individual Results

##### All Around

- Hannah Aoki, Oconee County (38.225)
- Anjali Roy, Cambridge (37.075)
- McCall McMullen, North Oconee (36.925)
- Hannah Shultz, Bremen (36.800)

### Uneven Parallel Bars

- Sienna Zuccaro, North Oconee (9.600)
- Hannah Aoki, Oconee County (9.350)
- Emory Shepherd, North Oconee (9.200)
- Elenor Pichetto, Oconee County (9.050)

### Balance Beam

- Emily Gittemeier, North Oconee (9.600)
- Anjali Roy, Cambridge (9.575)
- Ella Thurman, Cambridge (9.525)
- McCall McMullen, North Oconee (9.400)

### Floor Exercise

- Hannah Aoki, Oconee County (9.950)
- Kate Stetter, North Oconee (9.300)
- Nyla Loyd, Stephenson (9.225)
- Chloe McDonald, North Oconee (9.175)

### Vault

- Hannah Aoki, Oconee County (9.950)
- Sienna Zuccaro, North Oconee (9.900)
- Elenor Pichetto, Oconee County (9.850)
- McCall McMullen, North Oconee (9.600)

# FOOTBALL STANDINGS - 2022

| REGION                  | ALL | REGION                    | ALL | REGION | ALL                   |     |      |
|-------------------------|-----|---------------------------|-----|--------|-----------------------|-----|------|
| W L                     | W L | W L                       | W L | W L    | W L                   |     |      |
| <b>1-A-A-A-A-A-A</b>    |     | Riverwood                 | 2-3 | 2-8    | Northview             | 0-6 | 1-9  |
| Colquitt County         | 4-0 | Dunwoody                  | 2-4 | 5-5    | <b>7-A-A-A-A-A</b>    |     |      |
| Camden County           | 3-1 | Lakeside-DeKalb           | 0-1 | 8-2    | Calhoun               | 4-1 | 7-3  |
| Valdosta                | 2-2 | South Cobb                | 0-5 | 0-10   | Cartersville          | 4-1 | 9-1  |
| Lowndes                 | 1-3 |                           |     |        | Dalton                | 3-2 | 5-5  |
| Richmond Hill           | 0-4 | <b>5-A-A-A-A-A</b>        |     |        | Cass                  | 2-3 | 4-6  |
| <b>2-A-A-A-A-A-A</b>    |     | Hughes                    | 7-0 | 10-0   | Hiram                 | 2-3 | 5-5  |
| Carrollton              | 4-0 | South Paulding            | 6-1 | 7-3    | Woodland-Bartow       | 0-5 | 1-9  |
| Westlake                | 3-1 | Douglas County            | 5-2 | 7-3    | <b>8-A-A-A-A-A</b>    |     |      |
| East Coweta             | 2-2 | Paulding County           | 4-3 | 6-4    | Jefferson             | 6-0 | 8-2  |
| Pebblebrook             | 1-3 | Newnan                    | 3-4 | 4-6    | Loganville            | 5-1 | 9-1  |
| Campbell                | 0-4 | Alexander                 | 2-5 | 3-7    | Clarke Central        | 4-2 | 5-5  |
| <b>3-A-A-A-A-A-A</b>    |     | East Paulding             | 1-6 | 3-7    | Eastside              | 3-3 | 6-4  |
| Marietta                | 3-1 | New Manchester            | 0-7 | 0-10   | Winder-Barrow         | 2-4 | 5-5  |
| North Paulding          | 3-1 |                           |     |        | Flowerly Branch       | 1-5 | 3-7  |
| Harrison                | 2-2 | <b>6-A-A-A-A-A</b>        |     |        | Heritage-Conyers      | 0-6 | 2-8  |
| Hillgrove               | 1-3 | Rome                      | 6-0 | 9-1    | <b>1-A-A-A-A</b>      |     |      |
| McEachern               | 1-3 | Sequoyah                  | 4-2 | 5-5    | Bainbridge            | 4-0 | 6-4  |
| <b>4-A-A-A-A-A-A</b>    |     | Allatoona                 | 4-2 | 5-5    | Cairo                 | 3-1 | 7-3  |
| Brookwood               | 4-1 | Creekview                 | 3-3 | 4-6    | Westover              | 1-3 | 3-7  |
| Grayson                 | 4-1 | River Ridge               | 3-3 | 6-4    | Hardaway              | 1-3 | 2-8  |
| Newton                  | 3-2 | Etowah                    | 1-5 | 5-5    | Shaw                  | 1-3 | 4-6  |
| Parkview                | 3-2 | Woodstock                 | 0-6 | 0-10   | <b>2-A-A-A-A</b>      |     |      |
| Archer                  | 1-4 |                           |     |        | Perry                 | 6-0 | 9-1  |
| South Gwinnett          | 0-5 | <b>7-A-A-A-A-A</b>        |     |        | Spalding              | 4-2 | 6-4  |
| <b>5-A-A-A-A-A-A</b>    |     | Roswell                   | 6-0 | 9-1    | Baldwin               | 3-3 | 4-6  |
| North Cobb              | 5-0 | Alpharetta                | 5-1 | 7-3    | Griffin               | 3-3 | 3-7  |
| Walton                  | 4-1 | Blessed Trinity           | 4-2 | 7-3    | Westside-Macon        | 3-3 | 7-3  |
| Wheeler                 | 2-3 | Sprayberry                | 3-3 | 4-6    | Howard                | 2-4 | 6-4  |
| Cherokee                | 2-3 | Johns Creek               | 1-5 | 2-8    | West Laurens          | 0-6 | 1-9  |
| Kennesaw Mountain       | 2-3 | Pope                      | 1-5 | 1-9    | <b>3-A-A-A-A</b>      |     |      |
| Osborne                 | 0-5 | Lassiter                  | 1-5 | 3-7    | Benedictine           | 5-0 | 8-2  |
| <b>6-A-A-A-A-A-A</b>    |     | <b>8-A-A-A-A-A</b>        |     |        | Wayne County          | 4-1 | 8-2  |
| Milton                  | 5-0 | Gainesville               | 6-0 | 10-0   | Burke County          | 3-2 | 8-2  |
| Lambert                 | 4-1 | North Forsyth             | 5-1 | 7-3    | New Hampstead         | 2-3 | 6-4  |
| South Forsyth           | 3-2 | Shiloh                    | 4-2 | 5-5    | Southeast Bulloch     | 1-4 | 2-8  |
| Denmark                 | 2-3 | Lanier                    | 3-3 | 4-6    | Islands               | 0-5 | 0-10 |
| West Forsyth            | 1-4 | Jackson County            | 2-4 | 3-7    | <b>4-A-A-A-A</b>      |     |      |
| Forsyth Central         | 0-5 | Habersham Central         | 1-5 | 3-7    | Troup County          | 6-1 | 9-1  |
| <b>7-A-A-A-A-A-A</b>    |     | Apalachee                 | 0-6 | 0-10   | Whitewater            | 5-2 | 8-2  |
| North Gwinnett          | 6-0 | <b>1-A-A-A-A-A</b>        |     |        | Trinity Christian     | 5-2 | 6-4  |
| Norcross                | 5-1 | Ware County               | 5-0 | 9-0    | LaGrange              | 5-2 | 8-2  |
| Meadowcreek             | 4-2 | Coffee                    | 4-1 | 8-2    | Starr's Mill          | 4-3 | 7-3  |
| Peachtree Ridge         | 3-3 | Jenkins                   | 3-2 | 4-6    | Riverdale             | 2-5 | 3-7  |
| Discovery               | 2-4 | Statesboro                | 2-3 | 3-7    | Fayette County        | 1-6 | 1-9  |
| Duluth                  | 1-5 | Bradwell Institute        | 1-4 | 1-9    | North Clayton         | 0-7 | 1-9  |
| Berkmar                 | 0-6 | Greenbrier                | 0-5 | 0-10   | <b>5-A-A-A-A</b>      |     |      |
| <b>8-A-A-A-A-A-A</b>    |     | <b>2-A-A-A-A-A</b>        |     |        | Stockbridge           | 7-0 | 8-2  |
| Buford                  | 5-0 | Warner Robins             | 5-1 | 6-4    | Lovett                | 6-1 | 6-4  |
| Mill Creek              | 4-1 | Dutchtown                 | 5-1 | 9-1    | Pace Academy          | 5-2 | 8-2  |
| Collins Hill            | 2-3 | Ola                       | 4-2 | 6-4    | Hampton               | 4-3 | 7-3  |
| Dacula                  | 2-3 | Jones County              | 4-2 | 6-4    | Woodland, Stockbridge | 3-4 | 5-5  |
| Mountain View           | 2-3 | Union Grove               | 2-4 | 4-6    | Luella                | 1-6 | 1-9  |
| Central Gwinnett        | 0-5 | Eagle's Landing           | 1-5 | 2-8    | Mt. Zion, Jonesboro   | 1-6 | 1-9  |
| <b>1-A-A-A-A-A-A</b>    |     | Locust Grove              | 0-6 | 0-10   | McDonough             | 1-6 | 2-8  |
| Thomas County Central   | 4-0 | <b>3-A-A-A-A-A</b>        |     |        | <b>6-A-A-A-A</b>      |     |      |
| Northside-Warner Robins | 3-1 | Northside, Columbus       | 4-0 | 9-1    | Stephenson            | 4-1 | 6-3  |
| Lee County              | 3-2 | Northgate                 | 3-1 | 4-6    | Holy Innocents'       | 4-1 | 7-3  |
| Houston County          | 3-2 | McIntosh                  | 2-2 | 5-5    | Westminster           | 3-2 | 6-4  |
| Veterans                | 1-4 | Harris County             | 1-3 | 2-8    | Hapeville             | 2-3 | 2-8  |
| Tift County             | 0-5 | Drew                      | 0-4 | 0-10   | Miller Grove          | 2-3 | 4-6  |
| <b>2-A-A-A-A-A-A</b>    |     | <b>4-A-A-A-A-A</b>        |     |        | Southwest DeKalb      | 0-5 | 2-8  |
| Brunswick               | 6-0 | Decatur                   | 5-0 | 6-4    | Stone Mountain#       | 0-0 | 5-5  |
| Effingham County        | 5-1 | Chamblee                  | 4-1 | 7-2    | Druid Hills#          | 0-0 | 4-6  |
| Glynn Academy           | 4-2 | Arabia Mountain           | 3-2 | 5-5    | Clarkston#            | 0-0 | 2-8  |
| Evans                   | 2-4 | Tucker                    | 2-3 | 4-6    | <b>7-A-A-A-A</b>      |     |      |
| South Effingham         | 2-4 | M.L. King                 | 1-4 | 2-8    | Cedartown             | 5-0 | 0-0  |
| Lakeside-Evans          | 1-5 | Lithonia                  | 0-5 | 0-10   | Central-Carroll       | 3-2 | 7-3  |
| Grovetown               | 1-5 | Cross Keys#               | 0-0 | 1-7    | Sonoraville           | 3-2 | 6-4  |
| <b>3-A-A-A-A-A-A</b>    |     | <b>5-A-A-A-A-A</b>        |     |        | Heritage, Catoosa     | 3-2 | 8-2  |
| Lovejoy                 | 6-1 | Creekside                 | 7-0 | 8-2    | Northwest Whitfield   | 1-4 | 5-5  |
| Woodward Academy        | 6-1 | Lithia Springs            | 5-2 | 6-4    | Southeast Whitfield   | 0-5 | 4-6  |
| Mundy's Mill            | 5-2 | Mays                      | 5-2 | 6-4    | <b>8-A-A-A-A</b>      |     |      |
| Morrow                  | 4-3 | Jackson-Atlanta           | 5-2 | 7-3    | North Oconee          | 8-0 | 10-0 |
| Alcovy                  | 3-4 | Villa Rica                | 3-4 | 4-6    | Walnut Grove          | 6-2 | 8-2  |
| Jonesboro               | 2-5 | Bancker                   | 2-5 | 4-6    | Cedar Shoals          | 5-3 | 5-5  |
| Forest Park             | 2-5 | Chapel Hill               | 1-6 | 3-7    | Madison County        | 5-3 | 6-4  |
| Rockdale County         | 0-7 | Tri-Cities                | 0-7 | 1-9    | East Forsyth          | 4-4 | 6-4  |
| <b>4-A-A-A-A-A-A</b>    |     | Midtown#                  | 0-0 | 5-5    | North Hall            | 3-5 | 3-7  |
| Marist                  | 5-0 | <b>6-A-A-A-A-A</b>        |     |        | Cherokee Bluff        | 3-5 | 3-7  |
| St. Pius X              | 4-1 | Cambridge                 | 6-0 | 8-2    | Chestatee             | 2-6 | 2-8  |
| North Atlanta           | 3-2 | Kell                      | 5-1 | 9-1    | East Hall             | 0-8 | 2-8  |
|                         |     | Centennial                | 4-2 | 5-5    | Johnson, Gainesville# | 0-0 | 1-9  |
|                         |     | Greater Atlanta Christian | 3-3 | 5-5    |                       |     |      |
|                         |     | Chattahoochee             | 2-4 | 3-7    |                       |     |      |
|                         |     | North Springs             | 1-5 | 4-6    |                       |     |      |

# FOOTBALL STANDINGS - 2022

|                          | REGION<br>W L | ALL<br>W L |                           | REGION<br>W L | ALL<br>W L |   | REGION<br>W L | ALL<br>W L |
|--------------------------|---------------|------------|---------------------------|---------------|------------|---|---------------|------------|
| Seckinger#               | 0-0           | 0-7        | Vidalia                   | 2-4           | 6-4        | Chattahoochee County                          | 3-3           | 4-5        |
| <u>1-AAA</u>             |               |            | Windsor Forest            | 0-6           | 1-9        | Greenville                                    | 2-4           | 2-7        |
| Thomasville              | 5-0           | 7-3        | <u>4-AA</u>               |               |            | Marion County                                 | 2-5           | 2-8        |
| Carver-Columbus          | 4-1           | 7-2        | Thomson                   | 7-0           | 9-1        | Taylor County                                 | 1-6           | 2-8        |
| Dougherty                | 3-2           | 8-2        | Putnam County             | 6-1           | 8-2        | Central-Talbotton                             | 0-4           | 0-7        |
| Crisp County             | 2-3           | 5-5        | Laney                     | 5-2           | 8-2        | <u>7-A, Division 2</u>                        |               |            |
| Monroe                   | 1-4           | 5-5        | Washington County         | 4-3           | 4-6        | Bowdon  | 2-0           | 8-1        |
| Columbus                 | 0-5           | 2-8        | Westside-Augusta          | 2-5           | 2-8        | Mt. Zion-Carroll                              | 1-1           | 5-5        |
| <u>2-AAA</u>             |               |            | Glenn Hills               | 2-5           | 3-7        | Christian Heritage                            | 0-2           | 4-6        |
| Peach County             | 4-0           | 7-3        | Josey                     | 1-5           | 2-7        | <u>8-A, Division 2</u>                        |               |            |
| Jackson                  | 2-2           | 5-5        | Butler                    | 0-6           | 2-7        | Lincoln County                                | 5-0           | 8-2        |
| Upson-Lee                | 2-2           | 4-6        | <u>5-AA</u>               |               |            | Washington-Wilkes                             | 3-2           | 7-3        |
| Mary Persons             | 2-2           | 6-4        | Callaway                  | 6-0           | 7-3        | Greene County                                 | 3-2           | 6-4        |
| Pike County              | 0-4           | 2-8        | Eagle's Landing Christian | 5-1           | 6-4        | Aquinas                                       | 3-2           | 7-3        |
| <u>3-AAA</u>             |               |            | Columbia                  | 4-2           | 7-3        | Towns County                                  | 1-4           | 3-7        |
| Calvary Day School       | 7-0           | 9-0        | Landmark Christian        | 3-3           | 5-5        | Warren County                                 | 0-5           | 2-8        |
| Savannah Christian       | 6-1           | 9-1        | McNair                    | 2-4           | 4-6        | Lake Oconee Academy#                          | 0-0           | 4-5        |
| Long County              | 4-3           | 6-4        | Redan                     | 1-5           | 2-8        | Georgia School for Innovation#                | 0-0           | 0-9        |
| Liberty County           | 4-3           | 6-4        | Towers                    | 0-6           | 0-9-1      | <u>1-A, Division 1</u>                        |               |            |
| Savannah Country Day     | 3-4           | 5-5        | <u>6-AA</u>               |               |            | Irwin County                                  | 3-0           | 8-1        |
| Johnson-Savannah         | 3-4           | 5-5        | South Atlanta             | 6-0           | 1-0        | Brooks County                                 | 2-1           | 7-2        |
| Beach                    | 1-6           | 1-9        | North Cobb Christian      | 5-1           | 9-1        | Pelham  | 1-2           | 3-7        |
| Groves                   | 0-7           | 1-9        | Mt. Paran Christian       | 4-2           | 4-5        | Bacon County                                  | 0-3           | 1-9        |
| <u>4-AAA</u>             |               |            | Washington                | 2-4           | 2-7        | <u>2-A, Division 1</u>                        |               |            |
| Harlem                   | 5-0           | 9-1        | Therrell                  | 2-4           | 6-4        | Swainsboro                                    | 4-0           | 9-0        |
| Morgan County            | 4-1           | 7-3        | KIPP Atlanta Collegiate   | 1-5           | 1-8        | Dublin  | 3-1           | 6-3        |
| Hephzibah                | 3-2           | 6-4        | B.E.S.T Academy           | 1-5           | 1-7-1      | Bleckley County                               | 2-2           | 8-2        |
| Salem                    | 2-3           | 2-8        | Walker#                   | 0-0           | 1-8        | Jefferson County                              | 1-3           | 2-8        |
| Richmond Academy         | 1-4           | 4-6        | <u>7-AA</u>               |               |            | East Laurens                                  | 0-4           | 1-9        |
| Cross Creek              | 0-5           | 1-9        | Rockmart                  | 6-0           | 8-2        | <u>3-A, Division 1</u>                        |               |            |
| <u>5-AAA</u>             |               |            | Model                     | 4-2           | 6-4        | Metter  | 4-0           | 7-3        |
| Cedar Grove              | 3-0           | 7-2        | North Murray              | 4-2           | 6-4        | Screven County                                | 3-1           | 8-1        |
| Sandy Creek              | 2-1           | 8-2        | Fannin County             | 4-2           | 6-4        | Bryan County                                  | 2-2           | 6-4        |
| Carver, Atlanta          | 1-2           | 6-3        | Haralson County           | 2-4           | 3-7        | Claxton                                       | 1-3           | 4-6        |
| Douglass-Atlanta         | 0-3           | 3-7        | Gordon Central            | 1-5           | 1-9        | Savannah                                      | 0-4           | 0-10       |
| <u>6-AAA</u>             |               |            | Murray County             | 0-6           | 0-10       | <u>4-A, Division 1</u>                        |               |            |
| Adairsville              | 7-0           | 9-1        | <u>8-AA</u>               |               |            | Lamar County                                  | 3-0           | 9-1        |
| Ringgold                 | 6-1           | 7-3        | Fellowship Christian      | 5-0           | 8-2        | Heard County                                  | 2-1           | 5-5        |
| Coahulla Creek           | 5-2           | 7-3        | Athens Academy            | 4-1           | 8-2        | Crawford County                               | 1-2           | 3-6        |
| Bremen                   | 4-3           | 5-5        | Union County              | 3-2           | 7-3        | Temple  | 0-3           | 4-6        |
| Gordon Lee               | 3-4           | 4-6        | East Jackson              | 2-3           | 5-5        | <u>5-A, Division 1</u>                        |               |            |
| LaFayette                | 2-5           | 3-7        | Banks County              | 1-4           | 5-5        | Prince Avenue Christian                       | 3-0           | 9-0        |
| Lakeview-Ft. Oglethorpe  | 1-6           | 2-8        | Providence Christian      | 0-5           | 2-8        | Social Circle                                 | 2-1           | 7-3        |
| Ridgeland                | 0-7           | 0-10       | <u>1-A, Division 2</u>    |               |            | Jasper County                                 | 1-2           | 4-6        |
| <u>7-AAA</u>             |               |            | Early County              | 6-0           | 7-3        | Oglethorpe County                             | 0-3           | 5-5        |
| Dawson County            | 6-0           | 8-2        | Mitchell County           | 4-2           | 5-5        | <u>6-A, Division 1</u>                        |               |            |
| Pickens                  | 4-2           | 5-5        | Miller County             | 4-2           | 5-5        | St. Francis                                   | 3-0           | 6-4        |
| Lumpkin County           | 4-2           | 8-2        | Terrell County            | 3-3           | 4-6        | Mt. Pisgah Christian                          | 2-1           | 7-3        |
| Wesleyan                 | 3-3           | 4-6        | Seminole County           | 3-3           | 4-6        | Whitefield Academy                            | 1-2           | 6-4        |
| White County             | 2-4           | 4-6        | Randolph-Clay             | 1-5           | 1-9        | Mount Vernon                                  | 0-3           | 4-6        |
| Gilmer                   | 2-4           | 5-5        | Baconton                  | 0-6           | 1-9        | King's Ridge#                                 | 0-0           | 1-7        |
| West Hall                | 0-6           | 1-9        | Pataula Charter#          | 0-0           | 6-3        | <u>7-A, Division 1</u>                        |               |            |
| <u>8-AAA</u>             |               |            | <u>2-A, Division 2</u>    |               |            | Darlington                                    | 6-0           | 10-0       |
| Stephens County          | 4-1           | 8-2        | Charlton County           | 4-0           | 7-2        | Trion   | 5-1           | 8-2        |
| Oconee County            | 3-2           | 6-4        | Clinch County             | 3-1           | 7-3        | Pepperell                                     | 4-2           | 6-4        |
| Monroe Area              | 3-2           | 5-5        | Lanier County             | 2-2           | 5-5        | Dade County                                   | 3-3           | 6-4        |
| Hebron Christian Academy | 3-2           | 8-2        | Turner County             | 1-3           | 2-8        | Coosa   | 1-5           | 3-7        |
| Hart County              | 2-3           | 5-5        | Atkinson County           | 0-4           | 2-8        | Chattooga                                     | 1-5           | 2-8        |
| Franklin County          | 0-5           | 0-10       | <u>3-A, Division 2</u>    |               |            | Armuchee                                      | 1-5           | 3-7        |
| <u>1-AA</u>              |               |            | McIntosh County Academy   | 4-0           | 9-1        | <u>8-A, Division 1</u>                        |               |            |
| Fitzgerald               | 6-0           | 10-0       | Jenkins County            | 3-1           | 7-3        | Rabun County                                  | 3-0           | 10-0       |
| Cook                     | 4-2           | 7-3        | Emanuel County Institute  | 2-2           | 4-6        | Elbert County                                 | 2-1           | 9-1        |
| Worth County             | 4-2           | 8-2        | Montgomery County         | 1-3           | 4-6        | Commerce                                      | 1-2           | 6-4        |
| Dodge County             | 3-3           | 4-6        | Portal                    | 0-4           | 4-6        | Athens Christian                              | 0-3           | 3-6        |
| Berrien                  | 3-3           | 7-3        | <u>4-A, Division 2</u>    |               |            | # - Indicates team played non-region schedule |               |            |
| Jeff Davis               | 1-5           | 1-9        | Wilcox County             | 5-0           | 7-3        | * - Indicates team had to forfeit games       |               |            |
| Sumter County            | 0-6           | 1-9        | Telfair County            | 4-1           | 8-2        |   |               |            |
| <u>2-AA</u>              |               |            | Dooly County              | 3-2           | 4-6        |   |               |            |
| Spencer                  | 7-0           | 8-2        | Hawkinsville              | 1-4           | 3-7        |   |               |            |
| Northeast                | 6-1           | 7-3        | Treutlen                  | 1-4           | 1-9        |   |               |            |
| ACE Charter              | 5-2           | 8-2        | Wheeler County            | 1-4           | 4-6        |   |               |            |
| Central, Macon           | 3-4           | 3-7        | <u>5-A, Division 2</u>    |               |            |   |               |            |
| Southwest                | 3-4           | 3-7        | Johnson County            | 5-0           | 10-0       |   |               |            |
| Rutland                  | 3-4           | 5-5        | Georgia Military College  | 3-2           | 4-6        |   |               |            |
| Kendrick                 | 1-6           | 1-9        | Hancock Central           | 3-2           | 4-6        |   |               |            |
| Jordan                   | 0-7           | 0-10       | Wilkinson County          | 3-2           | 6-4        |   |               |            |
| <u>3-AA</u>              |               |            | Glascok County            | 1-4           | 2-8        |   |               |            |
| Appling County           | 6-0           | 8-1        | Twiggs County             | 0-5           | 2-8        |   |               |            |
| Pierce County            | 5-1           | 9-1        | <u>6-A, Division 2</u>    |               |            |   |               |            |
| Tattnall County          | 3-3           | 5-5        | Schley County             | 7-0           | 8-2        |   |               |            |
| Toombs County            | 3-3           | 6-4        | Manchester                | 5-1           | 6-3        |   |               |            |
| Brantley County          | 2-4           | 5-5        | Macon County              | 5-2           | 6-4        |   |               |            |

# STATE FOOTBALL PLAYOFFS - 2022

## Class 7A

| First Round             |                         |
|-------------------------|-------------------------|
| Lambert .....45         | Wheeler .....14         |
| North Gwinnett .....37  | Dacula .....7           |
| Harrison .....21        | Brookwood .....17       |
| Colquitt County .....56 | Pebblebrook .....16     |
| Walton .....35          | South Forsyth .....21   |
| Buford .....63          | Peachtree Ridge .....6  |
| Marietta .....35        | Newton .....0           |
| Carrollton .....38      | Lowndes .....14         |
| Westlake .....28        | Valdosta .....13        |
| Parkview .....34        | North Paulding .....28  |
| Mill Creek .....59      | Meadowcreek .....15     |
| North Cobb .....42      | Denmark .....10         |
| Camden County .....44   | East Coweta .....33     |
| Grayson .....30         | Hillgrove .....3        |
| Norcross .....37        | Mountain View .....13   |
| Milton .....28          | Cherokee .....14        |
| Round 2                 |                         |
| North Gwinnett .....38  | Lambert .....35         |
| Colquitt County .....49 | Harrison .....28        |
| Walton .....42          | Buford .....35          |
| Carrollton .....47      | Marietta .....14        |
| Westlake .....30        | Parkview .....28        |
| Mill Creek .....43      | North Cobb .....7       |
| Grayson .....28         | Camden County .....10   |
| Milton .....30          | Norcross .....23        |
| Quarterfinals           |                         |
| Colquitt County .....52 | North Gwinnett .....17  |
| Carrollton .....52      | Walton .....27          |
| Mill Creek .....38      | Westlake .....14        |
| Milton .....35          | Grayson .....12         |
| Semifinals              |                         |
| Carrollton .....35      | Colquitt County .....27 |
| Mill Creek .....48      | Milton .....14          |
| Final                   |                         |
| Mill Creek .....70      | Carrollton .....35      |

## Class 6A

| First Round             |                         |
|-------------------------|-------------------------|
| Allatoona .....24       | Douglas County .....0   |
| Roswell .....55         | Lanier .....8           |
| St. Pius X .....27      | Mundy's Mill .....21    |
| Thomas Co. Cent. ....49 | Evans .....10           |
| South Paulding .....28  | Sequoyah .....13        |
| Gainesville .....51     | Sprayberry .....21      |
| North Atlanta .....30   | Lovejoy .....17         |
| Houston County .....29  | Brunswick .....28       |
| Lee County .....57      | Effingham County .....7 |
| Woodward Acad. ....41   | Riverwood .....13       |
| North Forsyth .....24   | Blessed Trinity .....21 |
| Hughes .....49          | River Ridge .....6      |
| Northside-WR .....18    | Glynn Academy .....13   |
| Marist .....46          | Morrow .....8           |
| Alpharetta .....28      | Shiloh .....26          |
| Rome .....49            | Paulding County .....0  |
| Round 2                 |                         |
| Roswell .....49         | Allatoona .....30       |
| Thomas Co. Cent. ....49 | St. Pius X .....14      |
| Gainesville .....42     | South Paulding .....21  |
| Houston County .....41  | North Atlanta .....31   |
| Woodward Acad. ....23   | Lee County .....7       |
| Hughes .....77          | North Forsyth .....16   |
| Marist .....32          | Northside-WR .....13    |
| Rome .....35            | Alpharetta .....14      |
| Quarterfinals           |                         |
| Roswell .....42         | Thomas Co. Cent. ....34 |
| Gainesville .....49     | Houston County .....35  |
| Hughes .....56          | Woodward Acad. ....28   |
| Rome .....17            | Marist .....7           |
| Semifinals              |                         |
| Gainesville .....35     | Roswell .....28         |
| Hughes .....42          | Rome .....3             |
| Finals                  |                         |
| Hughes .....35          | Gainesville .....28     |

## Class 5A

| First Round           |                         |
|-----------------------|-------------------------|
| Kell .....38          | Lithia Springs .....22  |
| Calhoun .....23       | Eastside .....21        |
| Chamblee .....61      | McIntosh .....13        |
| Ware County .....55   | Jones County .....13    |
| Mays .....44          | Centennial .....16      |
| Cass .....27          | Jefferson .....17       |
| Northgate .....38     | Arabia Mtn. ....14      |
| Dutchtown .....45     | Statesboro .....0       |
| Warner Robins .....31 | Jenkins .....13         |
| Northside-Col. ....35 | Tucker .....27          |
| Dalton .....37        | Loganville .....3       |
| Creekside .....54     | GACS .....16            |
| Coffee .....34        | Ola .....6              |
| Decatur .....20       | Harris County .....20   |
| Cartersville .....43  | Clarke Central .....10  |
| Cambridge .....27     | Jackson-Atlanta .....20 |
| Round 2               |                         |
| Calhoun .....34       | Kell .....7             |
| Ware County .....24   | Chamblee .....7         |
| Mays .....34          | Cass .....27            |
| Dutchtown .....41     | Northgate .....14       |
| Warner Robins .....38 | Northside-Col. ....7    |
| Creekside .....61     | Dalton .....0           |
| Coffee .....51        | Decatur .....23         |
| Cartersville .....37  | Cambridge .....14       |
| Quarterfinals         |                         |
| Ware County .....35   | Calhoun .....0          |
| Dutchtown .....40     | Mays .....34            |
| Warner Robins .....31 | Creekside .....28       |
| Cartersville .....56  | Coffee .....28          |
| Semifinals            |                         |
| Ware County .....31   | Dutchtown .....7        |
| Warner Robins .....35 | Cartersville .....10    |
| Final                 |                         |
| Ware County .....38   | Warner Robins .....13   |

## Class 4A

| First Round             |                           |
|-------------------------|---------------------------|
| Stephenson .....40      | Pace Academy .....38      |
| Cedartown .....49       | Cedar Shoals .....0       |
| Burke County .....23    | LaGrange .....20          |
| Bainbridge .....58      | Baldwin .....20           |
| Lovett .....13          | Westminster .....6        |
| North Oconee .....49    | Sonoraville .....6        |
| Wayne County .....31    | Trinity Christian .....13 |
| Perry .....40           | Shaw .....6               |
| Spalding .....26        | Westover .....7           |
| Benedictine .....34     | Whitewater .....10        |
| Walnut Grove .....17    | Heritage-Catoosa .....13  |
| Stockbridge .....28     | Hapeville .....14         |
| Cairo .....27           | Westside-Macon .....14    |
| Troup .....36           | New Hampstead .....29     |
| Central-Carroll .....35 | Madison County .....7     |
| Holy Innocents' .....41 | Hampton .....8            |
| Round 2                 |                           |
| Cedartown .....48       | Stephenson .....16        |
| Bainbridge .....44      | Burke County .....0       |
| North Oconee .....35    | Lovett .....9             |
| Wayne County .....14    | Perry .....7              |
| Benedictine .....45     | Spalding .....6           |
| Stockbridge .....38     | Walnut Grove .....6       |
| Troup .....26           | Cairo .....17             |
| Holy Innocents' .....24 | Central-Carroll .....14   |
| Quarterfinals           |                           |
| Cedartown .....26       | Bainbridge .....21        |
| North Oconee .....31    | Wayne County .....12      |
| Benedictine .....34     | Stockbridge .....14       |
| Troup .....38           | Holy Innocents' .....28   |
| Semifinals              |                           |
| Cedartown .....28       | North Oconee .....20      |
| Benedictine .....42     | Troup .....21             |
| Final                   |                           |
| Benedictine .....14     | Cedartown .....13         |

## Class 3A

| First Round              |                            |
|--------------------------|----------------------------|
| Carver-Atlanta .....44   | Ringgold .....28           |
| Monroe Area .....35      | Dawson County .....13      |
| Liberty County .....19   | Morgan County .....14      |
| Thomasville .....42      | Jackson .....21            |
| Sandy Creek .....70      | Coahulla Creek .....14     |
| Stephens County .....51  | Wesleyan .....14           |
| Savannah Christian 41    | Hephzibah .....26          |
| Peach County .....23     | Crisp County .....0        |
| Dougherty .....39        | Mary Persons .....23       |
| Calvary Day .....49      | Salem .....0               |
| Hebron Christian .....63 | Pickens .....14            |
| Cedar Grove .....48      | Bremen .....7              |
| Carver-Columbus .....39  | Upson-Lee .....0           |
| Harlem .....35           | Long County .....0         |
| Oconee County .....49    | Lumpkin County .....21     |
| Adairsville .....55      | Douglass-Atlanta .....26   |
| Round 2                  |                            |
| Carver-Atlanta .....30   | Monroe Area .....18        |
| Thomasville .....13      | Liberty County .....6      |
| Sandy Creek .....20      | Stephens County .....7     |
| Savannah Christian 23    | Peach County .....7        |
| Calvary Day .....54      | Dougherty .....41          |
| Cedar Grove .....70      | Hebron Christian .....33   |
| Carver-Columbus .....40  | Harlem .....7              |
| Oconee County .....45    | Adairsville .....20        |
| Quarterfinals            |                            |
| Carver-Atlanta .....28   | Thomasville .....23        |
| Sandy Creek .....51      | Savannah Christian .....21 |
| Cedar Grove .....30      | Calvary Day .....0         |
| Oconee County .....14    | Carver-Columbus .....6     |
| Semifinals               |                            |
| Sandy Creek .....49      | Carver-Atlanta .....14     |
| Cedar Grove .....23      | Oconee County .....0       |
| Final                    |                            |
| Sandy Creek .....21      | Cedar Grove .....17        |

## Class 2A

| First Round             |                          |
|-------------------------|--------------------------|
| N. Cobb Christian . .14 | Columbia .....6          |
| Rockmart .....65        | East Jackson .....7      |
| Putnam County .....30   | Toombs County .....6     |
| Fitzgerald .....41      | Central-Macon .....0     |
| ELCA .....52            | Mt. Paran .....22        |
| Fellowship Christ. .49  | North Murray .....28     |
| Pierce County .....42   | Laney .....14            |
| Berrien .....43         | Spencer .....36          |
| Northeast .....41       | Worth County .....27     |
| Appling County .....65  | Washington County ..14   |
| Fannin County .....28   | Athens Academy ....13    |
| Callaway .....42        | Washington .....20       |
| Cook .....77            | ACE Charter .....35      |
| Thomson .....26         | Tattnall County .....0   |
| Union County .....28    | Model .....14            |
| South Atlanta .....44   | Landmark Christian ..21  |
| Round 2                 |                          |
| Rockmart .....63        | N. Cobb Christian ....10 |
| Fitzgerald .....28      | Putnam County .....20    |
| Fellowship Christ. .26  | ELCA .....15             |
| Pierce County .....52   | Berrien .....0           |
| Appling County .....35  | Northeast .....13        |
| Callaway .....20        | Fannin County .....13    |
| Thomson .....42         | Cook .....10             |
| South Atlanta .....42   | Union County .....14     |
| Quarterfinals           |                          |
| Fitzgerald .....21      | Rockmart .....14         |
| Fellowship Christ. .40  | Pierce County .....22    |
| Appling County .....44  | Callaway .....21         |
| Thomson .....56         | South Atlanta .....38    |
| Semifinals              |                          |
| Fitzgerald .....19      | Fellowship Christ. ....9 |
| Thomson .....20         | Appling County .....14   |
| Final                   |                          |
| Thomson .....32         | Fitzgerald .....27       |

# STATE FOOTBALL PLAYOFFS - 2022

## Class A, Div. 1

| <b>First Round</b>      |                           |
|-------------------------|---------------------------|
| Mt. Pisgah .....45      | Jasper County .....12     |
| Darlington .....45      | Athens Christian .....0   |
| Heard County .....27    | Bryan County .....16      |
| Irwin County .....42    | Jefferson County .....7   |
| Social Circle .....10   | Whitefield Academy .....7 |
| Rabun County .....47    | Dade County .....7        |
| Screven County .....35  | Crawford County .....28   |
| Swainsboro .....47      | Bacon County .....0       |
| Dublin .....55          | Pelham .....14            |
| Metter .....42          | Temple .....6             |
| Elbert County .....31   | Pepperell .....7          |
| Prince Avenue .....47   | Mt. Vernon .....14        |
| Bleckley County .....14 | Brooks County .....10     |
| Lamar County .....42    | Claxton .....21           |
| Trion .....45           | Commerce .....21          |
| St. Francis .....69     | Oglethorpe County .....7  |
| <b>Round 2</b>          |                           |
| Mt Pisgah .....26       | Darlington .....20        |
| Irwin County .....55    | Heard County .....0       |
| Rabun County .....42    | Social Circle .....0      |
| Swainsboro .....57      | Screven County .....13    |
| Metter .....18          | Dublin .....0             |
| Prince Avenue .....48   | Elbert County .....14     |

| Bleckley County .....27 | Lamar County .....23    |
|-------------------------|-------------------------|
| St. Francis .....34     | Trion .....20           |
| <b>Quarterfinals</b>    |                         |
| Irwin County .....42    | Mt. Pisgah .....14      |
| Swainsboro .....35      | Rabun County .....10    |
| Prince Avenue .....23   | Metter .....7           |
| St. Francis .....37     | Bleckley County .....21 |
| <b>Semifinals</b>       |                         |
| Swainsboro .....22      | Irwin County .....21    |
| Prince Avenue .....24   | St. Francis .....20     |
| <b>Final</b>            |                         |
| Prince Avenue .....52   | Swainsboro .....34      |

|                        |                         |
|------------------------|-------------------------|
| McIntosh Co. Acad.28   | Wheeler County .....13  |
| Christian Heritage .37 | Greene County .....6    |
| Johnson County .....34 | Chatt. County .....21   |
| Lanier County .....14  | Miller County .....13   |
| Wilcox County .....35  | Montgomery Co. ....26   |
| Wash.-Wilkes .....35   | Mt Zion-Carroll .....15 |
| Schley County .....51  | GMC .....0              |

## Class A, Div. 2

| <b>First Round</b>      |                         |
|-------------------------|-------------------------|
| Manchester .....40      | Hancock Central .....14 |
| Bowdon .....42          | Aquinas .....14         |
| Telfair County .....62  | ECI .....37             |
| Early County .....60    | Turner County .....19   |
| Wilkinson County .13    | Macon County .....7     |
| Lincoln County          | BYE                     |
| Dooly County .....22    | Jenkins County .....21  |
| Charlton County .....44 | Seminole County .....0  |
| Clinch County .....38   | Mitchell County .....15 |

| <b>Round 2</b>         |                           |
|------------------------|---------------------------|
| Bowdon .....42         | Manchester .....21        |
| Early County .....47   | Telfair County .....6     |
| Lincoln County .....42 | Wilkinson County .....8   |
| Dooly County .....14   | Charlton County .....13   |
| Clinch County .....17  | McIntosh Co. Acad. ..16   |
| Johnson County .....26 | Christian Heritage ....14 |
| Wilcox County .....44  | Lanier County .....34     |
| Schley County .....58  | Wash.-Wilkes .....14      |
| <b>Quarterfinals</b>   |                           |
| Bowdon .....36         | Early County .....26      |
| Lincoln County .....24 | Dooly County .....21      |
| Johnson County .....36 | Clinch County .....21     |
| Schley County .....55  | Wilcox County .....23     |
| <b>Semifinals</b>      |                           |
| Bowdon .....45         | Lincoln County .....28    |
| Schley County .....35  | Johnson County .....6     |
| <b>Final</b>           |                           |
| Bowdon .....39         | Schley County .....31     |

# STATE FLAG FOOTBALL PLAYOFFS - 2022

## Class 7A

| <b>Round 1</b>          |                        |
|-------------------------|------------------------|
| Milton .....27          | Woodstock .....13      |
| Peachtree Ridge ...26   | Winder-Barrow .....6   |
| Alpharetta .....7       | Brookwood .....0       |
| McEachern .....20       | Walton .....14         |
| Roswell .....13         | Forsyth Central .....6 |
| Mountain View ...26     | Norcross .....0        |
| Centennial .....12      | Shiloh .....6          |
| Allatoona .....26       | Westlake .....7        |
| Pope .....27            | Osborne .....6         |
| Grayson .....6          | Chattahoochee .....0   |
| Mill Creek .....21      | Duluth .....0          |
| Blessed Trinity ....20  | West Forsyth .....0    |
| Marietta .....20        | Wheeler .....0         |
| Archer .....25          | Dunwoody .....0        |
| North Gwinnett ....13   | Central Gwinnett ....0 |
| Lambert .....7          | Sequoyah .....6        |
| <b>Round 2</b>          |                        |
| Milton .....14          | Peachtree Ridge .....7 |
| McEachern .....26       | Alpharetta .....0      |
| Roswell .....19         | Mountain View .....6   |
| Allatoona .....26       | Centennial .....7      |
| Pope .....32            | Grayson .....12        |
| Blessed Trinity .....7  | Mill Creek .....6      |
| Marietta .....6         | Archer .....0          |
| North Gwinnett .....6   | Lambert .....0         |
| <b>Quarterfinals</b>    |                        |
| Milton .....26          | McEachern .....20      |
| Allatoona .....13       | Roswell .....6         |
| Blessed Trinity .....6  | Pope .....0            |
| Marietta .....13        | North Gwinnett .....0  |
| <b>Semifinals</b>       |                        |
| Milton .....20          | Allatoona .....13      |
| Blessed Trinity .....19 | Marietta .....0        |
| <b>Final</b>            |                        |
| Blessed Trinity .....19 | Milton .....13         |

## Class 5A-6A

| <b>Round 1</b>          |                         |
|-------------------------|-------------------------|
| Central-Carroll .....27 | Clarkston .....21       |
| Heritage-Conyers .13    | Grovetown .....7        |
| Morrow .....12          | Eagles Landing .....0   |
| Westside-Macon ...2     | Northgate .....0        |
| Villa Rica .....6       | Tucker .....0           |
| Evans .....19           | Newton .....0           |
| Luella .....31          | Mundy's Mill .....6     |
| East Coweta .....12     | Northside-WR .....6     |
| Trinity Christian ...14 | Veterans .....0         |
| McDonough .....13       | Jonesboro .....0        |
| Lakeside-Evans ...32    | Rockdale County ...0    |
| St. Pius .....7         | Paulding County ...0    |
| Starr's Mill .....18    | Warner Robins .....13   |
| Mt. Zion-Jones. ....13  | Locust Grove .....6     |
| Greenbrier .....19      | Woodland-Stock. ...0    |
| Lithia Springs .....21  | Lithonia .....0         |
| <b>Round 2</b>          |                         |
| Central-Carroll 7       | Heritage-Conyers .....6 |
| Westside-Macon .25      | Morrow .....0           |
| Evans .....19           | Villa Rica .....0       |
| East Coweta .....26     | Luella .....19          |
| Trinity Christian ...6  | McDonough .....0        |
| St. Pius .....7         | Lakeside-Evans .....6   |
| Mt. Zion-Jones. ....7   | Starr's Mill .....6     |
| Lithia Springs .....6   | Greenbrier .....0       |
| <b>Quarterfinals</b>    |                         |
| Central-Carroll .....7  | Westside-Macon ...6     |
| East Coweta .....19     | Evans .....6            |
| St. Pius .....7         | Trinity Christian ...6  |
| Lithia Springs .....20  | Mt. Zion-Jones. ....0   |
| <b>Semifinals</b>       |                         |
| Central-Carroll .....20 | East Coweta .....14     |
| Lithia Springs .....7   | St. Pius .....0         |
| <b>Final</b>            |                         |
| Lithia Springs .....14  | Central-Carroll .....0  |

## Class A-4A

| <b>Round 1</b>        |                       |
|-----------------------|-----------------------|
| North Oconee .....19  | Callaway .....0       |
| Pace Academy .....19  | Towers .....0         |
| Wheeler County .....7 | Jordan .....0         |
| Calvary Day .....12   | Sav. Country Day ..0  |
| Harris County .....27 | Athens Academy ....2  |
| Redan .....6          | Jackson-Atlanta ...0  |
| Dodge County .....7   | Sumter County .....6  |
| St. Vincents .....24  | Beach .....0          |
| New Hampstead ...33   | Lowndes .....0        |
| SE Bulloch .....40    | Spencer .....0        |
| South Atlanta .....19 | Tri-Cities .....6     |
| Northside-Col. ....0  | Walnut Grove .....0   |
| Long County .....7    | Richmond Hill .....6  |
| Columbus .....7       | Swainsboro .....6     |
| Hebron Christian ..27 | Therrell .....0       |
| Loganville .....27    | LaGrange .....6       |
| <b>Round 2</b>        |                       |
| Pace Academy .....15  | North Oconee .....0   |
| Calvary Day .....26   | Wheeler County ...12  |
| Harris County .....20 | Redan .....6          |
| St. Vincents .....24  | Dodge County .....0   |
| SE Bulloch .....19    | New Hampstead ....0   |
| Northside Col. ....27 | South Atlanta .....0  |
| Long County .....19   | Columbus .....13      |
| Loganville .....28    | Hebron Christian ...6 |
| <b>Quarterfinals</b>  |                       |
| Pace Academy .....6   | Calvary Day .....0    |
| Harris County .....7  | St. Vincents .....6   |
| SE Bulloch .....7     | Northside-Col. ....0  |
| Loganville .....27    | Long County .....7    |
| <b>Semifinals</b>     |                       |
| Harris County .....13 | Pace Academy .....6   |
| SE Bulloch .....14    | Loganville .....7     |
| <b>Final</b>          |                       |
| SE Bulloch .....13    | Harris County .....0  |

# STATE GOLF TOURNAMENTS - 2023

## 7A BOYS

### Individual Scores

1. Rohan Gopaldas, North Gwinnett...69-67
2. Luke Able, Carrollton.....65-76
3. Mason Fundingsland, Milton.....70-71
4. Evan Hanks, Lowndes.....69-73
4. Pride Dyer, West Forsyth.....74-68

### Team Scores

1. Milton.....289-281 = 570
2. Lambert.....299-278 = 577
3. Walton.....294-293 = 587
4. Lowndes.....297-291 = 588

## 7A GIRLS

### Individual Scores

1. Athena Yoo, Lambert.....71
2. Georgia Blount, Camden County.....72
3. Lindsey Pak, Peachtree Ridge.....74
3. Zoe Duval, Lambert.....74

### Team Scores

1. Lambert.....220
2. Walton.....230
3. Lowndes.....241
4. North Gwinnett.....255

## 6A BOYS

### Individual Scores

1. Williamson Mosher, Glynn Acad....69-72
2. Brant Carman, South Paulding.....70-75
3. Barrett Loftis, Lakeside-Evans.....74-72
4. Brigham Ralston, Gainesville.....75-72
4. Glover Amick, Woodward.....72-75
4. Hank Holcomb, Glynn Academy....75-72

### Team Scores

1. Glynn Academy.....293-298 = 591
2. Gainesville.....302-294 = 596
3. Johns Creek.....308-297 = 605
4. Lakeside Evans.....305-301 = 606

## 6A GIRLS

### Individual Scores

1. Mahima Vurupatur, Alpharetta.....79-72
2. Emma Hill, Glynn Academy.....79-73
3. Ella York, Johns Creek.....78-76
4. Macy Fulton, Alexander.....81-81

### Team Scores

1. Glynn Academy.....244-236 = 480
2. Alpharetta.....249-247 = 496
3. Johns Creek.....254-247 = 501
4. North Atlanta.....266-259 = 535

## 5A BOYS

### Individual Scores

1. Trace Carter, Ware County.....68-71
2. Andrew Korytoski, Harris County...72-70
3. Cole Stockard, Dalton.....73-71
4. Brody Tidwell, Cartersville.....71-74

### Team Scores

1. Cambridge.....303-297 = 600
2. Northgate.....307-303 = 610
3. Cartersville.....304-308 = 612
4. Calhoun.....311-302 = 613
4. Harris County.....311-302 = 613

## 5A GIRLS

### Individual Scores

1. Ella Manley, Calhoun.....73-73
2. Keely Johnson, Union Grove.....75-76
3. Sydney Himes, Northside, Columbus85-78
4. Adyson Lukich, Greenbrier.....82-82

## Team Scores

1. Greenbrier.....251-252 = 503
2. Northview.....252-261 = 513
3. Northside-Columbus.....270-259 = 529
4. Cambridge.....286-277 = 563

## 4A BOYS

### Individual Scores

1. Antonio Juarbe, Wayne County.....73-69
2. Zidan Ajani, Lovett.....70-74
3. Ryan Ohde, Lovett.....74-72
4. Landry Short, North Oconee.....74-74
4. Matthew Young, Westminster.....72-76

## Team Scores

1. Lovett.....298-297 = 595
2. North Oconee.....305-297 = 602
3. Wayne County.....315-299 = 614
3. Westminster.....307-307 = 614

## 4A GIRLS

### Individual Scores

1. Jessalyn Young, Westminster.....71-74
2. Kyra Dube, Westminster.....78-73
3. Haven Ward, Holy Innocents'.....74-78
4. Camryn Wright, North Oconee.....79-75

## Team Scores

1. North Oconee.....257-244 = 501
2. Westminster.....253-249 = 502
3. Starr's Mill.....258-250 = 508
4. North Hall.....261-265 = 526

## 3A BOYS

### Individual Scores

1. Brycen Jones, Thomasville.....74-68
2. Andy Scott, Wesleyan.....72-73
3. Alex Holcomb, Wesleyan.....73-73
4. Jacob Fortner, Hebron Christian.....74-73

## Team Scores

1. Wesleyan.....305-298 = 603
2. Richmond Academy.....309-317 = 626
3. Hebron Christian Academy329-306 = 635
4. Columbus.....324-315 = 639

## 3A GIRLS

### Individual Scores

1. Mary Miller, Savannah Christian....64-73
2. Kate Barber, Sav. Country Day.....70-71
3. Samantha Dewendt, Dawson Co.....70-79
4. Emma Marshall, Bremen.....72-80

## Team Scores

1. Savannah Christian.....247-241 = 488
2. White County.....264-276 = 540
3. Savannah Country Day.....275-267 = 542
4. Oconee County.....273-274 = 547

## 2A BOYS

### Individual Scores

1. Brody McQueen, Mt. Paran.....66
2. Jace Butcher, Mt. Paran.....72
3. Jb Knight, North Cobb Christian.....74
3. Zach Peterson, Mt. Paran.....74
3. Bo Shuler, ELCA.....74

## Team Scores

1. Mt. Paran.....290
2. Walker.....324
3. Banks County.....326
4. Athens Academy.....328

## 2A GIRLS

### Individual Scores

1. Mackenzie Connell, Pierce County.....73
2. Madelyn Taylor, Appling County.....76
3. Addyson Walker, Pierce County.....80
4. Lily Spivey, Pierce County.....82

### Team Scores

1. Pierce County.....153
2. Athens Academy.....183
3. Jeff Davis.....184
4. Mt. Paran Christian.....185

## A, DIVISION 1 BOYS

### Individual Scores

1. Will Baker, Prince Avenue.....70-71
2. Brady Starrett, Elbert County.....70-72
3. Maddox Drake, Prince Avenue.....72-71
4. Rocco Lopez, Darlington.....74-73

### Team Scores

1. Prince Avenue.....304-301 = 605
2. Darlington.....312-309 = 621
3. Mount Vernon.....314-309 = 623
4. Mt. Pisgah.....312-316 = 628

## A, DIVISION 1 GIRLS

### Individual Scores

1. Thanana Kotchasanmanee, Darlington..72-76
2. Claire Bradford, Prince Avenue.....75-75
3. Abby Bryant, Elbert County.....84-80
4. Ava Dye, Elbert County.....81-93

### Team Scores

1. Darlington.....168-160 = 328
2. Elbert County.....165-173 = 338
3. Prince Avenue.....172-173 = 345
4. Mt. Pisgah.....185-188 = 373

## A, DIVISION 2 BOYS

### Individual Scores

1. Colby Bennett, Lake Oconee Acad..71-71
2. Drew Williams, Lake Oconee Acad.73-71
3. Charlie Hargrove, Aquinas.....81-73
3. Rhett Smith, Lake Oconee Acad.....75-79

### Team Scores

1. Lake Oconee Academy.....302-301 = 603
2. Aquinas.....328-320 = 648
3. Christian Heritage.....338-311 = 649
4. Schley County.....358-356 = 714

## A, DIVISION 2 GIRLS

### Individual Scores

1. Kallyn Black, Lake Oconee Acad....71-69
2. Shelby Clark, Portal.....84-79
3. Georgia Bosart, Lake Oconee Acad.84-84
4. Kensley Windham, Lake Oconee Ac.88-81

### Team Scores

1. Lake Oconee Academy.....155-150 = 305
2. Hawkinsville.....196-189 = 385
3. Portal.....211-187 = 398
4. Christian Heritage.....202-201 = 403

# STATE LACROSSE TOURNAMENTS - 2023

## 6A - 7A Boys

### Round 1

South Forsyth 12, Hillgrove 7  
North Cobb 19, Collins Hill 0  
Cherokee 19, Brookwood 1  
Milton 15, E. Coweta 4  
Marietta 17, Norcross 5  
Grayson 5, Campbell 4  
N. Gwinnett 17, McEachern 1

### Round 1 Byes:

Walton, Harrison, Mtn. View,  
Lambert, West Forsyth,  
Parkview, North Paulding,  
Buford and Carrollton

### Round 2

South Forsyth 7, Walton 6  
North Cobb 10, Mtn. View 8  
Harrison 14, Cherokee 6  
Lambert 16, Milton 9  
West Forsyth 18, Parkview 2  
N. Paulding 16, Marietta 2  
Buford 18, Grayson 3  
N. Gwinnett 15, Carrollton 9

### Quarterfinals

South Forsyth 8, North Cobb 0  
Lambert 10, Harrison 3  
West Forsyth 10, N. Paulding 7  
Buford 14, N. Gwinnett 6

### Semifinals

Lambert 8, South Forsyth 7  
West Forsyth 11, Buford 10

### Final

West Forsyth 11, Lambert 9

## 5A-6A Boys

### Round 1

Centennial 10, Woodward 4  
Lakeside-Evans 19, Newnan 3  
Creekview 20, East Paulding 2  
Marist 15, Riverwood 5  
Blessed Trinity 13, Decatur 2  
McIntosh 8, Greenbrier 6  
Woodstock 9, North Forsyth 7  
Allatoona 18, Dunwoody 7  
Pope 12, St. Pius X 5  
Alpharetta 22, River Ridge 0  
Evans 4, Northgate 3  
Roswell 25, Midtown 2  
Lassiter 12, North Atlanta 5  
Etowah 21, Lanier 3  
Richmond Hill 17, Union Grove 7  
Cambridge 11, GACS 5

### Round 2

Centennial 14, Lakeside-Evans 6  
Marist 5, Creekview 4  
Blessed Trinity 18, McIntosh 1  
Allatoona 12, Woodstock 7  
Pope 12, Alpharetta 7  
Roswell 20, Evans 1  
Lassiter 11, Etowah 4  
Cambridge 16, Richmond Hill 3

## Quarterfinals

Marist 10, Centennial 9  
Allatoona 13, Blessed Trinity 12  
Roswell 17, Pope 9  
Cambridge 11, Lassiter 1

## Semifinals

Allatoona 16, Marist 7  
Roswell 20, Cambridge 12

## Final

Roswell 17, Allatoona 10

## A-4A Boys

### Round 1

Mt. Pisgah 1, N. Cobb Christ. 0  
Pace Acad. 14, Trinity Christ. 2  
Fellowship 20, Savannah Chr. 1  
Whitewater 12, Mt. Vernon 11  
North Oconee 16, Darlington 0  
Whitefield Ac. 12, Sav. Cty. Day 6  
Oconee Co. 9, Walker 5  
Hebron Chr. 12, Calvary Day 3

### Round 1 Byes:

Westminster, Mt. Paran,  
Benedictine, Wesleyan, Starr's  
Mill, King's Ridge, Lovett and  
Holy Innocents'

### Round 2

Westminster 15, Mt. Pisgah 4  
Pace Academy 16, Mt. Paran 5  
Fellowship 14, Benedictine 7  
Wesleyan 19, Whitewater 2  
Starr's Mill 14, N. Oconee 10  
King's Ridge 13, Whitefield Ac. 2  
Lovett 16, Oconee Co. 2  
Holy Innocents' 16, Hebron Chr. 5

## Quarterfinals

Westminster 11, Pace Acad. 2  
Wesleyan 13, Fellowship 12  
Starr's Mill 10, King's Ridge 4  
Lovett 14, Holy Innocents 9

## Semifinals

Westminster 11, Wesleyan 8  
Lovett 7, Starr's Mill 6

## Final

Westminster 10, Lovett 4

## 7A Girls

### Round 1

South Forsyth 13, Carrollton 9  
Marietta 18, Duluth 0  
Cherokee 20, Grayson 0  
N. Gwinnett 14, McEachern 8  
Campbell 18, Collins Hill 9  
Parkview 17, North Cobb 7  
Mill Creek 20, East Coweta 0

### Round 1 Byes:

Walton, Brookwood, Harrison,  
Milton, Lambert, Mountain

View, North Paulding, West  
Forsyth and Hillgrove

### Round 2

Walton 17, South Forsyth 7  
Brookwood 13, Marietta 7  
Cherokee 17, Harrison 10  
Milton 20, N. Gwinnett 3  
Lambert 20, Mtn. View 3  
N. Paulding 23, Campbell 4  
West Forsyth 21, Parkview 2  
Hillgrove 14, Mill Creek 7

## Quarterfinals

Walton 18, Brookwood 7  
Milton 20, Cherokee 6  
N. Paulding 12, Lambert 7  
West Forsyth 11, Hillgrove 8

## Semifinals

Milton 17, Walton 7  
West Forsyth 13, N. Paulding 4

## Final

Milton 11, West Forsyth 6

## 5A-6A Girls

### Round 1

Roswell 17, Decatur 3  
Lakeside-Evans 19, Ola 2  
River Ridge 23, East Paulding 6  
St. Pius X 16, Riverwood 7  
Cambridge 17, Northview 2  
McIntosh 16, Effingham Co. 1  
North Forsyth 15, Sequoyah 8  
Lassiter 18, Lakeside-DeKalb 6  
Kell 18, North Atlanta 2  
Alpharetta 16, Etowah 2  
Greenbrier 10, Northgate 9  
Blessed Trinity 17, Midtown 3  
Pope 22, Marist 3  
Creekview 20, Lanier 0  
Richmond Hill 14, Newnan 4  
Johns Creek 18, GACS 6

### Round 2

Roswell 13, Lakeside-Evans 6  
River Ridge 13, St. Pius X 10  
Cambridge 18, McIntosh 3  
Lassiter 14, North Forsyth 10  
Alpharetta 15, Kell 14  
Blessed Trinity 20, Greenbrier 0  
Creekview 14, Pope 6  
Johns Creek 23, Richmond Hill 2

## Quarterfinals

Roswell 16, River Ridge 8  
Cambridge 9, Lassiter 8  
Blessed Trinity 17, Alpharetta 10  
Creekview 9, Johns Creek 5

## Semifinals

Roswell 8, Cambridge 7  
Blessed Trinity 19, Creekview 8

## Final

Blessed Trinity 11, Roswell 5

## A-4A Girls

### Round 1

East Forsyth 23, McDonough 4  
Lovett 22, Trinity Christ. 3  
Mt. Pisgah 23, Woodland-Bar. 3  
Whitewater 20, ELCA 3  
North Oconee 16, Bremen 4  
Walker 9, Oconee County 8

### Round 1 Byes:

Westminster, Mt. Paran, Sav.  
Christian, Wesleyan, Starr's  
Mill, SW DeKalb, Fellowship  
Christian, Pace Academy, Holy  
Innocents' and Columbsu

### Round 2

Westminster 19, East Forsyth 3  
Mt. Paran 9, Lovett 8  
Mt. Pisgah 20, Savannah Chr. 2  
Wesleyan 9, Whitewater 6  
Starr's Mill 21, North Oconee 5  
Fellowship 18, SW DeKalb 2  
Pace Acad. 22, Walker 2  
Columbus 14, Holy Innocents' 13

## Quarterfinals

Westminster 7, Mt. Paran 3  
Wesleyan 20, Mt. Pisgah 8  
Fellowship 15, Starr's Mill 12  
Pace Acad. 14, Columbus 8

## Semifinals

Wesleyan 11, Westminster 10  
Pace Acad. 10, Fellowship 7

## Final

Pace Acad. 19, Wesleyan 12

# STATE SOCCER PLAYOFFS - 2023

## 7A - BOYS

### Round 1

S. Forsyth 3, Kennesaw Mtn. 1  
Norcross 2, Buford 0  
Archer 2, McEachern 1  
East Coweta 4, Colquitt Co. 2  
Walton 2, Milton 0  
Mill Creek 4, Berkmar 2  
Parkview 3, Harrison 0  
Pebblebrook 7, Lowndes 1  
Campbell 6, Camden Co. 0  
S. Gwinnett 2, Hillgrove 0  
Collins Hill 3, N. Gwinnett 0  
Denmark 3, Osborne 2  
Richmond Hill 3, Carrollton 2  
Brookwood 1, N. Paulding 0  
Peachtree Rdg. 5, Mtn. View 1  
Lambert 4, Wheeler 0

### Round 2

Norcross 1, South Forsyth 0  
Archer 1, East Coweta 0  
Walton 2, Mill Creek 1  
Parkview 2, Pebblebrook 1  
Campbell 2, S. Gwinnett 0  
Collins Hill 3, Denmark 2  
Richmond Hill 3, Brookwood 2  
Lambert 4, Peachtree Rdg. 1

### Quarterfinals

Archer 1, Norcross 0  
Walton 2, Parkview 1  
Collins Hill 3, Campbell 0  
Lambert 2, Richmond Hill 0

### Semifinals

Walton 2, Archer 0  
Lambert 2, Collins Hill 1

### Final

Lambert 4, Walton 3

## 7A - GIRLS

### Round 1

Denmark 3, Kennesaw Mtn. 0  
Norcross 7, Collins Hill 0  
Brookwood 1, Hillgrove 0  
Richmond Hill 7, Westlake 0  
Milton 1, Cherokee 0  
Mill Creek 1, Peachtree Rdg 0  
N. Paulding 5, Mundy's Mill 0  
Campbell 10, Colquitt Co. 0  
E. Coweta 10, Camden Co. 0  
Harrison 4, S. Gwinnett 0  
Buford 4, Meadowcreek 0  
Walton 3, West Forsyth 0  
Lowndes 4, Carrollton 0  
Archer 5, Marietta 0  
N. Gwinnett 2, Mtn. View 0  
Forsyth Central 4, Wheeler 0

### Round 2

Denmark 5, Norcross 2  
Richmond Hill 1, Brookwood 0  
Mill Creek 3, Milton 1  
Campbell 6, North Paulding 1  
Harrison 4, East Coweta 0  
Walton 2, Buford 1  
Archer 3, Lowndes 0  
Forsyth Central 6, N. Gwinnett 1

### Quarterfinals

Denmark 4, Richmond Hill 0  
Campbell 3, Mill Creek 1  
Walton 1, Harrison 0  
Forsyth Central 3, Archer 1

### Semifinals

Denmark 1, Campbell 0  
Walton 2, Forsyth Central 1

### Final

Denmark 1, Walton 0

## 6A - BOYS

### Round 1

Rome 7, Douglas Co. 1  
Lassiter 5, Habersham Cent. 1  
St. Pius X 5, Lovejoy 0  
Veterans 2, Evans 0  
Etowah 2, Alexander 1  
Johns Creek 2, Lanier 1  
Dunwoody 4, Forest Park 0  
Glynn Acad. 3, Lee Co. 0  
S. Effingham 2, Thomas Co. Cn. 1  
Lakeside-DeK. 3, Woodward 1  
Blessed Trinity 1, Gainesville 0  
S. Paulding 1, Allatoona 0  
Grovetown 6, Houston Co. 1  
Riverwood 6, Morrow 0  
Sprayberry 4, North Forsyth 3  
River Ridge 10, Newnan 0

### Round 2

Lassiter 1, Rome 0  
St. Pius X 7, Veterans 0  
Johns Creek 4, Etowah 0  
Glynn Academy 3, Dunwoody 1  
Lakeside-DeK. 1, S. Effingham 0  
Blessed Trin. 1, S. Paulding 0  
Riverwood 4, Grovetown 0  
River Ridge 3, Sprayberry 1

### Quarterfinals

Lassiter 3, St. Pius X 1  
Johns Creek 3, Glynn Acad. 0  
Blessed Trin. 3, Lakeside-DeK. 1  
River Ridge 2, Riverwood 1

### Semifinals

Lassiter 1, Johns Creek 0  
River Ridge 4, Blessed Trin. 1

### Final

Lassiter 3, River Ridge 2

## 6A - GIRLS

### Round 1

Etowah 5, Newnan 0  
Pope 10, Lanier 0  
North Atlanta 10, Alcovy 0  
Houston Co. 5, Evans 1  
River Ridge 3, S. Paulding 1  
Roswell 5, Jackson Co. 0  
St. Pius X 10, Mundy's Mill 0  
Glynn Acad. 3, Lee Co. 0  
Grovetown 3, Veterans 0  
Woodward 3, Lakeside-DeK. 1  
Lassiter 5, Habersham Cent. 0  
Sequoyah 2, Alexander 1  
Thomas Co. Cn. 5, Lakeside-Ev. 1  
Marist 10, Rockdale Co. 0  
Blessed Trin. 9, Shiloh 0  
Allatoona 8, East Paulding 0

### Round 2

Pope 4, Etowah 1  
North Atlanta 9, Houston Co. 0  
Roswell 2, River Ridge 0  
St. Pius X 7, Glynn Acad. 0  
Woodward 3, Grovetown 0  
Lassiter 6, Sequoyah 0  
Marist 9, Thomas Co. Cent 0  
Blessed Trin. 1, Allatoona 0

### Quarterfinals

Pope 1, North Atlanta 0  
Roswell 3, St. Pius X 1  
Lassiter 2, Woodward 0  
Marist 4, Blessed Trin. 1

### Semifinals

Roswell 4, Pope 0  
Marist 2, Lassiter 0

### Final

Roswell 2, Marist 0

## 5A - BOYS

### Round 1

Chattahoochee 4, Chapel Hill 0  
Dalton 4, Jefferson 0  
Chamblee 4, Harris Co. 2  
Greenbrier 8, Eagles Landing 1  
Cambridge 2, Villa Rica 1  
Flowery Branch 2, Cartersville 0  
Northgate 3, Decatur 2  
Union Grove 3, Ware Co. 0  
Statesboro 2, Dutchtown 0  
McIntosh 3, Cross Keys 2  
Clarke Cent. 2, Woodland-Bar. 0  
Midtown 3, Kell 1  
Bradwell Inst. 6, Locust Grove 1  
Tucker 2, Drew 0  
Loganville 6, Cass 1  
Centennial 8, Tri-Cities 0

### Round 2

Dalton 3, Chattahoochee 1  
Chamblee 4, Greenbrier 1  
Flowery Branch 2, Cambridge 1  
Union Grove 4, Northgate 2  
McIntosh 4, Statesboro 0  
Midtown 5, Clarke Cent. 0  
Bradwell Inst. 1, Tucker 0  
Centennial 3, Loganville 0

### Quarterfinals

Dalton 4, Chamblee 3  
Flowery Br. 1, Union Grove 0  
Midtown 2, McIntosh 0  
Centennial 5, Bradwell Inst. 1

### Semifinals

Dalton 6, Flowery Branch 0  
Midtown 1, Centennial 0

### Final

Dalton 2, Midtown 0

## 5A - GIRLS

### Round 1

Northview 3, Jackson-Atl. 1  
Dalton 3, Flowery Branch 2  
Decatur 2, Harris Co. 0  
Greenbrier 10, Locust Grove 0  
GACS 3, Villa Rica 0  
Loganville 10, Woodland-Bar. 0  
Northgate 8, Tucker 0  
Union Grove 9, Bradwell Inst. 0  
Dutchtown 3, Statesboro 1  
McIntosh 10, Arabia Mtn. 0  
Jefferson 7, Cartersville 0  
Midtown 9, Chattahoochee 2  
Ola 2, Ware Co. 1  
Chamblee 9, Northside-Col. 0  
Eastside 6, Calhoun 1  
Cambridge 8, Chapel Hill 0

### Round 2

Northview 2, Dalton 1  
Greenbrier 3, Decatur 1  
GACS 2, Loganville 1  
Northgate 3, Union Grove 0  
McIntosh 3, Dutchtown 1  
Midtown 2, Jefferson 1  
Chamblee 10, Ola 0  
Cambridge 10, Eastside 0

### Quarterfinals

Greenbrier 2, Northview 1  
Northgate 3, GACS 0  
Midtown 2, McIntosh 1  
Chamblee 6, Cambridge 3

### Semifinals

Greenbrier 1, Northgate 0  
Chamblee 3, Midtown 0

### Final

Chamblee 9, Greenbrier 0

## 4A - BOYS

### Round 1

Druid Hills 2, Pace Acad. 1  
N. Oconee 3, NW Whitfield 2  
Starr's Mill 7, SE Bulloch 0  
Cairo 8, Baldwin 2  
Holy Inn. 1, Woodland-Hen. 0  
Johnson-Gain. 9, Central-Carr. 0  
Whitewater 1, Islands 0  
Perry 3, Hardaway 1  
West Laurens 1, Shaw 0  
Benedictine 4, Troup 0  
East Hall 2, Cedartown 1  
Clarkston 1, Lovett 0  
Bainbridge 8, Spalding 0  
LaGrange 7, Wayne Co. 0  
SE Whitfield 3, Chastatee 2  
Westminster 7, Stockbridge 0

### Round 2

North Oconee 1, Druid Hills 0  
Cairo 2, Starr's Mill 1  
Johnson-Gain. 2, Holy Inn. 0  
Whitewater 2, Perry 1  
Benedictine 2, W. Laurens 1  
E. Hall 2, Clarkston 1  
LaGrange 1, Bainbridge 0  
Westminster 3, SE Whitfield 2

### Quarterfinals

N. Oconee 2, Cairo 1  
Johnson-Gain. 7, Whitewater 1  
Benedictine 3, East Hall 2  
Westminster 7, LaGrange 2

### Semifinals

Johnson-Gain. 4, N. Oconee 0  
Westminster 2, Benedictine 1

### Final

Johnson-Gain. 4, Westminster 2

## 4A - GIRLS

### Round 1

Holy Inn. 10, Woodland-Henry 0  
Heritage-Cat. 4, Madison Co. 0  
Whitewater 9, Wayne Co. 0  
Bainbridge 6, Baldwin 0  
Pace Acad. 4, Druid Hills 1  
North Oconee 10, Cedartown 0  
LaGrange 9, Islands 0  
Perry 10, Hardaway 0  
Shaw 3, West Laurens 1  
Trinity Chr. 3, SE Bulloch 2  
Cherokee Bluff 6, SE Whitfield 1  
Lovett 10, Clarkston 0  
Spalding 3, Cairo 0  
Starr's Mill 10, New Hampstead 0  
NW Whitfield 3, Johnson-Gain. 0  
Westminster 10, Mt Zion-Jones. 0

### Round 2

Holy Inn. 7, Heritage-Cat. 4  
Whitewater 5, Bainbridge 0  
North Oconee 2, Pace Acad. 0  
LaGrange 6, Perry 1  
Trinity Christian 7, Shaw 0  
Lovett 3, Cherokee Bluff 2  
Starr's Mill 9, Spalding 0  
Westminster 6, NW Whitfield 1

### Quarterfinals

Holy Innocents' 4, Whitewater 3  
North Oconee 5, LaGrange 0  
Lovett 9, Trinity Christian 0  
Westminster 6, Starr's Mill 0

### Semifinals

N. Oconee 2, Holy Innocents' 0  
Westminster 3, Lovett 2

### Final

Westminster 2, N. Oconee 1



# STATE SOCCER PLAYOFFS - 2023

## 3A - BOYS

### **Round 1**

Bremen 9, Douglass-Atlanta 1  
Wesleyan 7, Hart Co. 1  
Harlem 1, Long Co. 0  
Columbus 2, Mary Persons 1  
Ringgold 4, Cedar Grove 0  
Oconee Co. 2, Gilmer 0  
Sav. Christ. 4, Richmond Acad. 1  
Pike Co. 10, Monroe 0  
Jackson 2, Crisp Co. 1  
Sav. Cty. Day 10, Hephzibah 0  
Hebron Chr. 2, Lumpkin Co. 1  
Sandy Creek 3, Adairsville 1  
Peach Co. 7, Thomasville 4  
Morgan Co. 4, Groves 1  
West Hall 10, Franklin Co. 1  
Coahulla Creek 10, Carver-Atl. 0

### **Round 2**

Wesleyan 2, Bremen 1  
Columbus 4, Harlem 1  
Oconee Co. 7, Ringgold 0  
Pike Co. 6, Sav. Christian 1  
Sav. Cty. Day 2, Jackson 1  
Hebron Christ. 2, Sandy Creek 0  
Peach Co. 2, Morgan Co. 1  
Coahulla Creek 2, West Hall 0

### **Quarterfinals**

Wesleyan 2, Columbus 1  
Oconee Co. 1, Pike Co. 0  
Hebron Chr. 2, Sav. Cty. Day 1  
Coahulla Creek 4, Peach Co. 0

### **Semifinals**

Oconee Co. 1, Wesleyan 0  
Coahulla Creek 6, Hebron Chr. 0

### **Final**

Coahulla Creek 1, Oconee Co. 0

## 3A - GIRLS

### **Round 1**

Coahulla Cr. 10, Cedar Grove 0  
Wesleyan 8, Monroe Area 0  
Calvary Day 2, Richmond Ac. 0  
Columbus 5, Upson-Lee 0  
Adairsville 8, Douglass-Atl. 1  
Oconee Co. 5, Dawson Co. 1  
Sav. Cty. Day 10, Harlem 0  
Pike Co. 10, Carver-Col. 0  
Mary Persons 6, Crisp Co. 0  
St. Vincents 10, Salem 0  
White Co. 1, Hebron Christ. 0  
Sandy Creek 7, Ridgeland 0  
Jackson 1, Thomasville 0  
Morgan Co. 5, Long Co. 0  
Lumpkin Co. 10, Stephens Co. 0  
Bremen 10, Carver-Atlanta 0

### **Round 2**

Wesleyan 7, Coahulla Creek 0  
Columbus 6, Calvary Day 0  
Oconee Co. 10, Adairsville 0  
Sav. Cty. Day 2, Pike Co. 1  
St. Vincents 4, Mary Persons 0  
White County 7, Sandy Creek 2  
Morgan Co. 7, Jackson 1  
Bremen 5, Lumpkin Co. 1

### **Quarterfinals**

Wesleyan 1, Columbus 0  
Oconee Co. 4, Sav. Cty. Day 0  
St. Vincents 1, White County 0  
Bremen 3, Morgan Co. 0

### **Semifinals**

Oconee County 2, Wesleyan 0  
Bremen 2, St. Vincents 1

### **Final**

Oconee County 3, Bremen 1

## 2A - BOYS

### **Round 1**

Drew Charter 7, Callaway 1  
Model 2, E. Jackson 1  
Pierce Co. 7, Westside-Aug. 0  
Fitzgerald 10, Jordan 0  
Mt. Paran 6, Towers 1  
Providence 6, Gordon Cent. 0  
Savannah Arts 9, Johnson-Aug. 0

ACE Charter 4, Dodge Co. 2  
Spencer 2, Sumter County 1  
Tattnall Co. 10, Thomson 0  
Fellowship Chr. 4, Murray Co. 1  
Landmark 5, N. Cobb Chr. 2  
Rutland 3, Jeff Davis 2  
Putnam Co. 2, Toombs Co. 1  
Union Co. 1, North Murray 0  
Walker 9, ELCA 1

### **Round 2**

Model 4, Drew Charter 2  
Pierce Co. 8, Fitzgerald 2  
Providence Ch. 7, Mt. Paran 1  
ACE Charter 1, Savannah Arts 0  
Tattnall Co. 5, Spencer 1  
Fellowship Ch. 6, Landmark 4  
Putnam Co. 6, Rutland 0  
Union County 1, Walker 0

### **Quarterfinals**

Pierce Co. 3, Model 2  
Providence 8, ACE Charter 0  
Tattnall Co. 4, Fellowship Ch. 1  
Union Co. 1, Putnam Co. 0

### **Semifinals**

Providence Ch. 5, Pierce Co. 0  
Tattnall Co. 3, Union Co. 1

### **Final**

Tattnall Co. 3, Providence Ch. 2

## 2A - GIRLS

### **Round 1**

N. Cobb Christian 4, ELCA 0  
Model 5, East Jackson 1  
Appling Co. 6, Washington Co. 2  
Fitzgerald 10, Spencer 0  
Walker 3, Callaway 2  
Fellowship Ch. 10, Fannin Co. 0  
Pierce Co. 10, Thomson 0  
ACE Charter 5, Dodge Co. 3  
Worth County 2, Rutland 1  
Sav. Arts 10, Tech Career 0  
Athens Acad. 10, Murray Co. 0  
Landmark 11, Drew Charter 1  
Jeff Davis 4, Central-Macon 0  
Toombs Co. 4, Putnam Co. 0  
Union Co. 3, N. Murray 0  
Mt. Paran 10, Elite Scholars 0

### **Round 2**

Model 1, N. Cobb Christian 0  
Fitzgerald 5, Appling Co. 0  
Fellowship Chr. 10, Walker 0  
ACE Charter 2, Pierce Co. 1  
Savannah Arts 6, Worth Co. 0  
Athens Acad. 4, Landmark 0  
Toombs Co. 2, Jeff Davis 0  
Mt. Paran 6, Union Co. 1

### **Quarterfinals**

Fitzgerald 3, Model 1  
Fellowship 5, ACE Charter 0  
Athens Ac. 4, Savannah Arts 0  
Mt. Paran 3, Toombs Co. 1

### **Semifinals**

Fellowship Chr. 9, Fitzgerald 0  
Athens Acad. 5, Mt. Paran 1

### **Final**

Fellowship Chr. 5, Athens Ac. 1

## A, Div. 1 - BOYS

### **Round 1**

Atlanta Inter. 10, Prince Ave 0  
Dalton Academy 7, Rabun Co. 1  
Metter 10, Temple 0  
Bacon Co. 10, Dublin 0  
Whitefield Ac. 3, Social Circle 1  
Tallulah Falls 4, Darlington 0  
Claxton 10, Crawford Co. 0  
Bleckley Co. BYE  
East Laurens 10, Irwin Co. 0  
Woodville-Tomp. BYE  
Armuchee 3, Elbert Co. 2  
Oglethorpe Co. 2, Galloway 1  
Brooks Co. 6, Jefferson Co. 1  
Lamar Co. 8, Bryan Co. 1  
Trion 2, Barrow 0  
Paideia 9, Jasper County 0

### **Round 2**

Atlanta Inter. 6, Dalton Acad. 1  
Bacon Co. 4, Metter 0  
Whitefield Ac. 3, Tallulah Falls 1  
Claxton 3, Bleckley Co. 1  
Woodville-Tomp. 6, E. Laurens 4  
Armuchee 3, Oglethorpe Co. 1  
Lamar Co. 3, Brooks Co. 2  
Paideia 9, Trion 0

### **Quarterfinals**

Atlanta Inter. 8, Bacon Co. 1  
Whitefield Ac. 2, Claxton 0  
Armuchee 4, Woodville-Tomp. 1  
Paideia 9, Lamar Co. 0

### **Semifinals**

Atlanta Inter. 3, Whitefield Ac. 0  
Paideia 6, Armuchee 0

### **Final**

Paideia 2, Atlanta International 1

## A, Div. 1 - GIRLS

### **Round 1**

Mt. Vernon 10, Oglethorpe Co. 0  
Dade Co. 10, Elbert Co. 0  
Temple 4, Bryan Co. 1  
Bacon Co. 5, Swainsboro 0  
Atlanta Inter. 7, Prince Avenue 1  
Commerce 11, Pepperell 1  
Claxton 2, Crawford Co. 1  
Bleckley Co. BYE  
East Laurens 10, Brooks Co. 0  
Screven Co. BYE  
Tallulah Falls 3, Trion 2  
Social Circle 2, Whitefield Ac. 1  
Dublin 6, Irwin Co. 1  
Lamar Co. 9, Metter 0  
Darlington 2, Rabun Co. 0  
Paideia 10, Jasper County 0

### **Round 2**

Mt. Vernon 5, Dade Co. 3  
Temple 2, Bacon Co. 0  
Commerce 3, Atlanta Inter. 2  
Bleckley Co. 7, Claxton 0  
E. Laurens 2, Screven Co. 1  
Social Circle 5, Tallulah Falls 2  
Lamar Co. 8, Dublin 0  
Paideia 8, Darlington 0

### **Quarterfinals**

Mt. Vernon 11, Temple 1  
Commerce 10, Bleckley Co. 0  
Social Circle 4, E. Laurens 0  
Paideia 9, Lamar Co. 1

### **Semifinals**

Mt. Vernon 3, Commerce 2  
Paideia 6, Social Circle 0

### **Final**

Mt. Vernon 3, Paideia 1

## A, Div. 2 - BOYS

### **Round 1**

Dooly Co. 10, Montgomery Co. 0  
Lanier Co. 6, Wheeler County 1  
Mt. Zion-Carr. 6, Towns Co. 1  
Lincoln Co. 3, Bowdon 0

### **Round 1 Byes:**

Aquinas, McIntosh Co. Acad.,  
Atkinson Co., Lake Oconee Ac.,  
Wash.-Wilkes, Christian Her.,  
Echols Co., Macon Co., Portal,  
Chatahoochee Co., Fugees  
Academy and Ga. Military.

### **Round 2**

Aquinas 9, McIntosh Co. Acad. 0  
Atkinson Co. 4, Dooly Co. 2  
Lake Oconee Ac. 6, Lanier Co. 0  
Christian Her. 10, Wash.-Wilkes 0  
Mt. Zion-Carr. 5, Echols Co. 2  
Portal 5, Macon Co. 1  
Fugees Acad. 5, Chatt. Co. 1  
Ga. Military 9, Lincoln Co. 0

### **Quarterfinals**

Atkinson Co. 5, Aquinas 1  
Christian Her. 5, Lake Oconee Ac. 1  
Mt. Zion-Carr. 5, Portal 4  
Ga. Military 2, Fugees Acad. 0

### **Semifinals**

Christian Her. 3, Atkinson Co. 1  
Ga. Military 3, Mt. Zion-Carr. 0

### **Final**

Christian Her. 2, Ga. Military 1

## A, Div. 2 - GIRLS

### **Round 1**

Treutlen 1, Chatt. Co. 0  
Johnson Co. 3, Macon Co. 0  
Lincoln Co. 7, Bowdon 0  
Greene Co. 2, Christian Her 0  
Montgomery Co. 2, Lanier Co. 1  
Atkinson Co. 2, Wheeler Co. 0  
Ga. Military 10, Manchester 0

### **Round 1 Byes:**

Towns Co., Portal, Hawkinsville,  
Lake Oconee Acad., Atlanta  
Classical, Dooly Co., McIntosh  
Co. Academy, Mt. Zion-Carroll,  
and Aquinas

### **Round 2**

Towns Co. 7, Portal 3  
Hawkinsville 2, Treutlen 1  
Lake Oconee Ac. 2, Johnson Co. 0  
Atl. Classical 4, Lincoln Co. 2  
Dooly Co. 2, Greene Co. 1  
McIntosh Co. Ac. 4,  
Montgomery Co. 1  
Mt. Zion-Carr. 4, Atkinson Co. 3  
Aquinas 9, Ga. Military 0

### **Quarterfinals**

Towns Co. 2, Hawkinsville 0  
Lake Oconee Ac. 2, Atl. Classic. 1  
McIntosh Co. Ac. 4, Dooly Co. 0  
Aquinas 10, Mt. Zion-Carr. 0

### **Semifinals**

Towns Co. 1, Lake Oconee Ac. 0  
Aquinas 7, McIntosh Co. Ac. 0

### **Final**

Aquinas 5, Towns Co. 2

# STATE FASTPITCH SOFTBALL PLAYOFFS - 2022

**7A Super Regionals**

|                               |                       |
|-------------------------------|-----------------------|
| North Cobb.....5              | Denmark.....3         |
| North Gwinnett.....3          | Collins Hill.....0    |
| North Gwinnett.....4          | North Cobb.....2      |
| Denmark.....1                 | Collins Hill.....0    |
| Denmark.....5                 | North Cobb.....4      |
| <b>North Gwinnett</b> .....6  | Denmark.....0         |
| Hillgrove.....7               | Grayson.....2         |
| Colquitt County.....15        | Pebblebrook.....0     |
| Hillgrove.....6               | Colquitt County.....2 |
| Grayson.....16                | Pebblebrook.....1     |
| Colquitt County.....8         | Grayson.....0         |
| Colquitt County.....12        | Hillgrove.....3       |
| <b>Hillgrove</b> .....7       | Colquitt County.....3 |
| Lambert.....2                 | Cherokee.....0        |
| Buford.....13                 | Norcross.....0        |
| Lambert.....1                 | Buford.....0          |
| Cherokee.....9                | Norcross.....1        |
| Buford.....4                  | Cherokee.....0        |
| Buford.....6                  | Lambert.....4         |
| <b>Buford</b> .....4          | Lambert.....3         |
| Brookwood.....11              | Harrison.....6        |
| East Coweta.....8             | Camden County.....2   |
| East Coweta.....11            | Brookwood.....0       |
| Harrison.....8                | Camden County.....1   |
| Brookwood.....9               | Harrison.....5        |
| <b>East Coweta</b> .....5     | Brookwood.....4       |
| Campbell.....7                | Richmond Hill.....6   |
| North Paulding.....10         | Archer.....0          |
| North Paulding.....5          | Campbell.....1        |
| Archer.....14                 | Richmond Hill.....4   |
| Archer.....4                  | Campbell.....1        |
| <b>North Paulding</b> .....11 | Archer.....4          |
| Mill Creek.....2              | Duluth.....1          |
| Kennesaw Mtn.....3            | West Forsyth.....0    |
| Kennesaw Mtn.....2            | Mill Creek.....1      |
| West Forsyth.....7            | Duluth.....3          |
| Mill Creek.....8              | West Forsyth.....0    |
| <b>Kennesaw Mtn</b> .....3    | Mill Creek.....1      |
| Carrollton.....6              | Lowndes.....4         |
| Parkview.....11               | McEachern.....4       |
| Parkview.....10               | Carrollton.....2      |
| Lowndes.....11                | McEachern.....3       |
| Lowndes.....5                 | Carrollton.....2      |
| <b>Parkview</b> .....8        | Lowndes.....3         |
| Peachtree Ridge.....6         | Dacula.....5          |
| South Forsyth.....5           | Walton.....1          |
| South Forsyth.....7           | Peachtree Ridge.....3 |
| Dacula.....9                  | Walton.....7          |
| Dacula.....7                  | Peachtree Ridge.....3 |
| <b>South Forsyth</b> .....7   | Dacula.....2          |

**Elite Eight**

|                      |                      |
|----------------------|----------------------|
| North Gwinnett.....3 | North Paulding.....2 |
| Hillgrove.....2      | Kennesaw Mtn.....1   |
| Buford.....9         | Parkview.....1       |
| East Coweta.....6    | South Forsyth.....0  |
| North Gwinnett.....6 | Hillgrove.....1      |
| Buford.....2         | East Coweta.....1    |
| Buford.....3         | North Gwinnett.....1 |
| North Paulding.....3 | Kennesaw Mtn.....0   |
| South Forsyth.....1  | Parkview.....0       |
| East Coweta.....4    | North Paulding.....2 |
| South Forsyth.....3  | Hillgrove.....1      |
| East Coweta.....2    | South Forsyth.....0  |
| East Coweta.....3    | North Gwinnett.....2 |

**Final**

|              |                   |
|--------------|-------------------|
| Buford.....9 | East Coweta.....1 |
|--------------|-------------------|

**6A Super Regionals**

|                                 |                          |
|---------------------------------|--------------------------|
| Allatoona.....9                 | Newnan.....1             |
| Pope.....3                      | Jackson County.....1     |
| Pope.....6                      | Allatoona.....2          |
| Newnan.....11                   | Jackson County.....3     |
| Allatoona.....8                 | Newnan.....4             |
| <b>Pope</b> .....6              | Allatoona.....2          |
| Marist.....12                   | Rockdale County.....0    |
| Houston County.....12           | Evans.....0              |
| Houston County.....5            | Marist.....4             |
| Evans.....14                    | Rockdale County.....4    |
| Marist.....11                   | Evans.....3              |
| <b>Houston County</b> .....5    | Marist.....4             |
| Effingham County.....13         | Thomas Co. Central.....5 |
| Alcovy.....13                   | Riverwood.....5          |
| Effingham County.....5          | Alcovy.....4             |
| Riverwood.....14                | Thomas Co. Central.....7 |
| Alcovy.....8                    | Riverwood.....5          |
| <b>Effingham County</b> .....11 | Alcovy.....3             |
| North Forsyth.....10            | Blessed Trinity.....5    |
| River Ridge.....4               | East Paulding.....3      |
| River Ridge.....6               | North Forsyth.....1      |
| East Paulding.....8             | Blessed Trinity.....0    |
| East Paulding.....5             | North Forsyth.....4      |
| East Paulding.....10            | River Ridge.....7        |
| <b>River Ridge</b> .....10      | East Paulding.....5      |

|                               |                         |
|-------------------------------|-------------------------|
| South Paulding.....6          | Sequoyah.....2          |
| Apalachee.....12              | Sprayberry.....0        |
| Apalachee.....12              | South Paulding.....0    |
| Sequoyah.....6                | Sprayberry.....0        |
| Sequoyah.....4                | South Paulding.....2    |
| <b>Apalachee</b> .....6       | Sequoyah.....1          |
| Dunwoody.....6                | Woodward.....4          |
| South Effingham.....14        | Tift County.....0       |
| South Effingham.....15        | Dunwoody.....0          |
| Tift County.....9             | Woodward.....1          |
| Tift County.....14            | Dunwoody.....13         |
| <b>South Effingham</b> .....9 | Tift County.....0       |
| Veterans.....8                | Grovetown.....0         |
| North Atlanta.....20          | Jonesboro.....0         |
| Veterans.....10               | North Atlanta.....4     |
| Grovetown.....20              | Jonesboro.....2         |
| Grovetown.....6               | North Atlanta.....4     |
| <b>Veterans</b> .....8        | Grovetown.....0         |
| Lassiter.....8                | Habersham Central.....0 |
| Creekview.....5               | Alexander.....1         |
| Lassiter.....5                | Creekview.....3         |
| Alexander.....12              | Habersham Central.....9 |
| Creekview.....9               | Alexander.....1         |
| <b>Lassiter</b> .....3        | Creekview.....1         |

**Elite Eight**

|                        |                        |
|------------------------|------------------------|
| Pope.....8             | Effingham County.....0 |
| River Ridge.....8      | Houston County.....0   |
| Apalachee.....5        | Veterans.....2         |
| Lassiter.....3         | South Effingham.....4  |
| Pope.....4             | River Ridge.....2      |
| Apalachee.....6        | Lassiter.....4         |
| Pope.....4             | Apalachee.....0        |
| Effingham County.....7 | Houston County.....6   |
| South Effingham.....4  | Veterans.....0         |
| Lassiter.....6         | Effingham County.....0 |
| River Ridge.....5      | South Effingham.....0  |
| Lassiter.....4         | River Ridge.....1      |
| Apalachee.....1        | Lassiter.....0         |

**Final**

|            |                 |
|------------|-----------------|
| Pope.....6 | Apalachee.....3 |
|------------|-----------------|

**5A Super Regionals**

|                             |                       |
|-----------------------------|-----------------------|
| Kell.....13                 | Lithia Springs.....1  |
| Eastside.....12             | Cartersville.....0    |
| Eastside.....4              | Kell.....1            |
| Cartersville.....12         | Lithia Springs.....0  |
| Kell.....3                  | Cartersville.....1    |
| Kell.....11                 | Eastside.....9        |
| <b>Eastside</b> .....8      | Kell.....3            |
| Northgate.....12            | Decatur.....2         |
| Locust Grove.....21         | Greenbrier.....17     |
| Northgate.....10            | Locust Grove.....2    |
| Greenbrier.....3            | Decatur.....0         |
| Greenbrier.....11           | Locust Grove.....2    |
| Greenbrier.....8            | Northgate.....0       |
| <b>Northgate</b> .....8     | Greenbrier.....0      |
| Ola.....9                   | Statesboro.....1      |
| Harris County.....16        | Tucker.....0          |
| Harris County.....6         | Ola.....0             |
| Statesboro.....17           | Tucker.....1          |
| Ola.....12                  | Statesboro.....7      |
| <b>Harris County</b> .....4 | Ola.....3             |
| Winder-Barrow.....6         | Woodland-Bartow.....2 |
| Villa Rica.....12           | North Springs.....0   |
| Villa Rica.....6            | Winder-Barrow.....5   |
| Woodland-Bartow.....4       | North Springs.....0   |
| Woodland-Bartow.....14      | Winder-Barrow.....5   |
| <b>Villa Rica</b> .....13   | Woodland-Bartow.....4 |
| Chattahoochee.....7         | Chapel Hill.....2     |
| Loganville.....13           | Cass.....1            |
| Loganville.....12           | Chattahoochee.....0   |
| Cass.....10                 | Chapel Hill.....1     |
| Chattahoochee.....10        | Cass.....7            |
| <b>Loganville</b> .....13   | Chattahoochee.....5   |
| Northside-Col.....13        | Arabia Mountain.....1 |
| Coffee.....8                | Jones County.....7    |
| Northside-Col.....9         | Coffee.....1          |
| Jones County.....8          | Arabia Mountain.....0 |
| Jones County.....14         | Coffee.....0          |
| <b>Northside-Col</b> .....5 | Jones County.....0    |
| Union Grove.....18          | Ware County.....8     |
| Chamblee.....10             | McIntosh.....2        |
| Chamblee.....9              | Union Grove.....1     |
| McIntosh.....14             | Ware County.....2     |
| McIntosh.....8              | Union Grove.....2     |
| <b>Chamblee</b> .....9      | McIntosh.....1        |
| Flowers Branch.....5        | Calhoun.....3         |
| Cambridge.....15            | Creekside.....0       |
| Cambridge.....1             | Flowers Branch.....0  |
| Cahoun.....13               | Creekside.....1       |
| Flowers Branch.....2        | Calhoun.....0         |
| Flowers Branch.....4        | Cambridge.....2       |
| <b>Cambridge</b> .....8     | Flowers Branch.....3  |

**Elite Eight**

|                     |                |
|---------------------|----------------|
| Harris County.....1 | Eastside.....0 |
|---------------------|----------------|

|                      |                     |
|----------------------|---------------------|
| Northgate.....2      | Villa Rica.....1    |
| Loganville.....5     | Chamblee.....2      |
| Northside-Col.....8  | Cambridge.....0     |
| Harris County.....2  | Northgate.....0     |
| Northside-Col.....8  | Loganville.....4    |
| Northside-Col.....13 | Harris County.....0 |
| Eastside.....2       | Villa Rica.....1    |
| Cambridge.....8      | Chamblee.....0      |
| Loganville.....11    | Eastside.....1      |
| Northgate.....3      | Cambridge.....2     |
| Loganville.....11    | Northgate.....3     |
| Loganville.....4     | Harris County.....3 |

**Final**

|                     |                  |
|---------------------|------------------|
| Northside-Col.....4 | Loganville.....0 |
|---------------------|------------------|

**4A Super Regionals**

|                                |                         |
|--------------------------------|-------------------------|
| Hampton.....10                 | Holy Innocents'.....2   |
| Central-Carroll.....9          | Cherokee Bluff.....0    |
| Central-Carroll.....8          | Hampton.....0           |
| Cherokee Bluff.....14          | Holy Innocents'.....1   |
| Cherokee Bluff.....9           | Hampton.....3           |
| <b>Central-Carroll</b> .....6  | Cherokee Bluff.....3    |
| LaGrange.....7                 | Islands.....0           |
| Cairo.....8                    | Griffin.....0           |
| Cairo.....4                    | LaGrange.....3          |
| Islands.....8                  | LaGrange.....4          |
| Islands.....7                  | Cairo.....3             |
| <b>Islands</b> .....13         | Cairo.....7             |
| Perry.....20                   | Westover.....2          |
| Wayne County.....6             | Troup.....3             |
| Wayne County.....9             | Perry.....5             |
| Troup.....8                    | Westover.....0          |
| Troup.....1                    | Perry.....0             |
| <b>Wayne County</b> .....10    | Troup.....4             |
| East Forsyth.....9             | NW Whitfield.....2      |
| Pace Academy.....15            | Miller Grove.....0      |
| East Forsyth.....13            | Pace Academy.....0      |
| NW Whitfield.....15            | Miller Grove.....2      |
| NW Whitfield.....16            | Pace Academy.....6      |
| NW Whitfield.....9             | East Forsyth.....7      |
| <b>East Forsyth</b> .....9     | NW Whitfield.....3      |
| Lovett.....12                  | SW DeKalb.....0         |
| Walnut Grove.....10            | Sonoraville.....2       |
| Walnut Grove.....6             | Lovett.....0            |
| Sonoraville.....19             | SW DeKalb.....3         |
| Lovett.....3                   | Sonoraville.....1       |
| <b>Walnut Grove</b> .....8     | Lovett.....0            |
| Trinity Christian.....14       | SE Bulloch.....6        |
| West Laurens.....17            | Shaw.....0              |
| West Laurens.....6             | Trinity Christian.....0 |
| SE Bulloch.....11              | Shaw.....3              |
| Trinity Christian.....10       | SE Bulloch.....7        |
| <b>West Laurens</b> .....8     | Trinity Christian.....0 |
| Bainbridge.....8               | Howard.....2            |
| Whitewater.....15              | Burke County.....0      |
| Whitewater.....15              | Bainbridge.....0        |
| Burke County.....10            | Howard.....7            |
| Bainbridge.....9               | Burke County.....2      |
| <b>Whitewater</b> .....3       | Bainbridge.....2        |
| Heritage-Catoosa.....8         | North Oconee.....1      |
| Westminster.....6              | Stockbridge.....5       |
| Heritage-Catoosa.....15        | Westminster.....0       |
| North Oconee.....12            | Stockbridge.....3       |
| North Oconee.....15            | Westminster.....0       |
| <b>Heritage-Catoosa</b> .....4 | North Oconee.....1      |

**Elite Eight**

|                       |                        |
|-----------------------|------------------------|
| Central-Carroll.....7 | Wayne County.....3     |
| East Forsyth.....2    | Islands.....0          |
| Walnut Grove.....2    | Whitewater.....1       |
| West Laurens.....2    | Heritage-Catoosa.....1 |
| Central-Carroll.....6 | East Forsyth.....0     |
| West Laurens.....6    | Walnut Grove.....5     |
| West Laurens.....2    | Central-Carroll.....1  |
| Islands.....5         | Wayne County.....3     |
| Whitewater.....8      | Heritage-Catoosa.....0 |
| Islands.....2         | Walnut Grove.....1     |
| Whitewater.....8      | East Forsyth.....0     |
| Whitewater.....9      | Islands.....0          |
| Whitewater.....3      | Central-Carroll.....0  |

**Final**

|                      |                    |
|----------------------|--------------------|
| West Laurens.....1-2 | Whitewater.....2-1 |
|----------------------|--------------------|

**3A Super Regionals**

|                        |                       |
|------------------------|-----------------------|
| LaFayette.....25       | Cedar Grove.....0     |
| Wesleyan.....7         | Franklin County.....1 |
| Wesleyan.....4         | LaFayette.....0       |
| Franklin County.....24 | Cedar Grove.....0     |
| LaFayette.....9        | Franklin County.....0 |
| <b>Wesleyan</b> .....7 | LaFayette.....0       |
| Morgan County.....10   | Calvary Day.....0     |
| Crisp County.....7     | Upson-Lee.....3       |
| Crisp County.....5     | Morgan County.....3   |
| Upson-Lee.....17       | Calvary Day.....4     |
| Morgan County.....16   | Upson-Lee.....1       |

# STATE FASTPITCH SOFTBALL PLAYOFFS - 2022

|                              |                          |
|------------------------------|--------------------------|
| <b>Crisp County</b> .....6   | Morgan County.....0      |
| Jackson.....5                | Thomasville.....0        |
| Long County.....23           | Hephzibah.....0          |
| Jackson.....4                | Long County.....0        |
| Thomasville.....15           | Hephzibah.....0          |
| Long County.....11           | Thomasville.....3        |
| <b>Jackson</b> .....9        | Long County.....0        |
| White County.....18          | Oconee County.....6      |
| Ringgold.....17              | Sandy Creek.....5        |
| White County.....7           | Ringgold.....6           |
| Oconee County.....14         | Sandy Creek.....2        |
| Oconee County.....10         | Ringgold.....2           |
| Oconee County.....9          | White County.....6       |
| <b>Oconee County</b> .....12 | White County.....2       |
| Bremen.....16                | Carver-Atlanta.....0     |
| Monroe Area.....9            | Lumpkin County.....0     |
| Bremen.....4                 | Monroe Area.....1        |
| Lumpkin County.....19        | Carver-Atlanta.....0     |
| Monroe Area.....14           | Lumpkin County.....6     |
| Monroe Area.....5            | Bremen.....3             |
| <b>Bremen</b> .....2         | Monroe Area.....1        |
| Savannah Christian.....16    | Cross Creek.....0        |
| Pike County.....20           | Dougherty.....0          |
| Pike County.....9            | Savannah Christian.....0 |
| Cross Creek.....12           | Dougherty.....8          |
| Savannah Christian.....14    | Cross Creek.....2        |
| <b>Pike County</b> .....17   | Savannah Christian.....2 |
| Columbus.....8               | Mary Persons.....7       |
| Harlem.....9                 | St. Vincents.....0       |
| Harlem.....9                 | Columbus.....1           |
| Mary Persons.....11          | St. Vincents.....2       |
| Columbus.....5               | Mary Persons.....4       |
| <b>Harlem</b> .....5         | Columbus.....1           |
| Hebron Christian.....2       | Pickens.....1            |
| Gordon Lee.....16            | Douglass-Atlanta.....1   |
| Gordon Lee.....8             | Hebron Christian.....0   |
| Pickens.....16               | Douglass-Atlanta.....0   |
| Pickens.....9                | Hebron Christian.....8   |
| <b>Gordon Lee</b> .....10    | Pickens.....2            |
| <b>Elite Eight</b>           |                          |
| Wesleyan.....5               | Jackson.....2            |
| Oconee County.....6          | Crisp County.....2       |
| Bremen.....4                 | Harlem.....3             |
| Gordon Lee.....6             | Pike County.....5        |
| Wesleyan.....10              | Oconee County.....0      |
| Gordon Lee.....15            | Bremen.....6             |
| Wesleyan.....9               | Gordon Lee.....0         |
| Jackson.....7                | Crisp County.....0       |
| Harlem.....4                 | Pike County.....1        |
| Jackson.....8                | Bremen.....7             |
| Harlem.....7                 | Oconee County.....0      |
| Jackson.....5                | Harlem.....4             |
| Jackson.....7                | Gordon Lee.....2         |
| <b>Final</b>                 |                          |
| Wesleyan.....3               | Jackson.....1            |

|                              |                            |
|------------------------------|----------------------------|
| <b>2A</b>                    |                            |
| <b>Super Regionals</b>       |                            |
| North Cobb Christian.....10  | Landmark Christian.....1   |
| Rockmart.....19              | East Jackson.....0         |
| Rockmart.....12              | North Cobb Christian.....0 |
| Landmark Christian.....19    | East Jackson.....4         |
| North Cobb Christian.....4   | Landmark Christian.....3   |
| <b>Rockmart</b> .....17      | North Cobb Christian.....0 |
| Vidalia.....16               | Washington County.....0    |
| Jeff Davis.....16            | Central Macon.....1        |
| Jeff Davis.....1             | Vidalia.....0              |
| Washington County.....17     | Central Macon.....9        |
| Vidalia.....16               | Washington County.....0    |
| <b>Jeff Davis</b> .....9     | Vidalia.....0              |
| Berrien.....18               | Rutland.....1              |
| Appling County.....13        | Josey.....1                |
| Appling County.....3         | Berrien.....1              |
| Rutland.....16               | Josey.....4                |
| Berrien.....11               | Rutland.....6              |
| <b>Appling County</b> .....6 | Berrien.....1              |
| Banks County.....10          | North Murray.....2         |
| ELCA.....17                  | Washington.....0           |
| ELCA.....2                   | Banks County.....1         |
| North Murray.....17          | Washington.....2           |
| Banks County.....10          | North Murray.....3         |
| <b>ELCA</b> .....7           | Banks County.....0         |
| Callaway.....17              | Walker.....1               |
| Union County.....6           | Murray County.....5        |
| Union County.....12          | Callaway.....2             |
| Murray County.....11         | Walker.....1               |
| Murray County.....12         | Callaway.....8             |
| <b>Union County</b> .....10  | Murray County.....8        |
| Brantley County.....15       | Putnam County.....0        |
| ACE Charter.....12           | Cook.....0                 |
| ACE Charter.....7            | Brantley County.....6      |
| Cook.....19                  | Putnam County.....1        |
| Cook.....11                  | Brantley County.....1      |
| <b>ACE Charter</b> .....8    | Cook.....0                 |
| Dodge County.....17          | Northeast Macon.....0      |

|                             |                            |
|-----------------------------|----------------------------|
| Pierce County.....8         | Thomson.....3              |
| Pierce County.....8         | Dodge County.....2         |
| Thomson.....20              | Northeast Macon.....1      |
| Dodge County.....4          | Thomson.....2              |
| <b>Pierce County</b> .....5 | Dodge County.....4         |
| Haralson County.....14      | Providence Christian.....6 |
| Mt. Paran.....18            | Columbia.....0             |
| Mt. Paran.....10            | Haralson County.....7      |
| Providence Christian.....23 | Columbia.....5             |
| Haralson County.....8       | Providence Christian.....7 |
| <b>Mt. Paran</b> .....10    | Haralson County.....7      |
| <b>Elite Eight</b>          |                            |
| Appling County.....8        | Rockmart.....0             |
| Jeff Davis.....3            | ELCA.....2                 |
| Pierce County.....7         | Union County.....2         |
| Mt. Paran.....8             | ACE Charter.....0          |
| Jeff Davis.....5            | Appling County.....0       |
| Mt. Paran.....2             | Pierce County.....1        |
| Jeff Davis.....2            | Mt. Paran.....0            |
| Rockmart.....7              | ELCA.....5                 |
| ACE Charter.....5           | Union County.....0         |
| Pierce County.....7         | Rockmart.....4             |
| ACE Charter.....3           | Appling County.....2       |
| ACE Charter.....3           | Pierce County.....2        |
| Mt. Paran.....7             | ACE Charter.....6          |
| <b>Final</b>                |                            |
| Jeff Davis.....4            | Mt. Paran.....2            |

|                               |                          |
|-------------------------------|--------------------------|
| <b>A, Division 1</b>          |                          |
| <b>Super Regionals</b>        |                          |
| Oglethorpe County.....6       | Mt. Pisgah.....5         |
| Pepperell.....15              | Athens Christian.....0   |
| Pepperell.....5               | Oglethorpe County.....0  |
| Mt. Pisgah.....15             | Athens Christian.....0   |
| Mt. Pisgah.....7              | Oglethorpe County.....5  |
| <b>Pepperell</b> .....9       | Mt. Pisgah.....1         |
| Crawford County.....8         | Metter.....4             |
| Bacon County.....12           | Jefferson County.....5   |
| Bacon County.....6            | Crawford County.....5    |
| Metter.....12                 | Jefferson County.....0   |
| Crawford County.....3         | Metter.....0             |
| <b>Bacon County</b> .....9    | Crawford County.....5    |
| Swainsboro.....15             | Pelham.....0             |
| Bryan County.....8            | Temple.....0             |
| Bryan County.....8            | Swainsboro.....1         |
| Temple.....12                 | Pelham.....2             |
| Temple.....8                  | Swainsboro.....0         |
| <b>Bryan County</b> .....5    | Temple.....1             |
| Commerce.....4                | Trion.....2              |
| Prince Avenue.....17          | King's Ridge.....0       |
| Prince Avenue.....12          | Commerce.....4           |
| Trion.....17                  | King's Ridge.....0       |
| Trion.....8                   | Commerce.....2           |
| <b>Prince Avenue</b> .....10  | Trion.....2              |
| Social Circle.....12          | Whitefield Academy.....0 |
| Elbert County.....4           | Chattooga.....3          |
| Social Circle.....8           | Elbert County.....5      |
| Chattooga.....9               | Whitefield Academy.....6 |
| Elbert County.....10          | Chattooga.....4          |
| <b>Social Circle</b> .....7   | Elbert County.....4      |
| Lamar County.....7            | Screven County.....6     |
| Bleckley County.....15        | Brooks County.....0      |
| Bleckley County.....8         | Lamar County.....0       |
| Screven County.....15         | Brooks County.....0      |
| Lamar County.....11           | Screven County.....7     |
| <b>Bleckley County</b> .....6 | Lamar County.....0       |
| Irwin County.....8            | East Laurens.....6       |
| Heard County.....7            | Claxton.....0            |
| Heard County.....10           | Irwin County.....0       |
| East Laurens.....8            | Claxton.....0            |
| East Laurens.....9            | Irwin County.....0       |
| <b>Heard County</b> .....10   | East Laurens.....0       |
| Dade County.....15            | Rabun County.....0       |
| Mt. Vernon.....16             | Jasper County.....0      |
| Mt. Vernon.....5              | Dade County.....3        |
| Rabun County.....16           | Jasper County.....6      |
| Dade County.....8             | Rabun County.....5       |
| Dade County.....6             | Mt. Vernon.....3         |
| <b>Mt. Vernon</b> .....9      | Dade County.....2        |
| <b>Elite Eight</b>            |                          |
| Pepperell.....4               | Bryan County.....0       |
| Bacon County.....6            | Prince Avenue.....2      |
| Heard County.....8            | Social Circle.....1      |
| Mt. Vernon.....1              | Bleckley County.....0    |
| Pepperell.....8               | Bacon County.....1       |
| Heard County.....5            | Mt. Vernon.....1         |
| Heard County.....9            | Pepperell.....1          |
| Prince Avenue.....3           | Bryan County.....2       |
| Social Circle.....4           | Bleckley County.....0    |
| Prince Avenue.....14          | Mt. Vernon.....1         |
| Social Circle.....7           | Bacon County.....2       |
| Social Circle.....3           | Prince Avenue.....2      |
| Social Circle.....3           | Pepperell.....2          |
| <b>Final</b>                  |                          |
| Heard County.....3            | Social Circle.....2      |

|                                      |                             |
|--------------------------------------|-----------------------------|
| <b>A, Division 2</b>                 |                             |
| <b>Super Regionals</b>               |                             |
| Marion County.....9                  | Johnson County.....1        |
| Bowdon.....15                        | Townsend County.....0       |
| Bowdon.....1                         | Marion County.....0         |
| Johnson County.....12                | Townsend County.....4       |
| Marion County.....5                  | Johnson County.....2        |
| <b>Bowdon</b> .....8                 | Marion County.....1         |
| Hawkinsville.....9                   | Montgomery County.....4     |
| Baconton.....16                      | Echols County.....1         |
| Hawkinsville.....16                  | Baconton.....14             |
| Echols County.....6                  | Montgomery County.....5     |
| Baconton.....14                      | Echols County.....6         |
| <b>Hawkinsville</b> .....13          | Baconton.....5              |
| Charlton County.....9                | Seminole County.....0       |
| Emanuel Co. Institute.....11         | Wheeler County.....3        |
| Emanuel Co. Institute.....8          | Charlton County.....0       |
| Wheeler County.....14                | Seminole County.....3       |
| Charlton County.....11               | Wheeler County.....3        |
| <b>Emanuel Co. Institute</b> .....11 | Charlton County.....0       |
| Washington-Wilkes.....12             | Washington Heritage.....1   |
| Glascoek County.....9                | Manchester.....0            |
| Glascoek County.....6                | Washington-Wilkes.....3     |
| Manchester.....17                    | Christian Heritage.....1    |
| Washington-Wilkes.....6              | Manchester.....2            |
| <b>Glascoek County</b> .....2        | Washington-Wilkes.....0     |
| Georgia Military.....3               | Taylor County.....0         |
| Lake Oconee Acad.....                | by                          |
| Georgia Military.....6               | Lake Oconee Acad.....0      |
| Lake Oconee Acad.....5               | Taylor County.....0         |
| <b>Georgia Military</b> .....5       | Lake Oconee Acad.....1      |
| Portal.....6                         | Telfair County.....1        |
| Lanier County.....17                 | Miller County.....2         |
| Portal.....5                         | Lanier County.....4         |
| Telfair County.....10                | Miller County.....2         |
| Lanier County.....17                 | Telfair County.....4        |
| Lanier County.....7                  | Portal.....5                |
| <b>Lanier County</b> .....17         | Portal.....2                |
| Clinch County.....6                  | Pataula Charter.....3       |
| Wilcox County.....13                 | Jenkins County.....0        |
| Wilcox County.....12                 | Clinch County.....0         |
| Pataula Charter.....16               | Jenkins County.....12       |
| Pataula Charter.....15               | Clinch County.....11        |
| <b>Wilcox County</b> .....11         | Pataula Charter.....0       |
| Lincoln County.....16                | Mt. Zion.....13             |
| Schley County.....17                 | Wilkinson County.....1      |
| Schley County.....14                 | Lincoln County.....0        |
| Mt. Zion.....16                      | Wilkinson County.....3      |
| Lincoln County.....13                | Mt. Zion.....11             |
| <b>Schley County</b> .....13         | Lincoln County.....1        |
| <b>Elite Eight</b>                   |                             |
| Emanuel Co. Institute.....5          | Bowdon.....0                |
| Hawkinsville.....1                   | Glascoek County.....0       |
| Georgia Military.....6               | Wilcox County.....2         |
| Lanier County.....5                  | Schley County.....4         |
| Emanuel Co. Institute.....4          | Hawkinsville.....0          |
| Lanier County.....5                  | Georgia Military.....2      |
| Lanier County.....3                  | Emanuel Co. Institute.....2 |
| Glascoek County.....10               | Bowdon.....2                |
| Wilcox County.....13                 | Schley County.....4         |
| Georgia Military.....6               | Glascoek County.....2       |
| Wilcox County.....3                  | Hawkinsville.....0          |
| Georgia Military.....4               | Wilcox County.....1         |
| Emanuel Co. Institute.....7          | Georgia Military.....2      |
| <b>Final</b>                         |                             |
| Emanuel Co. Institute 1-4            | Lanier County.....0-0       |

# SLOW PITCH PLAYOFFS - 2023

|                         |                       |
|-------------------------|-----------------------|
| <b>Round 1</b>          |                       |
| Haralson County.....9   | Oconee County.....4   |
| Franklin County.....11  | Jefferson.....1       |
| West Laurens.....4      | Sequoyah.....1        |
| Dodge County.....8      | Creekview.....5       |
| <b>Winner's Bracket</b> |                       |
| Haralson County.....9   | Franklin County.....8 |
| West Laurens.....2      | Dodge County.....0    |
| West Laurens.....14     | Haralson County.....8 |
| <b>Loser's Bracket</b>  |                       |
| Jefferson.....15        | Oconee County.....4   |
| Sequoyah.....11         | Creekview.....7       |
| Jefferson.....4         | Dodge County.....3    |
| Sequoyah.....10         | Franklin County.....4 |
| Sequoyah.....13         | Jefferson.....5       |
| Haralson County.....17  | Sequoyah.....8        |
| <b>Final</b>            |                       |
| West Laurens.....9      | Haralson County.....8 |

# STATE SWIMMING MEET - 2023

## Class 7A Boys

### **200 Yard Medley Relay**

1. N. GWINNETT 1:32.82 (Burnley, Blake; Joo, Avery; Reinhold, Logan; DenBrok, Tristan)
2. BROOKWOOD 1:33.29 (Stanton, William; Inlow, Max; Heffner, Tyler; Patterson, Nolan)
3. LAMBERT 1:34.16 (Sayer, Nathan; Saylor, Noah; Johnson, Ford; Kim, Youngjae)
4. PARKVIEW 1:34.32 (Dunbar, Jack; Hart, Russell; Xu, Jeffery; Plumlee, Landon)

### **200 Yard Freestyle**

1. DenBrok, Tristan N. GWINNETT 1:37.48
2. McClain, Mitch HARRISON 1:38.58
3. Rariden, Nathan HILLGROVE 1:39.80
4. Heffner, Tyler BROOKWOOD 1:39.81

### **200 Yard IM**

1. Stanton, William BROOKWOOD 1:46.52
2. Long, Liam WALTON 1:52.28
3. Saylor, Noah LAMBERT 1:52.72
4. Anderson, Cade W. FORSYTH 1:52.80

### **50 Yard Freestyle**

1. Patterson, Nolan BROOKWOOD 20.64
2. Case, Ryan DENMARK 21.02
3. Franks, Jesse WALTON 21.19
4. Schnupp, Andrew ARCHER 21.50

### **1 Meter Diving**

1. Bridges, Bo COLQUITT CO. 853.50
2. Gregory, Tuck COLQUITT CO. 721.70
3. Hoard, Tyler WALTON 699.25
4. Gregory, Trip COLQUITT CO. 675.70

### **100 Yard Butterfly**

1. Irwin, Benjamin BUFORD 46.94#
2. Burnley, Blake N. GWINNETT 49.52
3. Malone, Matthew S. FORSYTH 50.09
4. Ware, David KENNESAW MTN. 51.03

### **100 Yard Freestyle**

1. McClain, Mitch HARRISON 45.37
2. Dunbar, Jack PARKVIEW 45.66
3. Rariden, Nathan HILLGROVE 45.68
4. Patterson, Nolan BROOKWOOD 46.02

### **500 Yard Freestyle**

1. DenBrok, Tristan N. GWINNETT 4:20.75
2. Heffner, Tyler BROOKWOOD 4:24.22
3. Cushing, Daniel WALTON 4:33.20
4. Burnley, Blake N. GWINNETT 4:37.66

### **200 Yard Freestyle Relay**

1. PARKVIEW 1:25.04 (Dunbar, Jack; Hart, Russell; Beene, Nikolas; Plumlee, Landon)
2. DENMARK 1:25.59 (Goshko, Daniel; Bakunin, Vlad; Cresap, Brandon; Case, Ryan)
3. WALTON 1:25.76 (Franks, Jesse; Lovett, Griffin; Iglar, William; Thomas, Theodore)
4. LAMBERT 1:26.54 (Saylor, Noah; Sayer, Nathan; Johnson, Ford; Kim, Youngjae)

### **100 Yard Backstroke**

1. Irwin, Benjamin BUFORD 46.91
2. Stanton, William BROOKWOOD 48.18
3. Dunbar, Jack PARKVIEW 50.43
4. Long, Liam WALTON 51.40

### **100 Yard Breaststroke**

1. Hart, Russell PARKVIEW 56.67
2. Saylor, Noah LAMBERT 57.17
3. Henry, Derek S. FORSYTH 57.20
4. Johnson, Ford LAMBERT 57.91

### **400 Yard Freestyle Relay**

1. N. GWINNETT 3:03.49 (Burnley, Blake; Wilson, Eli; Han, Nathan; DenBrok, Tristan)
2. BROOKWOOD 3:03.88 (Patterson, Nolan; Heffner, Tyler; Wright, Harrison; Stanton, William)
3. WALTON 3:09.15 (Thomas, Theodore; Cushing, Daniel; Panessa, John; Long, Liam)
4. DENMARK 3:09.95 (Goshko, Daniel; Bakunin, Vlad; Case, Ryan; Cresap, Brandon)

## **Team Scores**

1. Walton .....414.0
2. North Gwinnett .....406.0
3. Brookwood .....345.0
4. Parkview .....245.0

## Class 7A Girls

### **200 Yard Medley Relay**

1. N. GWINNETT 1:44.99 (Morton, Ashley; Jenny, Morgan; Thompson, Jayla; Reiser, Emma)
2. LAMBERT 1:46.15 (Thomas, Brielle; Zaleski, Ally; Jones, Ella; West, Kara)
3. BROOKWOOD 1:46.80 (Dopson, Hailey; Britt, Hayden; Weitzel, Mary Kate; Amike, Nicole)
4. WHEELER 1:48.93 (Young, Ansley; Fannin, Mattie; Garrett, Mackenzie; Hawkins, Reese)

### **200 Yard Freestyle**

1. Klinefelter, Isabella HARRISON 1:48.25
2. Jones, Ella LAMBERT 1:48.44
3. Reiser, Emma N. GWINNETT 1:48.75
4. Tiller, Jamison N. GWINNETT 1:52.75

### **200 Yard IM**

1. Choate, Catie NORCROSS 2:01.39
2. Starnes, Sydney WALTON 2:04.52
3. Jenny, Morgan N. GWINNETT 2:04.57
4. Zaleski, Ally LAMBERT 2:05.60

### **50 Yard Freestyle**

1. West, Kara LAMBERT 22.87
2. Gilson, Natalie DENMARK 23.22
3. Thompson, Jayla N. GWINNETT 23.96
4. Ochoa, Iris MILL CREEK 24.41

### **1 Meter Diving**

1. McCranie, Ruth Anne COLQUITT CO. 626.00
2. Icard, Shannon COLQUITT CO. 573.75
3. Brothers, Chloe BROOKWOOD 570.60
4. Cummo, Michelle W. FORSYTH 558.85

### **100 Yard Butterfly**

1. Klinefelter, Isabella HARRISON 54.81
2. Thompson, Jayla N. GWINNETT 55.51
3. Rothwell, Vivien MILL CREEK 55.72
4. Jones, Ella LAMBERT 56.89

### **100 Yard Freestyle**

1. Gilson, Natalie DENMARK 50.42
2. West, Kara LAMBERT 50.55
3. Dopson, Hailey BROOKWOOD 51.61
4. Tiller, Jamison N. GWINNETT 52.38

### **500 Yard Freestyle**

1. Reiser, Emma N. GWINNETT 4:51.27
2. Starnes, Sydney WALTON 4:54.27
3. Jenny, McKenzie N. GWINNETT 4:58.96
4. Thompson, Charlotte MTN. VIEW 4:59.78

### **200 Yard Freestyle Relay**

1. N. GWINNETT 1:36.49 (Morton, Ashley; Jenny, Morgan; Tiller, Jamison; Thompson, Jayla)
2. LAMBERT 1:36.91 (Zaleski, Ally; Wallace, Mia; Jones, Ella; West, Kara)
3. BROOKWOOD 1:37.14 (Amike, Nicole; Greene, Emma; Hamilton, Sophie; Dopson, Hailey)
4. HARRISON 1:38.39 (Knight, Hannah; Wright, Kayla; Rice, Addie; Klinefelter, Isabella)

## **100 Yard Backstroke**

1. Choate, Catie NORCROSS 53.36
2. Dopson, Hailey BROOKWOOD 54.37
3. Morton, Ashley N. GWINNETT 55.81
4. Scharff, Caroline FORSYTH CENT. 56.04

## **100 Yard Breaststroke**

1. Jezerinac, Evelyn KENNESAW MTN. 1:02.27
2. Zaleski, Ally LAMBERT 1:04.31
3. Jenny, Morgan N. GWINNETT 1:04.73
4. Luskus, Sarah W. FORSYTH 1:05.97

## **400 Yard Freestyle Relay**

1. WALTON 3:32.52 (Starnes, Sydney; Jansons, Karina; Osborn, Lily; Alderman, Lily)
2. HARRISON 3:32.88 (Knight, Hannah; Wright, Kayla; Rice, Addie; Klinefelter, Isabella)
3. N. GWINNETT 3:34.84 (Jenny, McKenzie; Bock, Jordan; Tiller, Jamison; Reiser, Emma)
4. FORSYTH CENT. 3:36.68 (Scharff, Caroline; Koman, Payton; Alexander, Avi; Cesario, Anna)

## **Team Scores**

1. North Gwinnett .....429.5
2. Brookwood .....374.0
3. Lambert .....285.5
4. Walton .....249.5

## Class 6A Boys

### **200 Yard Medley Relay**

1. JOHNS CREEK 1:35.01 (Bao, Daniel; Spann, Britton; Perez, Nathan; Cerniglia, Matthew)
2. ALLATOONA 1:35.15 (Bried, Gustavo; Hanesworth, Landon; Smith, Noah; Baer, Bennett)
3. MARIST 1:35.97 (Wiegand, Alexander; Kleinrock, David; Phillips, Grogan; Tharp, Jack)
4. DUNWOODY 1:36.73 (Amerson, Luke; Tutt, Cameron; Waasdorp, Lucas; Sandberg, Luke)

### **200 Yard Freestyle**

1. Sandberg, Luke DUNWOODY 1:40.61
2. Burch, Hudson LAKESIDE-EVANS 1:41.53
3. Medley, Nathan ROME 1:42.11
4. Plantamura, Nicholas LAKESIDE-EV. 1:43.32

### **200 Yard IM**

1. Amerson, Luke DUNWOODY 1:53.84
2. Martenson, Cannon MARIST 1:54.85
3. Hill, Ben EVANS 1:59.21
4. Peterson, Bryce POPE 1:59.25

### **50 Yard Freestyle**

1. Smith, Noah ALLATOONA 20.68
2. Sharabura, Eric N. ATLANTA 21.05
3. Steinhauer, Craig LAKESIDE-DEK. 21.16
4. Yount, Colby MARIST 21.37

### **1 Meter Diving**

1. Loftin, Carter LASSITER 675.70
2. Snyder, RJ WOODWARD 655.35
3. Gummere, Ryland ST. PIUS 529.75
4. Tharp, Will MARIST 507.60

### **100 Yard Butterfly**

1. Kjaerulff, Nicholas CREEKVIEW 48.74
2. Medley, Nathan ROME 50.06
3. Bao, Daniel JOHNS CREEK 50.84
4. Sutter, Zach ST. PIUS 51.19

### **100 Yard Freestyle**

1. Smith, Noah ALLATOONA 45.47
2. Perez, Nathan JOHNS CREEK 46.36
3. Sharabura, Eric N. ATLANTA 46.38
4. Sandberg, Luke DUNWOODY 46.49

### **500 Yard Freestyle**

1. Spann, Britton JOHNS CREEK 4:35.55
2. Baer, Bennett ALLATOONA 4:38.78

# STATE SWIMMING MEET - 2023

3. Browne, Aiden JOHNS CREEK 4:42.59
4. Gray, Matthew BLESSED TRINITY 4:42.71

## 200 Yard Freestyle Relay

1. MARIST 1:26.45 (Clarkson, Eli; Yount, Colby; Martenson, Cannon; Tharp, Jack)
2. LAKESIDE-DEK. 1:26.68 (Peterson, Elijah; Crawford, Indiana; Collins, Ethan; Steinhauer, Craig)
3. ALPHARETTA 1:27.45 (Bai, Edward; Clarke, Aidan; Hinton, John; Xiao, Thomas)
4. LASSITER 1:28.69 (Elmore, Elliot; Wilson, Patrick; O'Brien, Aidan; Tanke, Parker)

## 100 Yard Backstroke

1. Kjaerulff, Nicholas CREEKVIEW 50.13
2. Amerson, Luke DUNWOODY 51.15
3. Wiegand, Alexander MARIST 51.82
4. Bried, Gustavo ALLATOONA 52.07

## 100 Yard Breaststroke

1. Spann, Britton JOHNS CREEK 56.06
2. Xiao, Thomas ALPHARETTA 56.24
3. Elmore, Elliot LASSITER 59.29
4. Kleinrock, David MARIST 1:00.33

## 400 Yard Freestyle Relay

1. JOHNS CREEK 3:11.06 (Bao, Daniel; Lou, Alexander; Spann, Britton; Perez, Nathan)
- \*2. ALLATOONA 3:12.35 (Baer, Bennett; Bried, Gustavo; Hanesworth, Landon; Smith, Noah)
- \*2. MARIST 3:12.35 (Phillips, Grogan; Yount, Colby; Wiegand, Alexander; Martenson, Cannon)
4. LAKESIDE-EVANS 3:12.36 (Plantamura, Nicholas; Burch, Hudson; Blanchard, William; Price, Trevor)

## Team Scores

|                      |       |
|----------------------|-------|
| 1. Johns Creek ..... | 368.5 |
| 2. Marist .....      | 342.0 |
| 3. St. Pius .....    | 249.0 |
| 4. Lassiter .....    | 233.0 |

## Class 6A Girls

### 200 Yard Medley Relay

1. LASSITER 1:44.01 (Jollands, Finny; O'Shaughnessy, Maggie; Parker, Sophia; Jones, Rose)
2. LAKESIDE-DEK. 1:46.80 (Webb, Ansley; Richards, Lyla; McClintock, Katelyn; Hook, Sophia)
3. MARIST 1:49.01 (Jacob, Abby; Donkar, Allie; Akumabor, Angel; Scruggs, Maeve)
4. POPE 1:51.44 (Owen, Caroline; Sears, Lillian; Armstrong, Kate; Balyo, Sophie)

### 200 Yard Freestyle

1. Blase, Laurel SEQUOYAH 1:48.77
2. Jones, Rose LASSITER 1:50.49
3. Murphy, Brooke JOHNS CREEK 1:50.87
4. Bradley, Kate LASSITER 1:53.09

### 200 Yard IM

1. Tilt, Elizabeth LASSITER 2:01.32
2. O'Shaughnessy, Maggie LASSITER 2:06.55
3. Richards, Lyla LAKESIDE-DEK. 2:06.87
4. Donkar, Allie MARIST 2:09.62

### 50 Yard Freestyle

1. Hook, Sophia 16 LAKESIDE-DEK. 23.64
2. Jollands, Finny LASSITER 23.66
3. Hinton, Lauren ALPHARETTA 23.74
4. Northrop, Juliann 16 POPE 24.22

### 1 Meter Diving

1. Herring, Julia ST. PIUS 655.60
2. Debowsky, Ayla JOHNS CREEK 532.90
3. Rivas, Amelia MARIST 237.90
4. Zafft, Prielle LANIER 210.10

### 100 Yard Butterfly

1. Tilt, Elizabeth LASSITER 53.83
2. Murphy, Brooke JOHNS CREEK 55.77
3. Parker, Sophia LASSITER 56.15
4. McClintock, Katelyn LAKESIDE-DEK. 56.84

### 100 Yard Freestyle

1. Hinton, Lauren ALPHARETTA 51.61
2. Case, Ashley WOODSTOCK 52.29
3. Hook, Sophia LAKESIDE-DEK. 52.41
4. Jacob, Abby MARIST 53.35

### 500 Yard Freestyle

1. Blase, Laurel SEQUOYAH 4:58.06
2. Jones, Rose LASSITER 5:02.84
3. Benton, Reese DUNWOODY 5:03.99
4. Kjaerulff, Victoria CREEKVIEW 5:08.93

### 200 Yard Freestyle Relay

1. LASSITER 1:37.01 (Tilt, Elizabeth; Shaw, Morgan; Bradley, Kate; Parker, Sophia)
2. POPE 1:39.19 (Slorahn, Piper; Balyo, Sophie; Tsynman, Katherine; Northrop, Juliann)
3. ALPHARETTA 1:39.89 (Murphy, Addison; Modglin, Sydney; Richard, Hailey; Hinton, Lauren)
4. MARIST 1:40.75 (Copenhaver, Elizabeth Ann; Schaffer, Caroline; Akumabor, Angel; Scruggs, Maeve)

### 100 Yard Backstroke

1. Jollands, Finny LASSITER 56.80
2. Bradley, Kate LASSITER 58.43
3. Medina, Astrid ETOWAH 58.50
4. Robinson, Kennsingtyn RIVERWOOD 59.37

### 100 Yard Breaststroke

1. Donkar, Allie MARIST 1:03.32
2. O'Shaughnessy, Maggie LASSITER 1:03.97
3. Richards, Lyla LAKESIDE-DEK. 1:05.01
4. Benton, Reese DUNWOODY 1:05.46

### 400 Yard Freestyle Relay

1. LASSITER 3:27.52 (Jones, Rose; Jollands, Finny; Bradley, Kate; Tilt, Elizabeth)
2. LAKESIDE-DEK. 3:33.87 (McClintock, Katelyn; Baldwin, Anna; Richards, Lyla; Hook, Sophia)
3. MARIST 3:35.32 (Schaffer, Caroline; Jacob, Abby; Donkar, Allie; Copenhaver, Elizabeth Ann)
4. POPE 3:36.53 (Slorahn, Piper; Owen, Caroline; Tsynman, Katherine; Northrop, Juliann)

### Team Scores

|                          |       |
|--------------------------|-------|
| 1. Lassiter .....        | 486.0 |
| 2. Marist .....          | 314.0 |
| 3. Pope .....            | 286.0 |
| 4. Lakeside-DeKalb ..... | 261.0 |

## Class 4-5A Boys

### 200 Yard Medley Relay

1. CENTENNIAL 1:36.78 (Paek, Caleb; Osborne, Graham; Aplin, Maerk; Gricus, Maximilian)
2. CHATTAHOOCHEE 1:36.80 (Choi, Eddie; Calhoun, Logan; Slater, Landon; Gonzalez, Daniel)
3. CHAMBLEE 1:36.81 (Combs, Ian; Bolte, Jack; Harper, Dayon; McLellan, Jack)
4. NORTHVIEW 1:36.96 (Tan, Ashton; Liu, Andrew; Mo, JunYi (Kevin); Gavin, William)

### 200 Yard Freestyle

1. Roden, Leo N. SPRINGS 1:38.00
2. King, Madison LOVETT 1:42.62
3. Combs, Ian CHAMBLEE 1:42.93
4. Hudson, Grant MCINTOSH 1:43.54

### 200 Yard IM

1. Freudenstein, Carter PACE ACAD. 1:51.48
2. Christman, Walter N. SPRINGS 1:54.76
3. Gonzalez, Daniel CHATTAHOOCHEE 1:56.01
4. Tan, Ashton NORTHVIEW 1:56.78

### 50 Yard Freestyle

1. Wall, Dean CHEROKEE BLUFF 20.54
2. Gavin, William NORTHVIEW 20.73
3. Bleuez, Andrew MCINTOSH 21.22
4. Davis, Kyle JEFFERSON 21.49

### 1 Meter Diving

1. Sadler, Aiden NORTH OCONEE 788.35
2. Lyman, Thomas MIDTOWN 711.90

3. Weinstein, Samuel GREENBRIER 544.95
4. Rourk, Jack CHAMBLEE 465.60

### 100 Yard Butterfly

1. Freudenstein, Carter PACE ACAD. 49.48
2. Bleuez, Andrew MCINTOSH 50.73
3. Xiao, James CEDAR SHOALS 51.07
4. Cahill, Caden BENEDICTINE 51.40

### 100 Yard Freestyle

1. Roden, Leo N. SPRINGS 44.79
2. Gavin, William NORTHVIEW 45.53
3. King, Madison LOVETT 46.86
4. Hudson, Grant MCINTOSH 47.44

### 500 Yard Freestyle

1. Calhoun, Logan CHATTAHOOCHEE 4:39.63
2. Slater, Landon CHATTAHOOCHEE 4:40.99
3. Roach, Braeden STARR'S MILL 4:42.15
4. Koch, Christopher CEDAR SHOALS 4:42.41

### 200 Yard Freestyle Relay

1. PACE ACAD. 1:27.42 (Freudenstein, Carter; Canova, Lane; Hight, Barrett; Richardson, Reid)
2. LOVETT 1:28.92 (Hall, Alex; Cauwenberghs, Alec; Fornaserio, Christopher; King, Madison)
3. DECATUR 1:29.24 (Lewis, Isaiah; Franklin, Aiden; Lewis, Cloud; Robertson, Owen)
4. CHEROKEE BLUFF 1:29.49 (Young, Evan; Nelson, Pace; Wall, Maxwell; Wall, Dean)

### 100 Yard Backstroke

1. Choi, Eddie CHATTAHOOCHEE 51.06
2. Combs, Ian CHAMBLEE 51.87
3. Cahill, Caden BENE 52.21
4. Gricus, Maximilian CENTENNIAL 52.49

### 100 Yard Breaststroke

1. Osborne, Graham CENTENNIAL 57.45
2. Christman, Walter N. SPRINGS 58.13
3. Dibkey, Ethan BENEDICTINE 58.41
4. Stanley, Luke GACS 58.57

### 400 Yard Freestyle Relay

1. CHATTAHOOCHEE 3:11.06 (Choi, Eddie; Slater, Landon; Calhoun, Logan; Gonzalez, Daniel)
2. NORTHVIEW 3:11.45 (Tan, Ashton; Liu, Ethan; Mo, JunYi (Kevin); Gavin, William)
3. CHAMBLEE 3:17.13 (Johnson, Sam; Harper, Dayon; Combs, Ian; McLellan, Jack)
4. PACE ACAD. 3:18.41 (Freudenstein, Carter; Canova, Lane; Hight, Barrett; Richardson, Reid)

### Team Scores

|                        |       |
|------------------------|-------|
| 1. Chattahoochee ..... | 282.0 |
| 2. Chamblee .....      | 233.5 |
| 3. Northview .....     | 218.0 |
| 4. Pace Academy .....  | 192.0 |

## Class 4-5A Girls

### 200 Yard Medley Relay

1. GACS 1:45.61 (Bennett, Ainsley; Parker, Caroline; House, Madeline; Heizer, Abigail)
2. CAMBRIDGE 1:46.54 (Brisson, Sophie; Gaines, Caroline; Kerber, Kate; Griner, Jennifer)
3. WESTMINSTER 1:47.14 (Clayton, Sadie; Horst, Janine; Horst, Genae; Sgross, Ansley)
4. CHAMBLEE 1:47.40 (Smith, Lilly; Entrekin, Evelyn; Murphy, Madeline; Alexandrova, Mena)

### 200 Yard Freestyle

1. Brisson, Sophie CAMBRIDGE 1:48.15
2. Ketron, Sara WESTMINSTER 1:52.41
3. Halbach, Ansley N. OCONEE 1:53.41
4. Griner, Jennifer CAMBRIDGE 1:54.65

### 200 Yard IM

1. Zboran, Abby LOGANVILLE 2:01.37
2. Entrekin, Evelyn CHAMBLEE 2:05.51
3. Kasik, Allison CENTENNIAL 2:08.21
4. Kerber, Kate CAMBRIDGE 2:08.68

### 50 Yard Freestyle

1. Heizer, Abigail GACS 23.40
2. Horst, Genae WESTMINSTER 23.91

# STATE SWIMMING MEET - 2023

3. Clayton, Sadie WESTMINSTER 24.48
4. Prevost, Sarah MDTW 24.86

## 1 Meter Diving

1. Buckley, Ivy N. OCONEE 678.65#
2. Drudge, Rin N. OCONEE 569.30
3. Petit, Brooklyn CAMBRIDGE 555.55
4. Irwin, Alexandra WESTMINSTER 510.00

## 100 Yard Butterfly

1. Christopherson, Katie WESTMINSTER 52.77
2. Zboran, Abby LOGANVILLE 55.07
3. Lillie, Lila MCINTOSH 56.02
4. Stewart, Olivia STATESBORO 56.55

## 100 Yard Freestyle

1. Richardson, Jory MIDTOWN 50.88
2. Heizer, Abigail GACS 51.49
3. Dalton, Alexis LOVETT 52.38
4. Smith, Lilly CHAMBLEE 53.03

## 500 Yard Freestyle

1. Ketron, Sara WESTMINSTER 5:02.84
2. Halbach, Ansley N. OCONEE 5:04.40
3. Bennett, Ainsley GACS 5:04.82
4. House, Madeline GACS 5:10.25

## 200 Yard Freestyle Relay

1. WESTMINSTER 1:34.19 (Christopherson, Katie; Horst, Genae; Ketron, Sara; Horst, Janine)
2. JEFFERSON 1:40.39 (Young, Ximena; Alewine-Flores, Aubree-Clare; Nunnally, Ansley; Dunagan, Katherine)
3. LOGANVILLE 1:40.50 (Endicott, Blair; Warden, Haley; Ryan, Kyleigh; Zboran, Abby)
4. NORTHVIEW 1:40.76 (Crowley, Sasara; Yu, Grace; Zhou, Amelia; Tong, Lillian)

## 100 Yard Backstroke

1. Brison, Sophie CAMBRIDGE 53.62
2. Lillie, Lila MCINTOSH 55.45
3. Richardson, Jory MIDTOWN 55.70
4. Clayton, Sadie WESTMINSTER 57.66

## 100 Yard Breaststroke

1. Christopherson, Katie WESTMINSTER 1:00.81
2. Entrekin, Evelyn CHAMBLEE 1:01.01
3. Stewart, Olivia STATESBORO 1:01.95
4. Dalton, Alexis LOVETT 1:03.65

## 400 Yard Freestyle Relay

1. WESTMINSTER 3:30.02 (Christopherson, Katie; Sgroso, Ansley; Clayton, Sadie; Ketron, Sara)
2. GACS 3:33.17 (Heizer, Abigail; Todebush, Rachel; Bennett, Ainsley; House, Madeline)
3. CAMBRIDGE 3:33.31 (Kerber, Kate; Gaines, Caroline; Griner, Jennifer; Brison, Sophie)
4. NORTHVIEW 3:39.28 (Zhou, Amelia; Crowley, Sasara; Tong, Lillian; Turcotte, Olivia)

## Team Scores

|                      |       |
|----------------------|-------|
| 1. Westminster ..... | 428.0 |
| 2. Cambridge .....   | 349.0 |
| 3. GACS .....        | 280.0 |
| 4. Chamblee .....    | 248.0 |

## Class 1-3A Boys

### 200 Yard Medley Relay

1. PROVIDENCE 1:39.89 (Mallory, Noah; Krakoviak, Luke; Curtis, Riley; Van Soelen, Addison)
2. N. COBB CHRIST. 1:40.45 (Carden, Michael; Pool, Grant; Clark, Andrew; Hamilton, Garrett)
3. ATHENS ACAD. 1:40.85 (Kennedy, Garrett; Phillips, Luke; Hines, Will; Dillon, Robbie)
4. WHITEFIELD ACAD. 1:41.28 (Brooks, Jackson; Marrero, Kye; Zwygart, Stanton; Mansfield, Whitacre)

### 200 Yard Freestyle

1. Casey, Simon OCONEE CO. 1:38.66
2. Grand'Pierre, Raphael WALKER 1:41.81
3. Cummings, Jac COLUMBUS 1:44.78
4. Brooks, Jackson WHITEFIELD AC. 1:45.64

## 200 Yard IM

1. Payne, Robert ATLANTA INTER. 1:58.95
2. Tolbert, Wade PAIDEIA 1:59.32
3. Skedsvold, Collin AQUINAS 2:03.50
4. Marrero, Kye WHITEFIELD ACAD. 2:03.80

## 50 Yard Freestyle

1. Kruep, Rylan MT. VERNON 20.54
2. Perry, Max WESLEYAN 21.40
3. Danforth, Jason GALLOWAY 21.86
4. Mallory, Noah PROVIDENCE 21.94

## 1 Meter Diving

1. Tinney, Jake THOMASVILLE 496.00
2. Crutchfield, Aidan SOCIAL CIRCLE 412.75
3. Fuentes, Greg MT. VERNON 193.35

## 100 Yard Butterfly

1. Grand'Pierre, Raphael WALKER 50.42
2. Carden, Michael N. COBB CHRIST. 50.48
3. Hines, Will ATHENS ACADEMY 52.80
4. Gasper, Matthew HEBRON CHRIST. 53.04

## 100 Yard Freestyle

1. Casey, Simon OCONEE COUNTY 44.83
2. Kruep, Rylan MT. VERNON 46.36
3. Van Soelen, Addison PROVIDENCE 47.80
4. McCarthy, Liam PAIDEIA 48.47

## 500 Yard Freestyle

1. Brooks, Jackson WHITEFIELD AC. 4:48.50
2. Clark, Andrew N. COBB CHRIST. 4:51.07
3. Stephens, Jonathan MT. PISGAH 4:54.99
4. Harmon, William SAV. CTY. DAY 5:11.50

## 200 Yard Freestyle Relay

1. WESLEYAN 1:29.33 (Homan, Ray; Weidle, Paul; Wasmuth, Henry; Perry, Max)
2. PAIDEIA 1:32.10 (Hamrick, Nat; Tolbert, Wade; Campbell, Liam; McCarthy, Liam)
3. ADAIRSVILLE 1:32.86 (Brown, Cooper; Greenway, Gabriel; Barnett, Andy; Rizer, Brayden)
4. COLUMBUS 1:33.37 (Albright, Jacob; Bunt, David; Witzke, Lawrence; Cummings, Jac)

## 100 Yard Backstroke

1. Kennedy, Garrett ATHENS ACAD. 51.21
2. Carden, Michael N. COBB CHRIST. 51.34
3. Danforth, Jason GALLOWAY 52.76
4. Cummings, Jac COLUMBUS 52.92

## 100 Yard Breaststroke

1. McCarthy, Liam PAIDEIA 1:01.86
2. Leal, Tyler JOHNSON-AUG. 1:02.21
3. Brown, Cooper ADAIRSVILLE 1:02.33
4. Marrero, Kye WHITEFIELD ACAD. 1:02.45

## Yard Freestyle Relay

1. WESLEYAN 3:17.65 (Neeb, JJ; Homan, Ray; Wasmuth, Henry; Perry, Max)
2. PROVIDENCE 3:19.76 (Van Soelen, Addison; Curtis, Riley; Krakoviak, Luke; Mallory, Noah)
3. N. COBB CHRIST. 3:20.68 (Hamilton, Garrett; Clark, Andrew; Pool, Grant; Carden, Michael)
4. WHITEFIELD ACAD. 3:21.88 (Zwygart, Stanton; Mansfield, Whitacre; Marrero, Kye; Brooks, Jackson)

## Team Scores

|                               |       |
|-------------------------------|-------|
| 1. Wesleyan .....             | 252.0 |
| 2. Whitefield Academy.....    | 235.0 |
| 3. North Cobb Christian ..... | 203.0 |
| 4. Providence Christian ..... | 193.0 |

## Class 1-3A Girls

### 200 Yard Medley Relay

1. ST. VINCENTS 1:50.08 (Nelson, Avery; Nelson, Ella; Baraniak, Camryn; Helton, Lilly)
2. WHITEFIELD AC. 1:57.22 (Vonderahe, Annie; Estep, Riess; Harris, Claire; Marrero, Ari)
3. COLUMBUS 1:57.99 (Sanders, Savannah; Barna, Yena; Kelley, Lucy; Miller, Michaela)

4. WESLEYAN 1:59.62 (Woods, Mary Margaret; Stewart, Caroline; Friedman, Lindsay; Harrison, Mary Caroline)

## 200 Yard Freestyle

1. Livezey, Emma MT. PISGAH 1:52.88
2. Cummins, Campbell Grace MT. PISGAH 1:55.33
3. Lichty, Phoebe LANDMARK 2:02.34
4. Hosier, Vivian WESLEYAN 2:03.35

## 200 Yard IM

1. Wasmuth, Hattie WESLEYAN 2:06.33
2. Dampier, Madison TALLULAH FALLS 2:08.54
3. Estep, Riess WHITEFIELD ACAD. 2:10.94
4. Nelson, Avery ST. VINCENTS 2:12.44

## 50 Yard Freestyle

1. McKallip, Maela MARY PERSONS 23.92
2. Miller, Michaela COLUMBUS 23.99
3. Baraniak, Camryn ST. VINCENTS 24.72
4. Marrero, Ari WHITEFIELD ACAD. 25.25

## 1 Meter Diving

1. Stamps, Caroline OCONEE CO. 617.75
2. Suits, Abby WESLEYAN 584.00
3. Baker, Kinsley MT. VERNON 556.45
4. Beaty, Reagan WESLEYAN 437.15

## 100 Yard Butterfly

1. Dampier, Madison TALLULAH FALLS 56.68
2. Ward, Katie PIKE COUNTY 56.83
3. Cappola, Chloe MVP 1:00.24
4. Cummins, Campbell Grace MT. PISGAH 1:00.25

## 100 Yard Freestyle

1. Livezey, Emma MT. PISGAH 51.74
2. McKallip, Maela MARY PERSONS 52.26
3. Miller, Michaela COLUMBUS 52.65
4. Park, Yenna SAV. CTY. DAY 53.19

## 500 Yard Freestyle

1. Wasmuth, Hattie WESLEYAN 5:10.93
2. McLaughlin, Ella ST. VINCENTS 5:40.35

## 200 Yard Freestyle Relay

1. ST. VINCENTS 1:40.17 (Nelson, Avery; Nelson, Ella; Helton, Lilly; Baraniak, Camryn)
2. MT. PISGAH 1:40.71 (Cummins, Campbell Grace; Crutchfield, Ansley; Raley, Sarah Beth; Livezey, Emma)
3. WESLEYAN 1:41.82 (Hosier, Vivian; Friedman, Lindsay; Harrison, Mary Caroline; Wasmuth, Hattie)
4. COLUMBUS 1:44.47 (Barna, Yena; Sanders, Savannah; Kelley, Lucy; Miller, Michaela)

## 100 Yard Backstroke

1. Ward, Katie PIKE COUNTY 57.12
2. Cappola, Chloe MT. VERNON 1:00.04
3. Norris, Claire RICHMOND ACAD. 1:00.08
4. Nelson, Avery ST. VINCENTS 1:00.75

## 100 Yard Breaststroke

1. Estep, Riess WHITEFIELD ACAD. 1:06.20
2. Park, Yenna SAV. CTY. DAY 1:06.39
3. Nelson, Ella ST. VINCENTS 1:07.06
4. Lichty, Phoebe LANDMARK 1:10.70

## 400 Yard Freestyle Relay

1. WESLEYAN 3:45.27 (Hosier, Vivian; Chapman, Ansley; Stewart, Caroline; Wasmuth, Hattie)
2. MT. PISGAH 3:45.54 (Cummins, Campbell Grace; Crutchfield, Ansley; Raley, Sarah Beth; Livezey, Emma)
3. MARY PERSONS 3:46.99 (Atkinson, Campbell; Stembbridge, Abbey; Wood, Alanna; McKallip, Maela)
4. WHITEFIELD AC. 3:51.49 (Vonderahe, Annie; Browne, Catherine; Estep, Riess; Marrero, Ari)

## Team Scores

|                               |       |
|-------------------------------|-------|
| 1. Wesleyan .....             | 300.0 |
| 2. St. Vincents Academy.....  | 282.0 |
| 3. Whitefield Academy .....   | 215.0 |
| 4. Mt. Pisgah Christian ..... | 172.0 |

## # - State Record

# STATE TENNIS PLAYOFFS - 2023

## 7A - BOYS

### Round 1

West Forsyth 3, Cherokee 0  
Norcross 3, Collins Hill 0  
Parkview 3, Marietta 2  
Camden County 4, Westlake 0  
Milton 3, Wheeler 1  
Mill Creek 3, Duluth 0  
North Paulding 3, Grayson 1  
Campbell 3, Colquitt County 0  
Richmond Hill 3, Carrollton 2  
Harrison 3, Archer 0  
Peachtree Ridge 3, Buford 1  
South Forsyth 3, Walton 0  
Valdosta 5, East Coweta 0  
Brookwood 3, Hillgrove 0  
North Gwinnett 3, Dacula 0  
Lambert 3, Kennesaw Mtn. 0

### Round 2

West Forsyth 3, Norcross 1  
Camden County 3, Parkview 2  
Milton 3, Mill Creek 2  
Campbell 3, North Paulding 0  
Harrison 3, Richmond Hill 0  
South Forsyth 3, Peachtree Ridge 0  
Brookwood 3, Valdosta 0  
Lambert 3, North Gwinnett 0

### Quarterfinals

West Forsyth 3, Camden County 0  
Milton 3, Campbell 1  
South Forsyth 3, Harrison 2  
Lambert 3, Brookwood 0

### Semifinals

West Forsyth 3, Milton 1  
Lambert 3, South Forsyth 0

### Final

Lambert 3, West Forsyth 0

## 7A - GIRLS

### Round 1

Lambert 3, Wheeler 0  
North Gwinnett 3, Mtn. View 0  
Parkview 3, North Paulding 0  
Valdosta 5, East Coweta 0  
South Forsyth 3, Kennesaw Mtn. 0  
Mill Creek 3, Peachtree Ridge 0  
Marietta 3, Grayson 0  
Colquitt County 3, Carrollton 2  
Lowndes 3, Campbell 2  
Hillgrove 3, Archer 0  
Duluth 3, Buford 1  
Walton 3, Milton 0  
Camden County 4, Westlake 1  
Brookwood 3, Harrison 0  
Norcross 3, Collins Hill 0  
West Forsyth 3, North Cobb 0

### Round 2

North Gwinnett 3, Lambert 2  
Valdosta 3, Parkview 0  
South Forsyth 3, Mill Creek 0  
Marietta 3, Colquitt County 0  
Hillgrove 3, Lowndes 1  
Walton 3, Duluth 0  
Brookwood 3, Camden County 1  
West Forsyth 3, Norcross 1

### Quarterfinals

North Gwinnett 3, Valdosta 0  
South Forsyth 3, Marietta 0

Walton 3, Hillgrove 0  
West Forsyth 3, Brookwood 0

### Semifinals

North Gwinnett 3, South Forsyth 0  
Walton 3, West Forsyth 0

### Final

Walton 3, North Gwinnett 1

## 6A - BOYS

### Round 1

Sequoyah 3, Paulding County 0  
Johns Creek 3, North Forsyth 0  
St. Pius X 5, Morrow 0  
Tift County 3, Grovetown 0  
Woodstock 3, Alexander 0  
Alpharetta 3, Gainesville 0  
North Atlanta 3, Rockdale County 0  
Glynn Academy 3, Veterans 0  
Lakeside-Evans 5, Lee County 0  
Lakeside-DeKalb 3, Woodward 2  
Blessed Trinity 5, Habersham Cent. 0  
Newnan 3, Etowah 1  
Effingham County 3, Houston County 0  
Marist 3, Forest Park 0  
Pope 3, Jackson County 0  
Allatoona 3, Douglas County 0

### Round 2

Johns Creek 5, Sequoyah 0  
St. Pius X 5, Tift County 0  
Alpharetta 3, Woodstock 0  
North Atlanta 4, Glynn Academy 1  
Lakeside-DeKalb 3, Lakeside-Evans 0  
Blessed Trinity 3, Newnan 0  
Marist 3, Effingham County 0  
Pope 3, Allatoona 0

### Quarterfinals

Johns Creek 3, St. Pius X 0  
North Atlanta 3, Alpharetta 1  
Blessed Trinity 3, Lakeside-DeKalb 1  
Marist 3, Pope 2

### Semifinals

Johns Creek 3, North Atlanta 1  
Marist 3, Blessed Trinity 1

### Final

Johns Creek 3, Marist 0

## 6A - GIRLS

### Round 1

River Ridge 5, Newnan 0  
Alpharetta 3, Lanier 0  
St. Pius X 1, Lovejoy 0  
Lee County 3, South Effingham 0  
Creekview 3, Douglas County 1  
Lassiter 3, Gainesville 0  
Lakeside-DeKalb 3, Rockdale County 0  
Lakeside-Evans 4, Houston County 0  
Glynn Academy 3, Veterans 2  
Woodward Acad. 3, Dunwoody 2  
Roswell 3, Jackson County 0  
Woodstock 3, South Paulding 0  
Effingham County 3, Tift County 2  
Marist 3, Forest Park 0  
Johns Creek 3, Habersham Central 0  
Rome 3, Alexander 0

### Round 2

Alpharetta 3, River Ridge 0  
St. Pius X 5, Lee County 0  
Lassiter 3, Creekview 2

Lakeside-Evans 3, Lakeside-DeKalb 0  
Woodward Academy 4, Glynn Academy 0  
Roswell 3, Woodstock 0  
Marist 4, Effingham County 0  
Johns Creek 3, Rome 0

### Quarterfinals

Alpharetta 3, St. Pius X 0  
Lakeside-Evans 3, Lassiter 0  
Roswell 3, Woodward Academy 1  
Marist 4, Johns Creek 0

### Semifinals

Alpharetta 3, Lakeside-Evans 1  
Marist 3, Roswell 0

### Final

Marist 3, Alpharetta 0

## 5A - BOYS

### Round 1

Chattahoochee 4, Jackson-Atlanta 0  
Cartersville 3, Clarke Central 0  
Chamblee 3, Northside-Columbus 0  
Statesboro 5, Ola 0  
Cambridge 3, Chapel Hill 0  
Woodland-Bartow 3, Jefferson 2  
Northgate 3, Tucker 0  
Union Grove 3, Ware County 0  
Coffee 3, Dutchtown 0  
McIntosh 5, Arabia Mountain 0  
Dalton 3, Flowers Branch 2  
Centennial 3, Midtown 2  
Greenbrier 3, Jones County 1  
Decatur 3, Harris County 0  
Calhoun 3, Loganville 0  
GACS 4, Villa Rica 0

### Round 2

Chattahoochee 4, Cartersville 0  
Statesboro 3, Chamblee 0  
Cambridge 3, Woodland-Bartow 0  
Union Grove 3, Northgate 1  
McIntosh 4, Coffee 1  
Centennial 3, Dalton 0  
Decatur 3, Greenbrier 0  
GACS 5, Calhoun 0

### Quarterfinals

Chattahoochee 3, Statesboro 0  
Cambridge 3, Union Grove 0  
McIntosh 3, Centennial 2  
GACS 3, Decatur 0

### Semifinals

Chattahoochee 3, Cambridge 1  
GACS 5, McIntosh 0

### Final

GACS 3, Chattahoochee 0

## 5A - GIRLS

### Round 1

Cambridge 3, Chapel Hill 0  
Calhoun 3, Winder-Barrow 0  
Decatur 4, Harris County 0  
Statesboro 4, Eagles Landing 0  
Northview 5, Villa Rica 0  
Loganville 3, Cass 0  
McIntosh 4, Tucker 0  
Greenbrier 3, Union Grove 0  
Ware County 3, Ola 2  
Northgate 3, Arabia Mountain 0  
Jefferson 3, Cartersville 1  
Chattahoochee 3, Midtown 1

# STATE TENNIS PLAYOFFS - 2023

Coffee 4, Jones County 0  
Chamblee 3, Northside-Columbus 0  
Dalton 3, Flowery Branch 2  
Centennial 3, Lithia Springs 0

## Round 2

Cambridge 3, Calhoun 0  
Decatur 3, Statesboro 2  
Northview 3, Loganville 0  
Greenbrier 3, McIntosh 0  
Ware County 3, Northgate 2  
Chattahoochee 4, Jefferson 0  
Chamblee 3, Coffee 0  
Centennial 3, Dalton 0

## Quarterfinals

Cambridge 3, Decatur 2  
Northview 3, Greenbrier 0  
Chattahoochee 3, Ware County 0  
Centennial 3, Chamblee 0

## Semifinals

Northview 3, Cambridge 2  
Chattahoochee 3, Centennial 2

## Final

Northview 3, Chattahoochee 2

## 4A - BOYS

### Round 1

Holy Innocents' 5, Hampton 0  
Sonorville 3, North Hall 0  
LaGrange 4, SE Bulloch 1  
Bainbridge 5, Baldwin 0  
Lovett 4, Druid Hills 0  
North Oconee 5, Heritage-Catoosa 0  
Islands 4, Whitewater 1  
West Laurens 5, Hardaway 0  
Perry 3, Westover 2  
Benedictine 5, Troup 0  
Cherokee Bluff 3, Central-Carroll 1  
Pace Academy 5, SW DeKalb 0  
Cairo 4, Spalding 1  
Starr's Mill 3, Wayne County 0  
Madison County 3, Cedartown 1  
Westminster 5, McDonough 0

### Round 2

Holy Innocents' 3, Sonorville 0  
LaGrange 3, Bainbridge 0  
North Oconee 3, Lovett 2  
West Laurens 3, Islands 1  
Benedictine 5, Perry 0  
Pace Academy 3, Cherokee Bluff 0  
Starr's Mill 3, Cairo 0  
Westminster 5, Madison County 0

## Quarterfinals

Holy Innocents' 3, LaGrange 0  
North Oconee 5, West Laurens 0  
Pace Academy 3, Benedictine 0  
Westminster 3, Starr's Mill 0

## Semifinals

North Oconee 3, Holy Innocents' 0  
Westminster 3, Pace Academy 0

## Final

Westminster 3, North Oconee 0

## 4A - GIRLS

### Round 1

Holy Innocents' 5, Luella 0  
Central-Carroll 3, Madison County 1  
Starr's Mill 3, Islands 0  
Bainbridge 4, Howard 0

Lovett 4, Druid Hills 0  
North Hall 3, Heritage-Cat. 0  
Whitewater 3, Wayne County 2  
West Laurens 5, Hardaway 0  
Spalding 4, Westover 1  
SE Bulloch 5, Trinity Christian 0  
North Oconee 5, Cedartown 0  
Pace Academy 3, Miller Grove 0  
Cairo 4, Perry 1  
LaGrange 5, Burke County 0  
Cherokee Bluff 3, Sonorville 0  
Westminster 5, Hampton 0

## Round 2

Holy Innocents' 3, Central-Carroll 1  
Bainbridge 3, Starr's Mill 1  
North Hall 3, Lovett 2  
West Laurens 3, Whitewater 0  
SE Bulloch 5, Spalding 0  
Pace Academy 3, North Oconee 1  
LaGrange 4, Cairo 0  
Westminster 3, Cherokee Bluff 0

## Quarterfinals

Holy Innocents' 3, Bainbridge 0  
North Hall 3, West Laurens 0  
Pace Academy 4, SE Bulloch 0  
Westminster 3, LaGrange 0

## Semifinals

North Hall 3, Holy Innocents' 2  
Pace Academy 3, Westminster 2

## Final

Pace Academy 3, North Hall 0

## 3A - BOYS

### Round 1

Ringgold 5, Cedar Grove 0  
Wesleyan 3, Stephens County 0  
Richmond Acad. 3, Calvary Day 2  
Columbus 5, Jackson 0  
Coahulla Creek 5, Douglass-Atlanta 0  
Oconee County 5, Pickens 0  
Savannah Christian 5, Harlem 0  
Mary Persons 5, Dougherty 0  
Upson-Lee 3, Monroe 2  
Sav. Country Day 5, Hephzibah 0  
Hebron Christian 3, Dawson County 1  
Adairsville 3, Sandy Creek 1  
Thomasville 4, Pike County 0  
Morgan County, Bye  
Lumpkin County 3, Franklin County 1  
Bremen, Bye

### Round 2

Wesleyan 5, Ringgold 0  
Columbus 5, Richmond Academy 0  
Oconee County 4, Coahulla Creek 0  
Savannah Christian 3, Mary Persons 0  
Sav. Country Day 5, Upson-Lee 0  
Hebron Christian 3, Adairsville 0  
Morgan County 5, Thomasville 0  
Lumpkin County 3, Bremen 0

## Quarterfinals

Wesleyan 3, Columbus 1  
Oconee County 3, Savannah Christian 0  
Sav. Country Day 3, Hebron Christian 2  
Lumpkin County 3, Morgan County 2

## Semifinals

Wesleyan 3, Oconee County 0  
Sav. Country Day 3, Lumpkin County 2

## Final

Wesleyan 3, Sav. Country Day 0

## 3A - GIRLS

### Round 1

Coahulla Creek 5, Douglass-Atlanta 0  
Wesleyan 5, Franklin County 0  
Savannah Christian 5, Richmond Acad. 0  
Columbus 5, Jackson 0  
Ringgold 3, Carver-Atlanta 0  
Oconee County 5, Gilmer 0  
St. Vincents 3, Harlem 0  
Mary Persons 3, Monroe 0  
Thomasville 3, Upson-Lee 0  
Sav. Country Day 5, Cross Creek 0  
Hebron Christian 3, Lumpkin County 1  
LaFayette 3, Sandy Creek 0  
Crisp County 3, Pike County 2  
Morgan County 3, Calvary Day 2  
Dawson County 3, Stephens County 2  
Bremen 5, Cedar Grove 0

### Round 2

Wesleyan 4, Coahulla Creek 0  
Columbus 5, Savannah Christian 0  
Oconee County 4, Ringgold 0  
St. Vincents 3, Mary Persons 0  
Sav. Country Day 3, Thomasville 0  
Hebron Christian 5, LaFayette 0  
Morgan County 3, Crisp County 0  
Bremen 3, Dawson County 1

## Quarterfinals

Wesleyan 3, Columbus 2  
Oconee County 4, St. Vincents 0  
Sav. Country Day 4, Hebron Christian 1  
Bremen 3, Morgan County 0

## Semifinals

Wesleyan 3, Oconee County 0  
Savannah Country Day 3, Bremen 1

## Final

Wesleyan 3, Savannah Country Day 0

## 2A - BOYS

### Round 1

North Cobb Christian 5, Redan 0  
Model 5, Banks County 0  
Appling County 3, Thomson 0  
Cook, Bye  
Walker 3, Callaway 0  
Fellowship Christian 3, Rockmart 0  
Pierce County 5, Davidson Arts 0  
ACE Charter 4, Worth County 1  
Berrien 5, Central-Macon 0  
Brantley County 5, Johnson-Augusta 0  
Athens Academy 3, North Murray 0  
Landmark Christian 3, Drew Charter 0  
Jeff Davis 5, Rutland 0  
Vidalia 3, Tech Career 0  
East Jackson 3, Murray County 1  
Mt. Paran 3, Elite Scholars 0

### Round 2

Model 4, North Cobb Christian 1  
Appling County 3, Cook 2  
Fellowship Christian 3, Walker 0  
Pierce County 4, ACE Charter 0  
Brantley County 3, Berrien 0  
Athens Academy 3, Landmark Christian 2  
Jeff Davis 4, Vidalia 1  
Mt. Paran 3, East Jackson 0

## Quarterfinals

Model 3, Appling County 0  
Fellowship Christian 3, Pierce County 0



# STATE TENNIS PLAYOFFS - 2023

Brantley County 3, Athens Academy 2  
Mt. Paran 3, Jeff Davis 0

## **Semifinals**

Fellowship Christian 3, Model 0  
Mt. Paran 3, Brantley County 0

## **Final**

Mt. Paran 3, Fellowship Christian 2

## **2A - GIRLS**

### **Round 1**

Mt. Paran 3, Callaway 0  
Rockmart 3, East Jackson 0  
Appling County 3, Thomson 0  
Jeff Davis, Bye  
Landmark Christian 3, N. Cobb Christian 2  
Athens Academy 3, Gordon Central 1  
Brantley County 5, Putnam County 0  
Cook 3, ACE Charter 0

Dodge County 1, Central-Macon 0  
Pierce County 5, Tech Career 0  
Fellowship Christian 3, North Murray 0  
Elite Scholars 3, Drew Charter 0  
Berrien 5, Rutland 0

Savannah Arts 5, Davidson Arts 0  
Model 3, Banks County 0  
Walker 3, Redan 0

### **Round 2**

Mt. Paran 3, Rockmart 2  
Jeff Davis 3, Appling County 1  
Athens Academy 3, Landmark Christian 0  
Brantley County 3, Cook 0  
Pierce County 3, Dodge County 0  
Fellowship Christian 3, Elite Scholars 2  
Berrien 4, Savannah Arts 0

Model 3, Walker 1

### **Quarterfinals**

Jeff Davis 3, Mt. Paran 1  
Brantley County 3, Athens Academy 1  
Pierce County 3, Fellowship Christian 2  
Berrien 3, Model 1

### **Semifinals**

Jeff Davis 3, Brantley County 0  
Berrien 3, Pierce County 2

### **Final**

Jeff Davis 3, Berrien 2

## **A, Div. 1 - BOYS**

### **Round 1**

Mt. Vernon 5, Jasper County 0  
Darlington 3, Athens Christian 0  
Temple 5, Claxton 0  
Bacon County 3, East Laurens 0  
Whitefield Academy 3, Social Circle 0

Tallulah Falls 3, Pepperell 0  
Lamar County 3, Metter 2  
Bleckley County, Bye  
Swainsboro 3, Irwin County 1  
Screven County, Bye  
Rabun County 3, Trion 2

Galloway 3, Prince Avenue 0  
Pelham 4, Dublin 1  
Heard County 3, Bryan County 0  
Armuchee 3, Commerce 2  
Atlanta International, Bye

### **Round 2**

Mt. Vernon 3, Darlington 2  
Bacon County 3, Temple 0  
Whitefield Academy 3, Tallulah Falls 0

Bleckley County 3, Lamar County 0  
Screven County 5, Swainsboro 0  
Galloway 3, Rabun County 0  
Pelham 4, Heard County 1

Atlanta International 3, Armuchee 0

### **Quarterfinals**

Mt. Vernon 4, Bacon County 0  
Whitefield Acad. 3, Bleckley County 0  
Galloway 4, Screven County 0  
Atlanta International 3, Pelham 0

### **Semifinals**

Mt. Vernon 3, Whitefield Acad. 2  
Atlanta International 3, Galloway 0

### **Final**

Atlanta International 3, Mt. Vernon 1

## **A, Div. 1 - GIRLS**

### **Round 1**

Weber School 5, Jasper County 0  
Darlington 3, Elbert County 0  
Bryan County 3, Lamar County 0  
Irwin County 5, East Laurens 0  
Galloway 3, Social Circle 0  
Tallulah Falls 3, Armuchee 0

Claxton 5, Temple 0

Bleckley County, Bye  
Dublin 3, Pelham 2

Screven County, Bye  
Rabun County 3, Pepperell 1  
Mt. Pisgah 3, Prince Avenue 1  
Bacon County 5, Swainsboro 0  
Heard County 3, Metter 0  
Trion 3, Commerce 2  
Mt. Vernon, Bye

### **Round 2**

Darlington 3, Weber School 0  
Irwin County 3, Bryan County 0  
Tallulah Falls 3, Galloway 1  
Bleckley County 3, Claxton 0  
Screven County 5, Dublin 0  
Mt. Pisgah 3, Rabun County 1  
Bacon County 3, Heard County 1  
Mt. Vernon 3, Trion 1

### **Quarterfinals**

Darlington 3, Irwin County 0  
Bleckley County 3, Tallulah Falls 1  
Mt. Pisgah 3, Screven County 0  
Mt. Vernon 4, Bacon County 1

### **Semifinals**

Darlington 3, Bleckley County 0  
Mt. Vernon 3, Mt. Pisgah 0

### **Final**

Darlington 3, Mt. Vernon 2

## **A, Div. 2 - BOYS**

### **Round 1**

Marion County, Bye  
Christian Heritage 5, Lincoln County 0  
Wilcox County 3, Sav. Early Col. 2  
Seminole County, Bye

Georgia Military 3, Furlow Charter 0  
Lake Oconee Academy, Bye  
Jenkins County 3, Hawkinsville 1  
Charlton County 3, Baconton 0  
Miller County 3, Clinch County 1

ECI, Bye

Aquinas 5, Mt Zion-Carroll 0

Johnson County 1, Rainey-McCullers 0

Early County 3, Lanier County 0  
Telfair County, Bye

Bowdon 3, Washington-Wilkes 0  
Taylor County, Bye

### **Round 2**

Christian Heritage 4, Marion County 1  
Seminole County 5, Wilcox County 0  
Lake Oconee Acad. 4, Georgia Military 0  
Charlton County 5, Jenkins County 0  
Miller County 3, ECI 0

Aquinas 3, Johnson County 2  
Early County 3, Telfair County 0  
Taylor County 3, Bowdon 0

### **Quarterfinals**

Seminole County 3, Christian Heritage 1  
Lake Oconee Acad. 3, Charlton County 0

Aquinas 4, Miller County 0

Taylor County 3, Early County 2

### **Semifinals**

Lake Oconee Acad. 3, Seminole County 1  
Taylor County 3, Aquinas 2

### **Final**

Lake Oconee Academy 3, Taylor County 0

## **A, Div. 2 - GIRLS**

### **Round 1**

Marion County 3, Wilkinson County 0  
Christian Her. 5, Lincoln County 0  
Hawkinsville 1, Sav. Early College 0  
Seminole County, Bye

Georgia Military 3, Furlow Charter 0  
Lake Oconee Academy, Bye  
Jenkins County 4, Wilcox County 1  
Lanier County 3, Early County 0  
Charlton County 3, Baconton 0

ECI, Bye

Aquinas 5, Mt. Zion-Carroll 0

Johnson County 5, Rainey-McCullers 0

Miller County 3, Clinch County 0

Telfair County, Bye

Washington-Wilkes 3, Bowdon 1

Taylor County, Bye

### **Round 2**

Christian Heritage 4, Marion County 0  
Seminole County 3, Hawkinsville 0  
Lake Oconee Acad. 3, Georgia Military 0  
Lanier County 4, Jenkins County 0  
ECI 3, Charlton County 2

Johnson County 3, Aquinas 1

Telfair County 4, Miller County 0

Taylor County 3, Washington-Wilkes 0

### **Quarterfinals**

Christian Heritage 3, Seminole County 0  
Lake Oconee Acad. 4, Lanier County 0

Johnson County 3, ECI 0

Telfair County 3, Taylor County 2

### **Semifinals**

Christian Heritage 3, Lake Oconee Acad. 0  
Johnson County 3, Telfair County 1

### **Final**

Christian Heritage 3, Johnson County 0

# STATE TRACK MEETS - 2023

## CLASS 7A - BOYS

### **Discus Throw**

1. White, Jordan, Carrollton, 159-00
2. Herman, Max, Marietta, 158-03
3. Miller, Anthony, Duluth, 157-04
4. Young, James, Lowndes, 154-11

### **High Jump**

1. Brown, Korbin, Kennesaw Mtn., 6-06.00
2. Callahan, Elijah, Archer, 6-04.00
2. Ezegbo, Ifeanyi Chukwu, Hillgrove, 6-04.00
4. Milliner, Elijah, Brookwood, 6-04.00
4. Hilliard, Jalen, McEachern, 6-04.00

### **Long Jump**

1. Alexander, Joseph, Mill Creek, 24-03.75
2. Brown, Korbin, Kennesaw Mtn., 23-10.00
3. Patterson, Kam' Aron, Newton, 23-03.50
4. Ford, Pierre, South Gwinnett, 23-02.50

### **Pole Vault**

1. McLain, Connor, Walton, 15-00.00
2. Lamb, Timothy, Mill Creek, 14-06.00
3. Frederick, Will, Marietta, 14-06.00
4. Thiewes, Shea, North Cobb, 14-00.00

### **Shot Put**

1. Ugokwe, Lota, Walton, 53-04.00
2. Smith, Cortez, Parkview, 53-02.00
3. Herman, Max, Marietta, 51-04.75
4. Inan, Omer, Walton, 51-01.25

### **Triple Jump**

1. Dahunsi, Devin, Milton, 48-00.50
2. Horton, Josh, Osborne, 47-03.50
3. Ivaniciuc, Jayden, Buford, 46-10.50
4. Stuart, Femi, Walton, 46-06.50

### **4x800 Meter Relay**

1. Carrollton 7:46.62 (Jennings, Will; Martinson, Noah; Moseley, Nathan; Sipes, Joshua)
2. Lambert 7:48.56 (Latimer, Reid; Patel, Kushan; Hogsed, Jackson; Miller, Matthew)
3. Harrison 7:51.45 (Swingley, Grayson; Huggins, Clint; Sellier, Sterling; Brownlee, Bryce)
4. Archer 7:54.92 (Anderson, Austin; Brooks, Braylen; McCartney, Steven; Robbins, Conner)

### **4x100 Meter Relay**

1. Westlake 40.31# (Terrell, Avieon; Njie, Sidi; Thomas, Ji'den; Smith, Antwan)
2. Buford 40.40 (Allen, Jordan; Bolden, KJ; Gilbert, Osiris; Colbert, Jeremiah)
3. Archer 41.20 (Dixon, Andru; Okoye, Zion; Alexander, Colby; Alexander, Chad)
4. Mill Creek 41.62 (Miller, Solomon; McIntyre, Josiah; Bolden, Kaymon; Miller, Malachi)

### **1600 Meter Run**

1. Bergey, Ben, South Forsyth, 4:12.94
2. Hogsed, Jackson, Lambert, 4:17.79
3. Patel, Kushan, Lambert, 4:17.92
4. Minecci, Joseph, Walton, 4:18.78

### **400 Meter Dash**

1. Njie, Sidi, Westlake, 45.46#
2. Pearson, Ervin, Buford, 46.19
3. Clark, Devin, Marietta, 46.89
4. Terrell, Caden, North Paulding, 47.71

### **100 Meter Dash**

1. Nelson, Chris, South Forsyth, 10.22#
2. Phillips, Dwight, Pebblebrook, 10.24
3. Colbert, Jeremiah, Buford, 10.60
4. Shakespeare, Caleb, Brookwood, 10.65

### **110 Meter Hurdles**

1. Crum, Joshua, Brookwood, 14.10
2. Knight, Keonte, Parkview, 14.11
3. Guadiano, Cameron, Westlake, 14.22
4. James, Daniel, McEachern, 14.44

### **800 Meter Run**

1. Jones, Chance, Dacula, 1:52.24
2. Patell, Zach, Milton, 1:54.46
3. Brown, Owynn, Grayson, 1:54.49
4. Thompson, Keayari, Westlake, 1:54.53

### **200 Meter Dash**

1. Nelson, Chris, South Forsyth, 20.69#
2. Njie, Sidi, Westlake, 20.82
3. Colbert, Jeremiah, Buford, 21.28
4. Goffe, Joshua, East Coweta, 21.38

### **300 Meter Hurdles**

1. Crum, Joshua, Brookwood, 37.31
2. Roberts, Darris, Valdosta, 37.44
3. Dopson, Bryce, Brookwood, 38.12
4. Dyer, Sean, Grayson, 38.32

### **4x400 Meter Relay**

1. Buford 3:11.24# (Knight, Alexander; Colbert, Jeremiah; Ervin, Ethan; Pearson, Ervin)
2. Grayson 3:12.17 (Gaffney, Chad; Dyer, Sean; Thomas, Elijah; Daniels, Brady)
3. Valdosta 3:16.29 (Roberson, Timothy; Coxfield, Donte; Roberts, Darris; Turner, Travis)
4. Lowndes 3:19.26 (Thomas, Kaeron; Fulton, Robert; Miller, Matthew; Snellgrove, Tayt)

### **4x200 Meter Relay**

1. Westlake 1:25.40 (Terrell, Avieon; Smith, Antwan; Preston, Nasir; Morton, Hollis)
2. Marietta 1:25.99 (Sanders, Isaiah; Frederick, Will; Ashley, Nakari; Clark, Devin)
3. Campbell 1:26.16 (Stone, Isaiah; Hayes, Aveion; Walker, Justin; Charles, Elijah)
4. Denmark 1:26.63 (Jennings, Kamden; Louis, JJ; Branch, Hayden; Easley, Ryan)

### **3200 Meter Run**

1. Bergey, Ben, South Forsyth, 9:15.71
2. Patel, Kushan, Lambert, 9:20.94
3. Hogsed, Jackson, Lambert, 9:21.01
4. Minecci, Joseph, Walton, 9:28.85

### **Team Scores**

1. Westlake.....60
2. Walton.....46
2. Buford.....46
4. Lambert.....40

## Class 7A GIRLS

### **Discus Throw**

1. Johnson, Zoie, Osborne, 143-01
2. Igberaese, Noelle, Dacula, 141-06
3. Hannon, Kameryn, Grayson, 136-10
4. Callwood, Kijana, Grayson, 133-05

### **High Jump**

1. Nembhard, Danah, Dacula 5-06.00
2. Davis, Ariyah, Lowndes, 5-04.00
3. Lockette, Zion, Westlake, 5-04.00
4. Hines, Mya, Peachtree Ridge, 5-04.00
4. Zorzoli, Bella, West Forsyth, 5-04.00
4. Hunter, Trinity, Lowndes, 5-04.00

### **Long Jump**

1. Wright, Jaci, Buford, 19-04.50
2. McConnehead, Kaylan, Lowndes, 18-08.25
3. Jefferson, Caylie, Westlake, 18-06.75

4. Robinson, Jasmine, North Cobb, 18-02.00

### **Pole Vault**

1. Lopez-Ramirez, Silvana, W. Forsyth, 12-00.00
2. Freeland, Victoria, Mill Creek, 11-06.00
3. Kimsey, Lydia, Forsyth Central, 11-06.00
4. Phillips, Madison, Carrollton, 11-00.00

### **Shot Put**

1. Akintayo, Christianne, Archer, 44-07.50
2. Igberaese, Noelle, Dacula 44-04.25
3. Gilbert, Jayla, Carrollton, 43-10.00
4. Abrams, Alayna, Marietta, 41-06.75

### **Triple Jump**

1. Nembhard, Danah, Dacula 40-09.00
2. McConnehead, Kaylan, Lowndes, 39-10.75
3. Tagbo, Adaora, North Gwinnett 39-06.75
4. Tidwell, Maleah, Campbell, 38-09.00

### **4x800 Meter Relay**

1. Marietta 9:18.77# (McQueen, Kristal; Hart, Nora; Nesmith, Mary; McVicker, Brooklyn)
2. Harrison 9:28.29 (Curtis, Kate; Longo, Lidia; Villamar, Angelina; McGarity, Samantha)
3. Brookwood 9:30.71 (Wardle, Allie; Felton, Macy; Thurman, Trinity; Tackett, Caelyn)
4. West Forsyth 9:36.61 (Krogman, Tess; Kyle, Sophie; Nix, Ryleigh; Crawford, Calli)

### **4x100 Meter Relay**

1. Westlake 46.35 (Billings, Jaden; Jefferson, Caylie; Jones, Zaniyah; Kinard, Adyn)
2. Archer 47.12 (Okoye, Princess; O'Gwin, Tanii; Sessom, Kyndall)
3. Lambert 47.25 (Ezekiel, Sade; Harris, Susie; Jabbie, Salima; Jabbie, Aminah)
4. North Cobb 47.56 (Arnold, Mariah; Beaumont, Keira; Mbadinga, Eliana; Mwenja, Lois)

### **1600 Meter Run**

1. Nesmith, Mary, Marietta, 5:02.38
2. Felton, Macy, Brookwood, 5:05.67
3. Wardle, Allie, Brookwood, 5:05.68
4. Pavese, Lexi, Cherokee, 5:11.03

### **400 Meter Dash**

1. Harris, Sydney, Buford, 52.83
2. Tate, Serena, Brookwood, 53.92
3. Green, Lailah, Discovery, 54.58
4. Burt, Akira, Richmond Hill, 55.05

### **100 Meter Dash**

1. Davis, Ryan, Hillgrove, 11.47
2. Beaumont, Keira, North Cobb, 11.67
3. Hagans, Amoi, Newton, 11.70
4. Kinard, Adyn, Westlake, 11.80

### **100 Meter Hurdles**

1. Witherspoon, Kalani, Carrollton, 13.71
2. Wright, Jaci, Buford, 13.80
3. Ziglior, Zoe, Harrison, 14.28
4. Robinson, Jasmine, North Cobb, 14.28

### **800 Meter Run**

1. Nesmith, Mary, Marietta, 2:11.75
2. Johnson, Kendall, Lowndes, 2:15.84
3. Felton, Macy, Brookwood 2:16.06
4. Anderson, Sydney, Milton, 2:17.79

### **200 Meter Dash**

1. Davis, Ryan, Hillgrove, 23.54
2. Hagans, Amoi, Newton, 24.04
3. Tate, Serena, Brookwood, 24.07
4. Harris, Sydney, Buford, 24.21

# STATE TRACK MEETS - 2023

## 300 Meter Hurdles

1. Robinson, Jasmine, North Cobb, 41.80
2. Jones, Zaniyah, Westlake, 43.23
3. Wright, Ron-Niah, Peachtree Ridge, 43.66
4. Billings, Jaden, Westlake, 43.82

## 4x400 Meter Relay

1. Westlake 3:46.32 (Kinard, Adyn; McGee, Mia; Holmes, Zhai; Jones, Zaniyah)
2. Brookwood 3:50.69 (Davis, Zya; Campbell, Madison; Rouse, Solae; Bass, Elle)
3. Buford 3:50.96 (Brown, Dominique; Thomas, Arianna; Harris, Sydney 12)
4. Rich. Hill 3:51.08 (Hamlin, Alexa; Heileman, Kalyn; Lawrence, Jayla; Burt, Akira)

## 4x200 Meter Relay

1. Brookwood 1:36.59# (Tate, Serena; Jones, Janai; Bass, Elle; Campbell, Madison)
2. Westlake 1:37.59 (Jefferson, Caylie; Billings, Jaden; Holmes, Zhai; Lockette, Zion)
3. Rich. Hill 1:38.25 (Wood, Jasmine; Burt, Akira; Heileman, Kalyn; Lawrence, Jayla)
4. Lambert 1:38.84 (Ezekiel, Sade; Harris, Susie; Jabbie, Salima; Jabbie, Aminah)

## 3200 Meter Run

1. Nesmith, Mary, Marietta, 10:51.62
2. Jones, Maddie, Marietta, 11:00.19
3. Hart, Nora, Marietta, 11:01.65
4. Wells, Jewel, Mill Creek, 11:05.96

## Team Scores

- |                   |         |
|-------------------|---------|
| 1. Westlake.....  | 73.3333 |
| 2. Marietta.....  | 70      |
| 3. Brookwood..... | 62      |
| 4. Lowndes.....   | 45      |

## Class 6A BOYS

### High Jump

1. Rankin, Riyon, Brunswick 7-03.75#
2. Yehudah, Malachi, Hughes, 6-10.00
3. Crosswhite, Nicolas, New Manchester, 6-08.00
4. Shutts, Jackson, Creekview 6-06.00

### Pole Vault

1. Gibson, Zane, Etowah, 15-06.00
2. Peoples, Brandon, Houston County, 15-00.00
3. Venezia, Grayson, Creekview, 15-00.00
4. Grachen, Ryan, Lassiter, 15-00.00

### Long Jump

1. Crosswhite, Nicolas, New Manchester, 23-05.00
2. Hopkins, Adams, Thomas Co. Cent., 23-04.00
3. Stradley, Luke, Etowah, 22-07.00
4. Woolfork, Jaylen, Lovejoy, 22-02.50

### Triple Jump

1. Crosswhite, Nicolas, New Manchester, 49-02.00
2. Crite, Ethan, Roswell, 48-01.50
3. Barker, Eric, Shiloh, 46-09.50
4. Anderson, NaJiib, Rockdale Co., 46-08.25

### Discus Throw

1. Hines, Tahir, Allatoona, 168-04
2. Baltimore Jr, Timothy, Rome, 159-10
3. Chosewood, Brad, Habersham Cent., 155-02
4. Jackson, Jayden, Houston County, 154-11

### Shot Put

1. Hines, Tahir, Allatoona, 57-01.00
2. Chosewood, Brad, Habersham Cent., 55-03.00
3. Puckett, Bryan, Lovejoy, 51-03.50
4. Woods, Jack, St. Pius, 50-09.50

## 4x800 Meter Relay

1. Etowah 7:53.46# (Balogh, Andrew; Eye, Seth; Rountree, Wes; Pierce, Daniel)
2. Marist 7:55.01 (Hanemann, Liam; Latham, Tommy; Gaffney, Ian; Patin, Jude)
3. Roswell 7:57.53 (Ashmead, Collin; Jimenez, Ethan; Williams, Chase; Rhodes, Thomas)
4. Alexander 7:58.52 (Guidry, Cayden; Guidry, Marcus; Mckenzie, Justyn; Sleight, Josh)

## 110 Meter Hurdles

1. Benjamin, George, Shiloh, 13.82
2. Southerland, Bryce, Shiloh, 14.12
3. Branch, Kalib, Lovejoy, 14.15
4. Butler, Michael, Woodward Academy, 14.76

## 100 Meter Dash

1. Singleton, Eric, Alexander, 10.35
2. Gleaton, Maurice, Hughes, 10.37
3. Scott, Jaylen, Mundys Mill, 10.58
4. Murray, Carl, North Atlanta 10.63

## 4x200 Meter Relay

1. N. Atlanta 1:25.84# (Owens, Deshawn; Murray, Carl; Ramsey, Caleb; Malcolm Jr, Darius)
2. Veterans 1:26.49 (Bryant, Kaname; Mitchell, Samuel; Ingram, Monterrious; Swift, Kylan)
3. Lovejoy 1:26.65 (Branch, Kalib; Bonelli, Amaru; White, Dequavious; Woolfork, Jaylen)
4. Morrow 1:27.67 (Brinson, Lamont; Rafe, Clenton; Therrell, Janorris; Dixon, Julius)

## 1600 Meter Run

1. Latham, Tommy, Marist, 4:16.55
2. Jessup, John, Gainesville, 4:17.99
3. Balogh, Andrew, Etowah, 4:18.32
4. Proffitt, Conner, Gainesville, 4:20.48

## 4x100 Meter Relay

1. Hughes 40.55# (Barnes, Jaden; Gleaton, Maurice; Page, Dorian; Lockhart, Robert)
2. N. Atlanta 41.80 (Ramsey, Caleb; Murray, Carl; Malcolm Jr, Darius; Woods, Mason)
3. Morrow 42.01 (Brinson, Lamont; Rafe, Clenton; Therrell, Janorris; Dixon, Julius)
4. Rome 42.23 (Johnson, Ja'quarious; Carey, Antwion; Daniel, DeKaylon; Winston, Jalen)

## 400 Meter Dash

1. Singleton, Eric, Alexander, 46.30#
2. Geter, Trey, Newnan, 47.54
3. Quilici, Vincent, Rome, 48.36
4. McReynolds, Sidney, North Atlanta, 48.78

## 300 Meter Hurdles

1. Jarrett, Shawn, Mundys Mill, 37.61
2. Wells, Dmitry, Hughes, 38.06
3. Benjamin, George, Shiloh, 38.46
4. Harvey, Caleb, Veterans, 38.65

## 800 Meter Run

1. Balogh, Andrew, Etowah, 1:54.51
2. Kennedy, Kamren, Veterans, 1:55.26
3. Jessup, John, Gainesville, 1:55.72
4. Williams, Chase, Roswell, 1:55.96

## 200 Meter Dash

1. Gleaton, Maurice, Hughes, 20.81#
2. Singleton, Eric, Alexander, 20.90
3. Murray, Carl, North Atlanta, 21.47
4. Page, Dorian, Hughes, 21.61

## 3200 Meter Run

1. Latham, Tommy, Marist 9:12.92
2. Proffitt, Conner, Gainesville, 9:14.42
3. Wright, Tucker, Rome, 9:26.71

4. Maloney, Dermot, Pope, 9:28.43

## 4x400 Meter Relay

1. Rockdale 3:18.44 (Jefferson, Nicholas; Moore, Makaibri; Charlery, Finley; Jackson, Joshua)
2. Veterans 3:18.52 (Bryant, Kaname; Kennedy, Kamren; Watson, Matthias; Harvey, Caleb)
3. Hughes 3:18.64 (Lewis, Kai; Williams, Christian; Wells, Dmitry; Arnold, Torey)
4. Alexander 3:19.10 (Guidry, Cayden; Singleton, Eric; Smith, Dashawn; Vick, Elijah)

## Team Scores

- |                       |      |
|-----------------------|------|
| 1. Hughes.....        | 59   |
| 2. North Atlanta..... | 51   |
| 3. Etowah.....        | 49.5 |
| 4. Shiloh.....        | 44   |

## Class 6A GIRLS

### High Jump

1. Pearson, Ashari, New Manchester, 5-07.00
2. Adams, Queens, Jonesboro, 5-04.00
3. Rehal, Amrit, Johns Creek, 5-04.00
4. Johnson, Angella, Jonesboro, 5-02.00

### Pole Vault

1. Hight, Keira, Sequoyah, 12-00.00
2. Cho, Ansley, Marist, 11-00.00
3. Brown, Charlotte, North Atlanta, 10-06.00
4. Acker, Julia, Pope, 10-06.00

### Long Jump

1. Gordon, Alisa, Alexander, 18-10.25
2. Lee, Jailah, Veterans, 18-02.50
3. Key, Gabby, Pope, 18-02.00
4. Ivery, Paris, Grovetown, 18-00.50

### Triple Jump

1. Gordon, Alisa, Alexander, 41-09.50#
2. Srigboh, Aseye, Alexander, 39-11.50
3. Lee, Jailah, Veterans, 39-04.75
4. Stargell, Kayleigh, North Atlanta, 38-09.50

### Discus Throw

1. Soli, Skylar, Douglas County, 144-09
2. Rogan, Neely, Apalachee, 133-00.25
3. Bowe, Anderson, Dunwoody, 132-08
4. Steines, Maya, Alpharetta, 126-02

### Shot Put

1. McKinney, Kyndal, Woodstock, 44-06.00
2. Steines, Maya, Alpharetta, 43-01.00
3. Soli, Skylar, Douglas County, 43-00.00
4. Rogan, Neely, Apalachee, 41-08.00

## 4x800 Meter Relay

1. St. Pius 9:21.48# (Stone, Ella; Boyle, Lane; Schemmel, Hannah; Garcia, Zoe)
2. Marist 9:29.70 (Little, Ruby; Chambless, Stella; Selover, Kate; Waddell, Maeve)
3. N. Atlanta 9:37.98 (Hamilton, Sarah Anne; Townsend, Catherine; Coogan, Malley; Williams, Camille)
4. Gainesville 9:38.05 (Hartman, Samantha; Graciano, Josabeth; Hoyos, Arianny; Torres, Vanessa)

## 100 Meter Hurdles

1. Powell, Olivia, Woodward Academy, 13.44
2. Myers, Kennedy, Lakeside-Evans 14.36
3. Bailey, Sole, Jackson County, 14.70
4. Gayle, Mataya, River Ridge, 14.70

## 100 Meter Dash

1. Teasley, Victoria, Alexander, 11.73
2. Williams, Chelsea, Woodward, 11.94

# STATE TRACK MEETS - 2023

3. Ray, Jada, Lakeside-Evans, 12.05
4. Edet, Ewomazino, Etowah, 12.06

## 4x200 Meter Relay

1. Woodward 1:39.08# (August, Makai; Williams-Zachery, Madison; Conner, Kenyah; Seward, Savy)
2. Alexander 1:39.21 (Crowder, Camille; Teasley, Victoria; Srigboh, Aseye; Lowe, Aliyah)
3. Alpharetta 1:39.62 (Jones, Jaelyn; Russell, Janae; Richard, Sophia; Mitchell, Kiley)
4. Etowah 1:39.79 (Edet, Ewomazino; Stevenson, Kira; Williams, Kamryn; Peoples, Kamryn)

## 1600 Meter Run

1. Schemmel, Hannah, St. Pius, 5:16.63
2. Little, Ruby, Marist, 5:18.02
3. Petersen, Claire, Blessed Trinity, 5:19.47
4. Dollar, Katelynn, Creekview, 5:22.99

## 4x100 Meter Relay

1. Woodward 45.54# (Williams, Chelsea; Glee, Sydney; Conner, Kenyah; Powell, Olivia)
2. Lakeside-Evans 46.92 (Myers, Kennedy; Carver, Rikki; Walker, Sarah; Ray, Jada)
3. Etowah 47.49 (Edet, Ewomazino; Crane, Gabrielle; Stevenson, Kira; Peoples, Kamryn)
4. Veterans 48.14 (Barley, Krysllyn; Clarke, Gabriella; Cook, Serena; Lee, Jailah)

## 400 Meter Dash

1. Mitchell, Kiley, Alpharetta, 54.40
2. Martin, Yasmine, South Cobb, 54.42
3. Brister, Maddison, Grovetown, 55.56
4. Glee, Sydney, Woodward Academy, 55.60

## 300 Meter Hurdles

1. Powell, Olivia, Woodward Academy, 41.26#
2. Head, Sarah, Lee County, 42.91
3. Myers, Kennedy, Lakeside-Evans, 43.13
4. Stargell, Kayleigh, North Atlanta, 43.86

## 800 Meter Run

1. Awolaye, Oluwatosin, South Cobb, 2:08.28#
2. Conner, Kenyah, Woodward, 2:08.79
3. Wright, Alexis, Lanier, 2:14.09
4. Stone, Ella, St. Pius, 2:15.54

## 200 Meter Dash

1. Teasley, Victoria, Alexander, 24.04
2. Williams, Chelsea, Woodward, 24.40
3. Glee, Sydney, Woodward, 24.65
4. Richard, Sophia, Alpharetta, 24.72

## 3200 Meter Run

1. Schemmel, Hannah, St. Pius, 10:32.51
2. Dollar, Katelynn, Creekview, 10:44.56
3. Shelton, Claire, Dunwoody, 10:52.16
4. Ray, London, Blessed Trinity, 10:53.45

## 4x400 Meter Relay

1. Woodward 3:44.63 (Conner, Kenyah; Gardner, Madison; Glee, Sydney; Powell, Olivia)
2. South Cobb 3:52.75 (Awolaye, Oluwatosin; Martin, Yasmine; Odom, Camryn; Awolaye, Oluwatoyosi)
3. Lakeside-Evans 3:53.86 (Carver, Rikki; Ray, Jada; Walker, Sarah; Myers, Kennedy)
4. Alexander 3:58.79 (Adams, Cortney; Lowe, Aliyah; Teasley, Victoria; Srigboh, Aseye)

## Team Scores

1. Woodward Academy.....89.5
2. Alexander.....70
3. Marist.....44
3. Alpharetta.....44

## Class 5A BOYS

### Discus Throw

1. Christian Dixon, Dutchtown, 173-01
2. John Pacey, Tucker, 168-10
3. Kristyane Gregory, Calhoun, 157-01
4. Connor Whaley Tucker, 156-01

### High Jump

1. Mekhi Oliver, Dutchtown, 6-06.00
2. Ian Hodge, Tucker, 6-06.00
3. Kah'mani Zachery, Chapel Hill, 6-06.00
4. Royal Washington, Decatur, 6-04.00

### Long Jump

1. Hasaan Sykes, Tucker, 22-05.25
2. Miles Collier, Chapel Hill, 22-02.00
3. Davarri Barthell, Dutchtown, 22-01.75
4. Sammy Brown, Jefferson, 22-01.75

### Pole Vault

1. Jordan Frank, North Springs 15-00.00
2. Peyton Hanson, Greenbrier, 14-06.00
3. Ryan McKinney, Greenbrier, 14-00.00
4. Adam Henley, Jefferson, 13-06.00

### Shot Put

1. Alex Henry, Lithia Springs, 55-00.00
2. Dylan Robbins, Loganville, 53-10.50
3. Emorrie Foskey, Winder-Barrow, 53-07.25
4. Lamone Hill Jr., Dutchtown, 53-01.00

### Triple Jump

1. Muhammad Shareef, Statesboro, 45-08.75
2. Ricardo Lewis, Midtown, 45-08.25
3. Elijah Powell, Chamblee, 44-10.50
4. Marqavious Saboor, Kell, 44-09.25

## 4x100 Meter Relay

1. Dutchtown 41.44 (Tyler Burch; Tyler Dixon; Jaden Lemon; Justin Harper)
2. Tucker 41.46 (Jordan McCoy; Ethan Sanders; Hasaan Sykes; Christian Whitmore)
3. Clarke Cen. 42.14 (Braylen Fleming; Christopher Goss; Bartz Gillespie Jr.; Shavique Bascus)
4. Villa Rica 42.23 (Jaquess Dunson; Trey Campbell; Abram Benson; King Neal)

## 1600 Meter Run

1. Chris Connolly, Chattahoochee, 4:20.18
2. Diego Santiago, Chattahoochee, 4:21.15
3. William Carlton, Decatur, 4:24.46
4. Solomon Johnson, Chapel Hill, 4:26.16

## 400 Meter Dash

1. Jaylen Marsh, Creekside, 47.80
2. Mekhi Oliver, Dutchtown, 48.79
3. Ryan Gruss, Flowery Branch, 48.83
4. Jordan Edwards, Eastside, 48.84

## 100 Meter Dash

1. Shavique Bascus, Clarke Central, 10.56
2. Zion Ragins, Jones County, 10.63
3. Kendrick Price, Cartersville, 10.68
4. Tyler Dixon, Dutchtown, 10.69

## 110 Meter Hurdles

1. Nasia Lee, Dutchtown, 13.89
2. Jadon Thomason, Calhoun, 14.18
3. Ibrahim Bangura, Cambridge, 14.65
4. Miles Collier, Chapel Hill, 15.09

## 800 Meter Run

1. Elias Harrison, Bancker 1:56.04
2. Omari Sawyer, M.L. King, 1:56.64
3. William Elder, Chamblee, 1:56.70
4. Josiah Asfaw, GACS, 1:56.93

## 200 Meter Dash

1. Shavique Bascus, Clarke Central, 21.12
2. Zion Ragins, Jones County, 21.64
3. Christian Whitmore, Tucker, 21.79
4. Jonas Davis, Eastside, 22.01

## 300 Meter Hurdles

1. Nasia Lee, Dutchtown, 37.77
2. Jadon Thomason, Calhoun 37.89
3. Dominick Lawshea, Cambridge, 38.57
4. Ibrahim Bangura, Cambridge, 38.91

## 3200 Meter Run

1. Diego Santiago Chattahoochee, 9:23.19
2. Chris Connolly Chattahoochee, 9:28.70
3. Jacob Pullen, Jackson-Atlanta, 9:37.62
4. Finn Herlihy Chapel Hill, 9:39.36

## 4x400 Meter Relay

1. Creekside 3:17.15 (Roderick McCrary; Isaiah Nombre; Jaylen Marsh; Daiquan White)
2. Eastside 3:19.24 (Jordan Edwards; Jaden Dix; Jonas Davis; Jayson Yao)
3. Dutchtown 3:20.15 (Davarri Barthell; Jaden Lemon; Christian Thompson; Mekhi Oliver)
4. Locust Grove 3:20.83 (Paul Blouin; Darryon Harris; Zechariah Addison; Jaylen Patterson)

## 4x800 Meter Relay

1. Eagle's Landing 7:57.48 (Delton White; Nyciem Belvin; Christopher Gooden; Altaveon Grant)
2. Chattahoochee 7:59.00 (Alex Johnson; Chris Connolly; Luke Shorrock; Diego Santiago)
3. Chapel Hill 8:01.39 (Jabari Bempah; Malik Haskins; Rashad Wright; Solomon Johnson)
4. M.L. King 8:03.80 (Kameron Sutton; Braylin Grier; Jordan Saunders; Omari Sawyer)

## 4x200 Meter Relay

1. Dutchtown 1:26.31 (Tyler Burch; Tyler Dixon; Davarri Barthell; Justin Harper)
2. GACS 1:26.76 (Gabriel Daniels; Charles Phillips; Jaden Henry; Aidan McKinnie)
3. Heritage-Con. 1:26.92 (Collin Hendersony; Tyler Young; Bryson Shears; Quacy Virgo)
4. Creekside 1:27.28 (Daiquan White; Jaylen Marsh; Ricky McCrary; Isaiah Nombre)

## Team Scores

1. Dutchtown.....99
2. Tucker.....51
3. Chapel Hill.....47
4. Chattahoochee.....44

## Class 5A GIRLS

### Discus Throw

1. Kayley Bednarek, Loganville, 133-10
2. Nyla Wilson, Eagle's Landing, 133-02
3. Jakayla Arnold, Jackson-Atlanta, 127-08
4. Eve Knight, Jefferson, 125-04

### High Jump

1. Oluchi Ugbojah, McIntosh, 5-06.00
2. Lilah Versluis, Cambridge, 5-06.00
3. Julia Versluis, Cambridge, 5-04.00
3. Ta'lyana Anderson, Bradwell Institute, 5-04.00

### Long Jump

1. Ava Kitchings, GACS, 19-07.75
2. Naa Adua Annan, Chamblee, 17-10.75
3. Nijah Lewis, Tucker, 17-10.00
4. Jacoria Leonard, Bradwell Institute, 17-08.00

### Pole Vault

1. Julia Versluis, Cambridge, 11-00.00
2. Ella Kulnieszewski, Jefferson, 11-00.00

# STATE TRACK MEETS - 2023

3. Layla Keadle, North Springs, 11-00.00
4. Emi Sarago, Chamblee, 10-00.00

## Shot Put

1. Jasmine Baxter, Mays, 39-10.50
2. Katelyn Mendoza, Tucker, 37-00.50
3. Kristan Simmons, Tucker, 36-02.50
4. Nyla Wilson, Eagle's Landing, 35-09.25

## Triple Jump

1. Lilah Versluis, Cambridge, 38-01.75
2. Blessed Diogo, Jenkins, 37-07.50
3. Julia Versluis, Cambridge, 37-05.75
4. Lauren Jackson, Union Grove, 37-01.00

## 4x100 Meter Relay

1. GACS 46.98 (Ivy Holland; Nia Wilson; Ava Kitchings; Elizabeth Clout)
2. Lithia Springs 47.63 (Nevah Shedrick; Destiny Jenkins; Nikylah Crawley; Le'Asia Housel)
3. Jefferson 48.22 (Aubrianna Ferrero; Rihanna Wood; Hannah Howard; Rileigh Harrison)
4. Bradwell 48.45 (Ta'tyana Anderson; Taniyah Bowman; Jacoria Leonard; Alazia Frazier)

## 1600 Meter Run

1. Lottie Chappell, North Springs, 5:02.15
2. Sophie D'Elena, Decatur, 5:03.56
3. Bella Brick, Flowery Branch, 5:11.93
4. Morgan Collins, GACS, 5:14.10

## 400 Meter Dash

1. Davenae Fagan, Arabia Mountain, 54.90
2. Gabrielle Dandridge, Cambridge, 56.08
3. Olivia Cosby, Northside-Columbus, 56.21
4. Kaylin Jackson, Banneker, 56.32

## 100 Meter Dash

1. Nia Wilson, GACS, 11.51
2. Davenae Fagan, Arabia Mountain, 11.71
3. Jori Savage, Heritage-Conyers, 12.11
4. Destiny Jenkins, Lithia Springs, 12.13

## 100 Meter Hurdles

1. Jakayla Campbell, Banneker, 14.24
2. Danayja Harper, Midtown, 14.45
3. Ava Amey, Arabia Mountain, 14.91
4. Blessed Diogo, Jenkins, 15.10

## 800 Meter Run

1. Morgan Collins, GACS, 2:11.87
2. Kaylin Jackson, Banneker, 2:13.62
3. Sophie D'Elena, Decatur, 2:13.73
4. Natalie Tully, North Springs, 2:15.75

## 200 Meter Dash

1. Davenae Fagan, Arabia Mountain, 23.73
2. Nia Wilson, GACS, 23.99
3. Destiny Jenkins, Lithia Springs, 24.69
4. Anetra Graham, Greenbrier, 24.95

## 300 Meter Hurdles

1. Danayja Harper, Midtown, 42.19
2. India Thorpe, M.L. King, 42.97
3. Celeania Rollerson, Heritage-Con., 44.91
4. Taylor Daniels, Lithia Springs, 45.32

## 3200 Meter Run

1. Lottie Chappell, North Springs, 11:10.65
2. Effie Ward, Harris Co., 11:13.48
3. Francie Butts, Chapel Hill, 11:19.85
4. Anna Blaich, Decatur, 11:27.39

## 4x400 Meter Relay

1. Banneker 3:57.24 (Taylor Bryant; Jakayla Campbell; Kaylin Jackson; Trinity Jordan)

2. GACS 3:57.60 (Morgan Collins; Nia Wilson; Ivy Holland; Ava Kitchings)
3. Lithia Springs 3:57.72 (Le'Asia Housel; Dasia Nails; Calaya Montgomery; Gabrielle Lankford)
4. Eastside 4:00.40 (Kamarra Trisch; Lauren Davis; Jada Sanders; Jayda Duplessis)

## 4x800 Meter Relay

1. Decatur 9:47.85 (Anna Blaich; Kate Sherwood; Tallulah Wall; Gabriella Malerba)
2. McIntosh 9:52.80 (Madeline Abbott; Kirsten Rose; Katerina Soroka; Noelle Sullivan)
3. Greenbrier 9:54.29 (Caleigh Munro; Millie Quick; Allison Sidley; Clara Stewart)
4. Chamblee 10:01.44 (Madeline Harron; Talley Pendleton; Paige Pendleton; Shea Fagan)

## 4x200 Meter Relay

1. Heritage-Con., 1:39.29 (Mckenzie Burnett; Alyssa Crump; Insiya Magee; Jori Savage)
2. Bradwell Institute 1:41.78 (Ta'tyana Anderson; Taniyah Bowman; Tanieha Bowman; Jacoria Leonard)
3. Greenbrier 1:41.98 (Kennedy McDonald; Anetra Graham; Alexcia Jeter; Candace Martin)
4. Banneker 1:42.05 (Jakayla Campbell; Trinity Jordan; Ebony Whyte; Jayla Walker)

## Team Scores

1. Greater Atlanta Christian.....61
2. Cambridge.....54.5
3. Heritage-Conyers.....45
4. North Springs.....42
4. Banneker .....42

## Class 4A BOYS

### Discus Throw

1. Josh Phifer, Starrs Mill, 161-04
2. Yashawn Butler, LaGrange, 157-01
3. Cedric Irvin, Stockbridge, 156-08
4. Nicholas Lane, Westover, 152-10

### High Jump

1. Tito Alofe, Starrs Mill, 6-08.00
2. Tymone Washington, Woodland-Hen., 6-06.00
3. Gage Voyles, Northwest Whitfield, 6-04.00
4. Luke Melton, Trinity Christian, 6-04.00

### Long Jump

1. Isaiah Rayner, Westover, 22-11.00
2. Tito Alofe, Starrs Mill, 22-08.50
3. Jhace Justice, Cherokee Bluff, 22-02.50
4. Braeden Ofosu-Kwarteng, Whitewater, 22-02.00

### Pole Vault

1. Owen Wilkinson, Central-Carroll, 14-06.00
2. Connor White, Holy Innocents', 13-00.00
3. Jackson Ross, Trinity Christian, 13-00.00
4. Nicholas Andrews, Trinity Christ., 12-06.00
4. Patrick Walsh, Westminster, 12-06.00

### Shot Put

1. Phillips Moore, Westminster, 58-09.50
2. Jared Moore, Starrs Mill, 56-09.50
3. Greigh Joseph, Starrs Mill, 53-10.00
4. Michael Horton, Westside-Macon, 52-09.50

### Triple Jump

1. Tito Alofe, Starrs Mill, 48-04.50
2. Isaiah Rayner, Westover, 46-08.50
3. Tavares Simmons, Perry, 46-05.00
4. Drew Bomar, Holy Innocents', 45-05.00

### 4x800 Meter Relay

1. Westminster 8:00.00# (Esfan Daya; Rohan Gazula; Joseph Jacquot; Willem Mandel)

2. Starr's Mill 8:02.85 (Ethan Aguilera-Morton; Denver Oates; Bankson Roach; Cannon McFall)
3. E. Forsyth 8:07.60 (Alex Arrambide; Thomas Pederson; Ryder Holland; William Knight)
4. Fayette County 8:10.73 (Allen Sulton; Zakhari Rivers; Shannon Pue; Justin Warner)

## 4x100 Meter Relay

1. Hampton 41.30 (Omarii James; Prince Derring; Cameron Goggins; Lassale Hewlett)
2. SW DeKalb 41.41 (Taylor Anderson; Xzaviah Taylor; Xavier Turner; Therrian Alexander III)
3. Woodland-Henry 41.89 (Xavier Woodard; Dominiq Northington; Julian Dixon; Cassie Scott)
4. Fayette County 41.96 (Julian Hall; Kamran Kilpatrick; Eric Hence; Trenneddy Whatley)

## 1600 Meter Run

1. Joe Sapone, Holy Innocents', 4:04.27#
2. Alex Arrambide, East Forsyth, 4:06.16
3. Gabriel Best, Whitewater, 4:18.03
4. Joseph Jacquot, Westminster, 4:18.41

## 400 Meter Dash

1. Therrian Alexander III, SW DeKalb, 46.84
2. William Gituku, Westminster, 47.12
3. Xzaviah Taylor, Southwest DeKalb, 47.24
4. Braeden Ofosu-Kwarteng, Whitewater, 47.27

## 100 Meter Dash

1. Ali Dargan, Miller Grove, 10.36
2. Jace Coleman, Stephenson, 10.44
3. Lassale Hewlett, Hampton, 10.50
4. Cassie Scott, Woodland-Henry, 10.60

## 110 Meter Hurdles

1. Isaiah Taylor, SW DeKalb, 13.70
2. Dominiq Northington, Woodland-Hen., 14.27
3. Markel Kelly, Burke County, 14.55
4. Quan Dorsey, Cedartown, 14.59

## 800 Meter Run

1. Justin Warner, Fayette County, 1:54.18
2. Willem Mandel, Westminster, 1:54.74
3. Rohan Gazula, Westminster, 1:54.99
4. Derrick Eskridge, SW DeKalb, 1:55.27

## 200 Meter Dash

1. Ali Dargan, Miller Grove, 20.86#
2. Jace Coleman, Stephenson, 21.30
3. Curtis Coleman, Southeast Bulloch, 21.32
4. Lassale Hewlett, Hampton, 21.33

## 300 Meter Hurdles

1. Isaiah Taylor, Southwest DeKalb, 35.94#
2. Xzaviah Taylor, Southwest DeKalb, 37.78
3. Rodney Bryant, Perry, 38.72
4. Quan Dorsey, Cedartown 39.43

## 3200 Meter Run

1. Alex Arrambide, East Forsyth, 9:16.24
2. Joe Sapone, Holy Innocents', 9:19.10
3. Gabriel Best, Whitewater, 9:25.89
4. Joseph Jacquot, Westminster, 9:26.51

## 4x400 Meter Relay

1. SW DeKalb 3:10.55# (Therrian Alexander III; Isaiah Taylor; Xzaviah Taylor; Xavier Turner)
2. Fayette Co. 3:15.56 (Justin Warner; Michael Keniye; Justice Northern; Trenneddy Whatley)
3. Stephenson 3:16.42 (Steven Brown; Todd Burton; Jace Coleman; Kwabena Flowers)
4. Whitewater 3:19.94 (Ademola Adewusi; Angel Urugutia; Joe Kennedy; Braeden Ofosu-Kwarteng)

# STATE TRACK MEETS - 2023

## 4x200 Meter Relay

1. SW DeKalb 1:25.13# (Taylor Anderson; Xzaviah Taylor; Xavier Turner; Therrian Alexander III)
2. Stephenson 1:27.19 (Kwabena Flowers; Collin Seals; Markel Key; Kristopher Woodard)
3. Cedar Shoals 1:27.87 (Toby Bolton; Tumari Collins; Devin Hester; Chase Rucker)
4. Baldwin 1:29.30 (Jaylen Boone; Z'Kwon Dyous; Yauri Calixte; Sadur Salahuddin)

## Team Scores

1. Southwest DeKalb.....81
2. Starrs Mill, School.....77.5
3. Westminster School.....72.5
4. Whitewater.....36

## Class 4A GIRLS

### Discus Throw

1. Avah Morrison, Heritage-Catoosa, 130-01
2. Dayneja Atkins, Stockbridge, 125-11
3. Emily Lane, Northwest Whitfield, 122-09
4. Kayli Miller, Central-Carroll, 115-05

### High Jump

1. Zy Thompson, Griffin, 5-06.00
2. Brooke Fung Chung, Pace Academy, 5-04.00
3. Eve Taylor, North Hall, 5-02.00
3. Nafer Rapier, Baldwin, 5-02.00

### Long Jump

1. Grace Smith, Westminster, 18-07.50
2. Kelsey Chambers, Westminster, 18-06.50
3. Ryan McFadden, Westminster, 18-02.00
4. Anna Spencer, Cairo, 18-01.50

### Pole Vault

1. Madison Townsend, Westminster, 11-00.00
2. Gabby Nguyen, North Oconee, 11-00.00
3. Sadie Arnold, North Oconee, 10-06.00
4. Em Jones, Central-Carroll, 10-06.00

### Shot Put

1. MaKayla Register, West Laurens, 39-04.50
2. Dayneja Atkins, Stockbridge, 38-03.00
3. Treasure Jenkins, Bainbridge, 38-02.00
4. Onoyeme Egre, Fayette County, 38-02.00

### Triple Jump

1. Kelsey Chambers Westminster, 38-11.00
2. Ty'Kira Garrett Stephenson, 38-03.00
3. Angel Johnson Fayette County, 37-10.50
4. Bella Goode Trinity Christian, 37-06.50

### 4x800 Meter Relay

1. Pace Acad. 9:27.36# (Harriet Blaha; Zahara Bernal; Caroline Hood; Olivia Resnick)
2. North Oconee 9:33.51 (Ansleigh Prell; Ava Caldwell; Emily Smith; Laura Francis Willis)
3. Westminster 9:44.53 (Lucy Johnson; Cate Reames; Frances Munger; Palmer Walstad)
4. North Hall 9:52.61 (Abi Moore; Lily Kate Morgan; Jessie Dubnik; Clodagh O'Bryant)

### 4x100 Meter Relay

1. Druid Hills 45.74# (Jadyn Bolden; Miya Carthan; Sanaa Frederick; Sole Frederick)
2. Spalding 47.58 (Jernyla Andrews; Brandi Heard; Quitara Castlin; Mickey Fonfield)
3. Stephenson 47.73 (Marissa Munerlyn; Ty'Kira Garrett; Caseyona Hight; Maniah Powell)
4. Westover 48.43 (Taylor Singleton; Wykeria Holmes; Rayven Thurston; Madison Mitchell)

### 1600 Meter Run

1. Caroline Hood, Pace Academy, 4:53.65

2. Palmer Walstad, Westminster, 5:01.45
3. Clodagh O'Bryant, North Hall, 5:08.60
4. Ava Caldwell, North Oconee, 5:13.84

### 400 Meter Dash

1. Jadyn Bolden, Druid Hills, 55.27
2. Camille Quarterman, Westminster, 55.80
3. Sole Frederick, Druid Hills, 56.56
4. Mia Brown, Starr's Mill, 56.81

### 100 Meter Dash

1. Sanaa Frederick, Druid Hills, 11.41
2. Grace Smith, Westminster, 11.74
3. Marissa Palmer, New Hampstead, 11.83
4. Maniah Powell, Stephenson, 11.92

### 100 Meter Hurdles

1. Grace Smith, Westminster, 14.45
2. Hannah Cheek, Cherokee Bluff, 14.64
3. Alina Harris, Griffin, 14.67
4. Mattison Rowell, Woodland-Henry, 14.95

### 800 Meter Run

1. Abi Moore, North Hall, 2:15.75
2. Kendra Ivaska, Starr's Mill, 2:16.79
3. Quenteria Birts, Stockbridge, 2:19.26
4. Palmer Walstad, Westminster, 2:19.60

### 200 Meter Dash

1. Sanaa Frederick, Druid Hills, 23.39#
2. Sole Frederick, Druid Hills, 23.41
3. Nya Blocker, Bainbridge, 24.22
4. Nevaeh Lacey, Woodland-Henry, 24.77

### 300 Meter Hurdles

1. Grace Smith, Westminster, 43.16
2. Nafer Rapier, Baldwin, 44.85
3. Alina Harris, Griffin, 45.35
4. Caseyona Hight, Stephenson, 45.36

### 3200 Meter Run

1. Caroline Hood, Pace Academy, 10:51.96
2. Palmer Walstad, Westminster, 11:24.28
3. Clodagh O'Bryant, North Hall, 11:32.59
4. Harriet Blaha, Pace Academy, 11:38.92

### 4x400 Meter Relay

1. Druid Hills 3:49.85 (Sanaa Frederick; Jadyn Bolden; Sole Frederick; Miya Carthan)
2. Stockbridge 3:55.39 (Quenteria Birts; Kennedy Bryan; Liana Gladden; Kirah Copeland)
3. Griffin 3:57.34 (Alina Harris; Mirakle Hill; Makayla Toussaint; Savannah Welch)
4. Starr's Mill 3:57.88 (Mia Brown; Bella Gorman; Kendra Ivaska; Kali McQuade)

### 4x200 Meter Relay

1. Stockbridge 1:40.21# (Kirah Copeland; Monika Demps; Kennedy Bryan; Jayla Lee)
2. Westover 1:41.47 (Madison Mitchell; Lynziria Thomas; Wykeria Holmes; Taylor Singleton)
3. Stephenson 1:42.23 (Ty'Kira Garrett; Casiyaha Hight; Marissa Munerlyn; Caseyona Hight)
4. Woodland-Hn. 1:42.52 (Nevaeh Lacey; Marleah Campbell; Nadia Guyton; Ania Campbell)

### Team Scores

1. Westminster.....124
2. Druid Hills.....64
3. Pace Academy.....54
4. Stockbridge.....48

## Class 3A BOYS

### Discus Throw

1. Rickey Robbins, Monroe Area, 164-04
2. Devereaux Benoit, Liberty County 152-03

3. Dacian Davis, Monroe Area, 150-08
4. Jacere Cooper, Morgan County, 150-03

### High Jump

1. Justin Burns, Monroe, 6-06.00
2. John Hopson, Sandy Creek, 6-04.00
3. Blake Davis, Sandy Creek, 6-02.00
4. Jordan Bartleson, Hebron Christian, 6-02.00

### Long Jump

1. Sean Hughes, White County, 22-03.00
2. Tristen Toss, LaFayette, 22-00.00
3. Favion Kirkwood, Johnson-Sav., 21-06.00
4. Jakyri Jones, Monroe Area, 21-04.00

### Pole Vault

1. Owen Anderson, Hebron Christian, 15-01.00
2. Luke Samples, Hart County, 14-00.00
3. Gage Lee, Pike County, 14-00.00
4. Isaac Vanduyhoven, Liberty Co., 13-06.00

### Shot Put

1. Solomon Hall, Cedar Grove, 53-09.00
2. Kelton Smith, Carver-Columbus, 52-04.00
3. Jacere Cooper, Morgan County, 51-11.00
4. Will Kiker, Gilmer, 50-08.00

### Triple Jump

1. Dalen Penson, Sandy Creek, 45-10.00
2. Jamie Tremble, Wesleyan, 45-04.50
3. Blake Davis, Sandy Creek, 44-03.00
4. Skyler Mitchell, Carver-Columbus, 43-11.50

### 4x800 Meter Relay

1. Oconee Co. 8:10.78 (Steven Durocher; Andrew Knapp; Patterson Graham; Cooper Timberman)
2. Pike County 8:21.12 (John Barber; Andrew Edwards; Xander Potter; Luke Woerner)
3. Hart County 8:24.03 (Andrew Brezeale; Braydon Lane; Nate Harris; Luke Samples)
4. Wesleyan 8:27.69 (Christopher Izzo; Andrew Cook; Landon Jonas; Wood Moore)

### 4x100 Meter Relay

1. Carver-Col. 42.14 (Brandon Webb Jr.; Jamari Riley; Mohamed Traore; Kevin Johnson)
2. Johnson-Sav. 42.16 (Damine Smith; JaQuay Foster; Jadon Pugh; Samari Dowdy)
3. Monroe 42.53 (Tykerie Washington; Justin Burns; Johnny Cauley; Usir Bey)
4. Monroe Area 42.66 (Jakyri Jones; Malik Norman; C.J. Wilburn; Jahlun Flud)

### 1600 Meter Run

1. Cooper Timberman, Oconee County, 4:19.96
2. John Ryan, Sav. Country Day, 4:23.38
3. Wyatt Windham, Lumpkin Co., 4:24.13
4. Aaron Brodrick, Oconee County, 4:25.68

### 400 Meter Dash

1. Jamari McIvory, Savannah Christian, 48.10
2. Braden Griffin, Stephens County, 49.01
3. Kani Smith, Carver-Atlanta, 49.28
4. Geimere Latimer, Sandy Creek, 49.63

### 100 Meter Dash

1. Samari Dowdy, Johnson-Savannah, 10.72
2. Darrian Burks, Ridgeland, 10.78
3. Joseph Slaughter, Cedar Grove, 10.79
4. C.J. Wilburn, Monroe Area, 10.86

### 110 Meter Hurdles

1. Mohamed Diaby, Carver-Columbus, 13.81
2. Dalen Penson, Sandy Creek, 14.21
3. Carlos Barlow, Jackson, 14.59
4. Gandor Bah, Sandy Creek, 15.00

# STATE TRACK MEETS - 2023

## 800 Meter Run

1. Cooper Timberman, Oconee County, 1:54.78
2. John Ryan, Sav. Country Day, 1:57.25
3. Nehemiah Horton, Richmond Acad., 1:57.52
4. Wyatt Windham, Lumpkin County, 1:57.87

## 200 Meter Dash

1. Jamari McIvory, Savannah Christian, 21.65
2. C.J. Wilburn, Monroe Area, 21.96
3. Cam Wilson, White County, 22.12
4. Braden Griffin, Stephens Co., 22.14

## 300 Meter Hurdles

1. Josh Jones, Morgan County, 38.33
2. Kyshon Kenney, Sandy Creek, 39.51
3. Judah Hobb, Oconee County, 39.52
4. Mohamed Diaby, Carver-Columbus, 40.32

## 3200 Meter Run

1. Aaron Brodrick, Oconee County, 9:33.63
2. Wood Moore, Wesleyan, 9:41.96
3. Cooper Timberman, Oconee County, 9:51.15
4. Wyatt Windham, Lumpkin Co., 9:58.29

## 4x400 Meter Relay

1. Monroe 3:20.30 (Usir Bey; Sedrick Roundtree; Johnny Cauley; Tykerie Washington)
2. Sandy Cr. 3:20.45 (Braylin Blackburn; Geimere Latimer; Zavion Green; Kyshon Kenney)
3. White County 3:24.65 (Cam Wilson; Cayson Duval; Jackson Jarvis; Elijah Nelson)
4. Savannah Christian 3:26.58 (Gary Scott; Jaden Ward; Witt Hayes; Jamari McIvory)

## 4x200 Meter Relay

1. Sandy Cr. 1:27.44# (Zavion Green; Geimere Latimer; Kyshon Kenney; Cameron Watts)
2. Monroe 1:27.96 (Justin Burns; Tykerie Washington; Johnny Cauley; Usir Bey)
3. Liberty Co. 1:28.31 (Markel Adside; James Summersett; Keyshawn Hollis; Jamar Joseph)
4. Carver-Col. 1:28.99 (Brandon Webb; Isaiah Jenkins; Kevin Johnson; Mohamed Traore)

## Team Scores

- |                         |    |
|-------------------------|----|
| 1. Sandy Creek.....     | 86 |
| 2. Oconee County.....   | 68 |
| 3. Carver-Columbus..... | 54 |
| 4. Monroe.....          | 40 |

## Class 3A GIRLS

### Discus Throw

1. Kayla Lane, Hebron Christian, 123-01
2. Ariyana Johnson, Sandy Creek, 119-04
3. Saniya Heard, Franklin County, 116-08
4. Qua'Nesha Brown, Mary Persons, 114-04

### High Jump

1. Marley Derringer, Bremen, 5-08.00
2. Maggie Byrd, Savannah Christian, 5-04.00
3. Taylor McCormick, Gilmer, 5-04.00
4. Claire Beckman, White County, 5-02.00
4. Aliya McBryde, Adairsville, 5-02.00

### Long Jump

1. Jadyn Singleton, Savannah Christ., 18-04.75
2. Morgan Graham, Monroe Area, 18-01.50
3. Valasha Carter, Hart County, 17-06.50
4. Sky White, Sandy Creek, 17-04.00

### Pole Vault

1. Amelia Johnson, Hart County, 13-00.00#
2. Noelle Hambrick, Bremen, 12-06.00
3. Ella Blair, White County, 11-06.00
4. Libby Jackson, Hebron Christian, 10-06.00

## Shot Put

1. Kendra Dye, White County, 43-09.00
2. Jadan Dean, Pickens, 39-03.00
3. Hoake Mazzawi, Hebron Christian 38-07.00
4. Annabelle Langley, Bremen, 37-09.50

## Triple Jump

1. Ryan Lewis, Sandy Creek, 40-00.00
2. Alyvia Matthews, Bremen, 37-09.50
3. Anaja Lucear, Mary Persons, 37-02.00
4. Kiyami Zimmerman, Monroe Area, 37-01.00

## 4x800 Meter Relay

1. Wesleyan 9:49.57 (Julie Anne Bush; Abigail Glover; Kyra Brubaker; Anne McSweeney)
2. Dawson Co. 10:05.14 (Jules Phillips; Anna LeCave; Emily Kurtz; Katie Gloeckner)
3. Pickens 10:05.73 (Bekah Wise; Kaela Kearney; Brylee Deering; Eleina Bryant)
4. White Co. 10:22.44 (Emma Lightsey; Emma Windham; Reese Vandegriff; Nealeigh Broadwell)

## 4x100 Meter Relay

1. Sandy Creek 47.03 (Malia Watts; Ryan Lewis; Isis Symone Grant; Bobbi Olive)
2. Carver-Atlanta 47.93 (DeMya Gates; Itavia McCord; Tarrianna Jackson; Amiyah Floyd)
3. Peach Co. 48.19 (Tamyra Blackmon; Lilian Wright; Tamori Hollingshed; Azaria Burr-Major)
4. Monroe Area 48.39 (Ajiuna Upshaw; Alana Jones; Vashondra Sandifer; Morgan Graham)

## 1600 Meter Run

1. Anne McSweeney, Wesleyan 5:15.71
2. Julie Anne Bush, Wesleyan 5:18.83
3. Emma Champer, Oconee County, 5:20.27
4. Eva Murphy, Wesleyan, 5:24.44

## 400 Meter Dash

1. Isis Symone Grant, Sandy Creek, 55.55
2. Kaitlyn Williams, Monroe, 57.50
3. Haely Grant, Calvary Day, 57.70
4. Saniyah Burchfield, Douglass, 58.13

## 100 Meter Dash

1. Bobbi Olive, Sandy Creek, 11.88
2. Ryan Lewis, Sandy Creek, 11.89
3. Tarrianna Jackson, Carver-Atlanta, 12.05
4. Tamyra Blackmon, Peach Co., 12.10

## 100 Meter Hurdles

1. Brooke Jordan, Cross Creek, 14.59
2. Kiyami Zimmerman, Monroe Area, 14.97
3. Alexis Knox, Franklin County, 14.99
4. Ava Moon, Oconee County, 15.17

## 800 Meter Run

1. Isis Symone Grant, Sandy Creek, 2:10.09#
2. Anne McSweeney, Wesleyan, 2:18.53
3. Anna LeCave, Dawson County, 2:23.10
4. Eve Craig, Monroe, 2:24.75

## 200 Meter Dash

1. Bobbi Olive, Sandy Creek, 24.28
2. Ryan Lewis, Sandy Creek, 24.47
3. Saniyah Hailey, Hepzibah, 24.89
4. Marianna Wright, Monroe, 24.94

## 300 Meter Hurdles

1. Marianna Wright, Monroe, 41.63#
2. Brooke Jordan, Cross Creek, 44.13
3. Ava Moon, Oconee County, 45.37
4. Kiyami Zimmerman, Monroe Area, 45.59

## 3200 Meter Run

1. Emma Champer, Oconee County, 11:37.40
2. Eva Murphy, Wesleyan, 11:45.30
3. Julie Anne Bush, Wesleyan 11:55.00
4. Megan Hightower, Franklin Co., 11:58.64

## 4x400 Meter Relay

1. Monroe 3:52.57 (Eve Craig; Jurdyn Johnson; Kaitlyn Williams; Marianna Wright)
2. Sandy Creek 4:01.98 (Bobbi Olive; Noelle Boyd; Empress Malone; Isis Symone Grant)
3. Monroe Area 4:07.50 (Kiyami Zimmerman; Addalyn Perkins; Samara Hill; Jakeria Jackson)
4. Bremen 4:07.64 (Alyvia Matthews; Kathryn Christian; Abby Waldrop; Amanda Rhinehart)

## 4x200 Meter Relay

1. Monroe 1:41.74# (Eve Craig; Marianna Wright; Kaitlyn Williams; Jurdyn Johnson)
2. Carver-Atlanta 1:42.37 (Amiyah Floyd; Nyla Thomas; DeMya Gates; Itavia McCord)
3. Monroe Area 1:42.87 (Vashondra Sandifer; Morgan Graham; Alana Jones; Adaisha Upshaw)
4. Peach Co. 1:43.71 (Azaria Burr-Major; Tamyra Blackmon; Tamori Hollingshed; Lilian Wright)

## Team Scores

- |                     |      |
|---------------------|------|
| 1. Sandy Creek..... | 104  |
| 2. Wesleyan.....    | 58.5 |
| 3. Monroe.....      | 51   |
| 4. Monroe Area..... | 48   |

## Class 2A BOYS

### Discus Throw

1. Chester, DJ, ELCA, 174-10
2. Wilson, Bryman, Cook, 159-08
3. Heard, Jeremias, Model, 158-06
4. Nobles, Brock, Toombs County, 153-00

### High Jump

1. Saunders, DeVein, Brantley County, 6-04.00
2. Taylor, Willie, Butler, 6-04.00
2. Fletcher, Gavin, Toombs County, 6-04.00
4. Fulton, D'Ontae, Worth County, 6-04.00

### Long Jump

1. Hunt, Xayden, Jordan, 22-04.50
2. Evans, Jackson, Walker, 22-01.00
3. Davis, Aaron, ACE Charter, 22-00.00
4. Mayner, Jeremiah, Tattnall County, 21-09.25

### Pole Vault

1. Davenport, Corbin, Fannin County, 13-06.00
2. Stevenson, Tyler, Fannin County, 13-06.00
3. Lucas, Hoke, Athens Academy, 13-00.00
4. Edge, Collin, Athens Academy, 12-00.00

### Shot Put

1. Chester, DJ, ELCA, 58-08.00
2. Barge, Darius, Jeff Davis, 55-10.00
3. Heard, Jeremias, Model, 53-03.00
4. Magby, Raylene, South Atlanta, 52-09.00

### Triple Jump

1. Beasley, Brandon, Vidalia, 46-04.00
2. Josey-Durham, Caleb, Sumter Co., 46-02.00
3. Olabosinde, Oluwatosin, Elite Scholars, 45-03.50
4. Bennett, Kenyatta, Drew Charter, 44-06.00

## 4x800 Meter Relay

1. Athens Ac. 8:10.22 (Scruggs, Jackson; Marley, Ryland; Dillon, Robbie; DeLoach, Will)
2. Landmark 8:18.41 (Grimes, Garrison; Rivers, Righton; Zamora, Thomas; Costen, London)

# STATE TRACK MEETS - 2023

3. Banks Co. 8:19.76 (Davis, Pepper; Loggins, Troy; Bowman, Mitchell; Stephens, Chase)
4. Model 8:27.06 (Schabort, Simon; Moon, Eli; Goggans, Thomas; Fincher, Owen)

## 4x100 Meter Relay

1. Drew Charter 41.31# (Meggett, Isarel; White Jr., Eric; Adams, Simeon; Price, Taj)
2. ELCA 42.01 (Holley, Jacque; Banks, Josh; Hood, Colton; Gordon, Miles)
3. Landmark 42.30 (Tukes, Ian; Campbell, Jaxson; Smith, Isaac; Ward, Evan)
4. Pierce Co. 42.40 (Hartzog, Dexter; White, Jaquez; Guyton, Jimarion; Drew, Joe)

## 1600 Meter Run

1. Schabort, Simon, Model, 4:13.66
2. Scruggs, Jackson, Athens Academy, 4:22.68
3. DeLoach, Will, Athens Academy, 4:30.57
4. Loggins, Troy, Banks County, 4:31.75

## 400 Meter Dash

1. Costen, London, Landmark Christian, 47.94
2. Hickcox, Camden, Appling County, 48.94
3. White Jr., Eric, Drew Charter, 49.28
4. Lawson, Da'tavion, Fitzgerald 49.66

## 100 Meter Dash

1. Warren, Kameran, Washington, 10.75
2. McGee, Austin, Athens Academy, 10.80
3. Jolly, Daniel, Model, 10.83
4. Magwood, Lakail, Fitzgerald, 10.99

## 110 Meter Hurdles

1. Berry, Nahvie, Vidalia, 14.93
2. Willis, Grayson, Fannin County, 15.07
3. Webb, Zi'Quan, Spencer, 15.34
4. Simpkins, Altravion, Josey 15.37

## 800 Meter Run

1. Costen, London, Landmark Christ., 1:55.17
2. Schabort, Simon, Model, 1:55.28
3. DeLoach, Will, Athens Academy, 1:58.15
4. Scruggs, Jackson, Athens Academy, 1:58.31

## 200 Meter Dash

1. Holley, Jacque, ELCA, 21.64
2. Hickcox, Camden, Appling County, 21.85
3. White Jr., Eric, Drew Charter, 21.98
4. Adams, Simeon, Drew Charter, 22.16

## 300 Meter Hurdles

1. White, Jaquez, Pierce County, 37.91
2. Tukes, Ian, Landmark Christian, 39.41
3. Rousseau, Jamari, Landmark Christ., 39.65
4. McCrary, Lanear, Rockmart, 40.93

## 3200 Meter Run

1. Schabort, Simon, Model, 9:39.38
2. Scruggs, Jackson, Athens Academy, 9:46.75
3. Davis, Pepper, Banks County, 9:53.26
4. Prater, Zechariah, Fannin County, 9:58.26

## 4x400 Meter Relay

1. Appling Co. 3:18.22 (Solomon, William; Moore, Tre'Shawn; McMillan, Jermaine; Hickcox, Camden)
2. Landmark 3:19.34 (Tukes, Ian; Rivers, Righton; Costen, London; Rousseau, Jamari)
3. Drew Charter 3:23.55 (Meggett, Isarel; Paxton, Khalil; White Jr., Eric; Hodges, Melvin)
4. B.E.S.T. Academy 3:26.78 (Johnson, John; Norman-Harris, Khlyen; Salahadyn, Rasheed; Scott Jr, Kevin)

## 4x200 Meter Relay

1. Washington 1:27.97# (Warren, Quindarius; Wiley, KeShawn; Warren, Kameran; Turner, Jordan)
2. Appling Co. 1:28.04 (Solomon, William; McMillan, Jermaine; Ryals, Kemoni; Hickcox, Camden)
3. Vidalia 1:28.76 (Barron, Antonio; Beasley, Brandon; McClendon, AJ; Jacobs, Tyrann)
4. Landmark 1:29.63 (Smith, Isaac; Rousseau, Jamari; Hamilton, Skylar; Ward, Evan)

## Team Scores

1. Athens Academy.....89.5
2. Landmark Christian.....86.5
3. Model.....56
4. Fannin County.....42

## Class 2A GIRLS

### Discus Throw

1. Speed, Shelby, Banks County, 153-01#
2. McCord, Kayla, Josey, 122-01
3. Babbitt, Veronika, Athens Academy, 121-10
4. Campuzano, Meredith, Gordon Cent., 115-03

### High Jump

1. Collins, Josie, Athens Academy, 5-04.00
2. Scott, Janiya, Thomson, 5-04.00
3. Clemons, Teandra, Appling County, 5-00.00
4. McCray, Caziaha, Elite Scholars, 4-10.00

### Long Jump

1. Chadwick, Ellison, Providence Chr. 19-05.25
2. Clemons, Teandra, Appling Co., 17-11.50
3. Simmons, Jayla, Elite Scholars, 17-04.25
4. Robinson, Keamaura, Columbia, 16-11.25

### Pole Vault

1. Scruggs, Sophie, Pierce County, 11-07.00
2. Parlotto, Aurora, Walker, 10-06.00
3. Orr, Reagan, Model, 9-06.00
4. Peavey, Mallory, Fitzgerald, 8-00.00
4. Yelegoiyee, Tracy, Towers, 8-00.00
4. Farmer, Trinity, Rockmart, 8-00.00
4. Thorne, Sarah Evans, Landmark, 8-00.00

### Shot Put

1. Speed, Shelby, Banks County, 43-07.00
2. Babbitt, Veronika, Athens Acad., 41-02.00
3. Lewis, Shantie, Jeff Davis, 37-02.50
4. McCord, Kayla, Josey, 35-10.00

### Triple Jump

1. Edwards, Nashari, Towers, 35-02.00
2. Rooks, India, Appling County, 35-01.50
3. Jordan, Iyanna, Spencer, 34-11.00
4. Lawrence, Gabriella, Redan, 34-06.50

### 4x800 Meter Relay

1. Athens Acad. 9:59.65 (Davis, Maya; Dillon, Ella; Harrison, Sarah; Smith, Molly)
2. Fannin Co. 10:11.52 (Acker, Ava; Holloway, Lindsey; Holloway, Carlee; Sams, Karli)
3. Landmark 10:20.16 (Thorne, Sarah Evans; Guerard, Turner; Wilson, Charlotte; Brown, Shari)
4. Union Co. 10:28.54 (Adams, Ellie; Hunter, Lola; Kazmierzak, Hannah; Hyatt, Noel)

### 4x100 Meter Relay

1. Landmark 47.74 (Carter, Naia; Chachere, Cristiana; Allrich, MiAngel; Gullatte, Taylor)
2. Appling Co. 48.26 (Holmes, Jasmine; Mitchell, Perry; Clemons, Teandra; Cray, Cadence)
3. Drew Charter 49.13 (White, Lelahbrooke; Robinson, Nivayah; Roberts, Jakaylah; Cooper, Madeline)

4. Fitzgerald 49.54 (Burch, E'Laundra; Hill, A'Mya; Mack, Travianna; Smith, Saniya)

## 1600 Meter Run

1. Davis, Maya, Athens Academy, 5:04.73
2. Brown, Shari, Landmark Christian, 5:17.24
3. Harrison, Sarah, Athens Academy, 5:20.45
4. Holloway, Lindsey, Fannin County, 5:22.10

## 400 Meter Dash

1. Campbell, Malia, Landmark Christian, 55.17
2. Chadwick, Ellison, Providence Christ., 57.12
3. Pittman, Antonia, East Jackson, 57.43
4. Anthony, Kara, ELCA, 58.57

## 100 Meter Dash

1. Cooper, Madeline, Drew Charter, 11.71#
2. Gullatte, Taylor, Landmark Christian, 11.79
3. Cray, Cadence, Appling County, 12.25
4. Harrell, Autumn, ELCA, 12.26

## 100 Meter Hurdles

1. Cooper, Madeline, Drew Charter, 13.93#
2. Edwards, Nashari, Towers, 15.65
3. Howard, Za'Liah, Worth County, 16.08
4. Hewlin, Gabi, ELCA, 16.13

## 800 Meter Run

1. Olson, Lyric, Savannah Arts, 2:09.60
2. Davis, Maya, Athens Academy, 2:13.33
3. Brown, Shari, Landmark Christian, 2:20.24
4. Sutton, Sydney, Model, 2:22.74

## 200 Meter Dash

1. Gullatte, Taylor, Landmark Christian, 24.04
2. Cooper, Madeline, Drew Charter, 24.88
3. Campbell, Malia, Landmark Christian, 24.90
4. Simmons, Jayla, Elite Scholars, 25.13

## 300 Meter Hurdles

1. Hernandez, Laisha, Jeff Davis, 44.92
2. Harris, Carmen, Laney, 47.76
3. Mallory, Makenzie, Washington Co., 48.39
4. Edwards, Nashari, Towers, 48.69

## 3200 Meter Run

1. Coffey, Ava, Savannah Arts, 11:38.15
2. Holloway, Lindsey, Fannin County, 11:45.24
3. Shaylor, Elizabeth, N. Cobb Christ., 11:57.55
4. Davis, Maya, Athens Academy, 11:57.81

## 4x400 Meter Relay

1. Landmark 3:52.24 (Brown, Shari; Gullatte, Taylor; Campbell, Malia)
2. Model 4:06.35 (Sutton, Sydney; Samples, Javia; Long, Natalie; Allmon, Claire)
3. Elite Scholars 4:10.85 (Johnson, Genesis; Largent, Sanieya; Simmons, Jayla; Akinwande, Michelle)
4. E. Jackson 4:12.35 (Weaver, Alivia; Hanna, Vayda; Rakestraw, Destiny; Pittman, Antonia)

## 4x200 Meter Relay

1. Appling Co. 1:41.37# (Holmes, Jasmine; Mitchell, Perry; Clemons, Teandra; Cray, Cadence)
2. Landmark 1:41.41 (Carter, Naia; Chachere, Cristiana; Allrich, MiAngel; Campbell, Malia)
3. ELCA 1:44.19 (Harrell, Autumn; Reid, Chelsea; Anthony, Kara; Mayweather, Cerrigan)
4. Mt. Paran 1:44.37 (Abernathy, Kyndal; Perry, Maya; Lacivita, Ella Grace; Stubbs, Alexis)

## Team Scores

1. Landmark Christian.....86.5
2. Athens Academy.....83



# STATE TRACK MEETS - 2023

3. Applying County.....51
4. Drew Charter.....34

## Class A, Division 1 BOYS

### High Jump

1. Carruthers, Jacob, Barrow Arts, 6-08.00
2. Goodwyn, Willie, Rabun County, 6-04.00
3. Jones, Demello, Swainsboro, 6-04.00
4. Nelson, Clayton, Lamar County, 6-02.00

### Pole Vault

1. Vanderpool, Brenden, Whitefield Ac., 14-06.00
2. Byram, Clarke, Athens Christian, 14-06.00
3. Usher, Wesley, Commerce, 13-06.00
4. Burden, Rashaud, Heard County, 13-00.00

### Long Jump

1. Carter, Makoel, Mt. Pisgah, 22-07.00
2. Simmons, Warren Winston, Mt. Pisgah, 21-08.25
3. Glenn, Jace, Temple, 21-04.50
4. Adams, Ty, Swainsboro, 21-03.25

### Triple Jump

1. Green, LJ, Heard County, 47-04.75
2. Adams, Ty, Swainsboro, 45-11.00
3. Jones, Demello, Swainsboro, 45-03.00
4. Fleming, Michael, Oglethorpe Co., 45-01.50

### Discus Throw

1. Dardy, Ramonte, Dublin, 156-00
2. Bonds, KB, Oglethorpe County, 154-00
3. Ketch, Sam, Tallulah Falls, 151-00
4. Phillips, Da'rius, Swainsboro, 148-00

### Shot Put

1. Gammage, Gus, Darlington, 54-05.00
2. Garrett, Christian, Prince Avenue, 48-04.00
3. Tucker, Max, Mt. Pisgah, 47-07.00
4. Johnson, Nasir, Dublin, 47-06.50

### 4x800 Meter Relay

1. Athens Chr. 8:05.43# (Brink, Johann; Vaughn, Eli; Smith, Nathan; Wilkins, Thrasher)
2. Mt. Vernon 8:07.73 (Jolly, Curran; Flynn, Haris; Knight, James; Maher, Collin)
3. Darlington 8:15.80 (Natarella, Anthony; Cross, Grant; Parsa, Hayes; Glass, Ryan)
4. Bleckley Co. 8:15.98 (Camp, Logan; Darsey, Caleb; Churchwell, Luke; Dominy, Briggs)

### 110 Meter Hurdles

1. Fleming, Michael, Oglethorpe County, 14.14
2. Ates, Daevonta, Bleckley County, 14.53
3. Cook, Zayden, Chattooga, 14.54
4. Byram, Clarke, Athens Christian, 15.67

### 100 Meter Dash

1. Jones, Demello, Swainsboro, 10.97
2. Brown, Qindarius, Swainsboro, 11.04
3. Whidby, Kaidon, Jasper County, 11.05
4. Tophia, Nagari, Mt. Vernon, 11.14

### 4x200 Meter Relay

1. Prince Avenue 1:28.88 (Darling, Luke; Bennett, Trey; Bennett, Robbie; Britt, Joshua)
2. Heard Co. 1:29.46 (Williams, Messiah; Nelson, Marquavious; Green, LJ; Banks, Jack)
3. Elbert Co. 1:29.93 (Burton, Timorris; Dowdy, Stanley; Barnett, Jacari; Davis, Isiah)
4. Commerce 1:30.97 (Morris, Jackson; Fields, Josh; Huff, Jacari; Usher, Wesley)

### 1600 Meter Run

1. Churchwell, Luke, Bleckley County, 4:17.98
2. Smith, Nathan, Athens Christian 4:22.79
3. Flynn, Haris, Mt. Vernon, 4:30.60

4. Lynch, Michael, Mt. Pisgah, 4:31.59

### 4x100 Meter Relay

1. Oglethorpe Co. 42.48 (Lumpkin, Jaelin; Hood, Elijah; Fleming, Michael; Sampson, Will)
2. Swainsboro 42.53 (Adams, Ty; Brown, Qindarius; Williams, Jordan; Jones, Demello)
3. Elbert Co. 42.69 (Jones, Ty'Rikis; Dowdy, Stanley; Davis, Isiah; Burton, Timorris)
4. Jasper Co. 43.06 (Cotterell, Josiah; Banks, Tyler; Williams, Randy; Whidby, Kaidon)

### 400 Meter Dash

1. Tucker, Max, Mt. Pisgah, 48.32
2. Carruthers, Jacob, Barrow Arts, 48.48
3. Wommack, Joseph, Darlington, 49.84
4. Britt, Joshua, Prince Avenue, 50.21

### 300 Meter Hurdles

1. Anderson, Nathan, Woodville-Tomp., 39.11
2. Anderson, Nick, Mt. Pisgah, 39.17
3. Reeves, Tayshawn, Jasper County, 40.16
4. Anderson, Jace, Dade County, 40.71

### 800 Meter Run

1. Churchwell, Luke, Bleckley County, 1:56.44
2. Wilkins, Thrasher, Athens Christian 1:59.01
3. Flynn, Haris, Mt. Vernon 1:59.45
4. Jolly, Curran, Mt. Vernon 2:01.03

### 200 Meter Dash

1. Stroizer, Branden, St. Francis, 21.92
2. Huff, Jacari, Commerce, 22.28
3. Carruthers, Jacob, Barrow Arts, 22.30
4. Sampson, Will, Oglethorpe County, 22.57

### 3200 Meter Run

1. Churchwell, Luke, Bleckley County, 9:28.86
2. Smith, Nathan, Athens Christian 9:44.49
3. Lynch, Michael, Mt. Pisgah, 9:54.72
4. Darsey, Caleb, Bleckley County, 9:56.29

### 4x400 Meter Relay

1. Prince Ave. 3:24.71 (Darling, Luke; Bennett, Trey; Bennett, Robbie; Britt, Joshua)
2. Mt. Vernon 3:25.10 (Tophia, Nagari; Flynn, Haris; Jolly, Curran; Maher, Collin)
3. Mt. Pisgah 3:26.32 (Anderson, Nick; Carter, Makoel; Tucker, Max; Medebem, Alexander)
4. Darlington 3:26.90 (Wommack, Joseph; Glass, Ryan; Natarella, Anthony; Lignell, Link)

### Team Scores

1. Mount Pisgah.....70
2. Athens Christian.....60
3. Swainsboro.....59
4. Bleckley County.....54

## Class A, Division 1 GIRLS

### High Jump

1. Henderson, Kenzie, Oglethorpe Co., 5-04.00
2. Umble, Haely, Elbert County, 5-02.00
3. Prince, Savannah, Athens Christian, 5-00.00
4. Hammel, Amaya, Heard County, 5-00.00

### Pole Vault

1. Carlin, Adair, Galloway, 12-01.00
2. Thomason, Camden, Commerce, 10-00.00
3. Smith, McKinley, Athens Christian, 9-06.00
4. Crockett, Kallee, Heard County, 9-06.00

### Long Jump

1. Goddard, Denim, Oglethorpe Co., 18-03.25
2. Childress, Madison, Mt. Pisgah, 18-01.00
3. Simmons, Savannah, Mt. Pisgah, 17-06.00
4. Collins, Jayla, Commerce, 16-08.00

### Triple Jump

1. Goddard, Denim, Oglethorpe Co., 38-02.50
2. Lavant, Trinity, Claxton, 36-06.25
3. Childress, Madison, Mt. Pisgah, 36-02.25
4. Moon, Termarria, Elbert County, 35-02.00

### Discus Throw

1. Glaze, Marika, Elbert County, 121-08
2. Jordan, Jayda, Claxton, 111-04
3. Bell, Marai, Mount Bethel, 107-05
4. Denney, Maddie, Heard County, 107-04

### Shot Put

1. Finnegan, Callaghan, Paideia, 37-04.50
2. Harris, Journi, Lamar County, 36-02.50
3. Denney, Maddie, Heard County, 35-08.00
4. Boykin, Jayden, Heard County, 35-08.00

### 4x800 Meter Relay

1. Bleckley Co. 9:44.83 (Lynch, Clair; Kitchens, Lauren; Crosby, Tristen; Gibbs, Ella)
2. Armuchee 10:00.71 (Fellows, Grace; Green, Shelby; Kimple, Marissa; Thacker, Sophie)
3. Paideia 10:18.63 (Walter, Megan; Struby, Caroline; Elkinson, Sisi; Hales, Kathryn)
4. Athens Chr. 10:18.86 (Moore, Ansley; Smith, Millie; Vaughn, Josi; Smith, McKinley)

### 100 Meter Hurdles

1. Reynolds, Kennedy, Mt. Vernon, 15.16
2. Nasieku, Natania, Mt. Pisgah, 15.92
3. Ellis, Ma'Kaya, Athens Christian, 15.99
4. James, A'Shayla, Temple, 16.11

### 100 Meter Dash

1. Vandagriff, Audrey, Prince Avenue, 12.13
2. Childress, Madison, Mt. Pisgah, 12.37
3. Jackson, Olivia, Screven County, 12.43
4. Simmons, Kiera, Athens Christian, 12.57

### 4x200 Meter Relay

1. Dublin 1:43.35 (Nesbitt, Caitlyn; Lovett, Azoria; Jordan, Karmyn; Diallo, Tahara)
2. Prince Avenue 1:46.80 (Lucas, Dachel; Washington, Aidan; Ross, Maggie; Vandagriff, Audrey)
3. Lamar Co. 1:47.38 (Foster, Shakiria; Smith, Samiya; Flewellen, Armani; Barron, Aniya)
4. Atlanta Inter. 1:47.57 (Starks, Abel; Mathiot, Pauline; Starks, Abigail; Hackett, Naomi)

### 1600 Meter Run

1. Gibbs, Ella, Bleckley County, 5:00.36
2. Kimple, Marissa, Armuchee, 5:09.47
3. Moore, Ansley, Athens Christian, 5:12.06
4. Green, Shelby, Armuchee, 5:16.48

### 4x100 Meter Relay

1. Dublin 49.54 (Nesbitt, Caitlyn; Lovett, Azoria; Jordan, Karmyn; Lewis, Derricka)
2. Mt. Pisgah 49.54 (Yi, Keira; Simmons, Savannah; Childress, Madison; Nasieku, Natania)
3. Woodville-Tompkins 49.93 (Sanders, Deriyah; Gaither, Jasmine; Simmons, Zoey; Brown, Ava)
4. Prince Avenue 50.13 (Vandagriff, Audrey; Ross, Maggie; Lucas, Dachel; Washington, Aidan)

### 400 Meter Dash

1. Hyman, Jada, Social Circle, 57.68
2. Tobler, JaKara, Jasper County, 58.41
3. Shirley, Julianne, Tallulah Falls 59.75
4. Diallo, Tahara, Dublin, 1:00.60

# STATE TRACK MEETS - 2023

## 300 Meter Hurdles

1. Reynolds, Kennedy, Mt. Vernon, 44.02
2. Hackett, Naomi, Atlanta International, 45.14
3. James, A'Shayla, Temple, 45.24
4. Henderson, Kenzie, Oglethorpe Co., 46.53

## 800 Meter Run

1. Moore, Ansley, Athens Christian, 2:14.96
2. Gibbs, Ella, Bleckley County, 2:17.36
3. Green, Shelby, Armuchee, 2:22.80
4. Crosby, Tristen, Bleckley County, 2:23.24

## 200 Meter Dash

1. Vandagriff, Audrey, Prince Avenue, 24.98
2. Jackson, Olivia, Screven County, 25.25
3. Hyman, Jada, Social Circle, 25.33
4. Simmons, Kiera, Athens Christian, 25.65

## 3200 Meter Run

1. Gibbs, Ella, Bleckley County, 11:03.19
2. Kimple, Marissa, Armuchee, 11:25.79
3. Moore, Ansley, Athens Christian, 11:43.88
4. Cook, Sophia, Coosa, 11:47.30

## 4x400 Meter Relay

1. Tallulah Falls 4:07.70 (Prince, Dani; Rueda Alvarez, Sofia; Mitchell, Molly; Shirley, Julianne)
2. Commerce 4:12.11 (Adams, Ava; Bell, Paden; Tolbert, Ivy; Vazquez, Ermay)
3. Dublin 4:13.48 (Lewis, Derricka; Lovett, Azoria; Diallo, Tahara; Hogan, Jacely)
4. Atlanta Inter. 4:13.86 (Glass, Lillian; Starks, Abigail; Mathiot, Pauline; Hackett, Naomi)

## Team Scores

- |                           |    |
|---------------------------|----|
| 1. Athens Christian.....  | 62 |
| 2. Oglethorpe County..... | 56 |
| 3. Mount Pisgah.....      | 52 |
| 4. Bleckley County.....   | 51 |

### Class A, Division 2 BOYS

#### Discus Throw

1. Frank Anderson, Aquinas, 149-09
2. Dennis Thomas, Warren County, 140-07
3. Landon Young, Portal, 135-11
4. KJ Cooper, Mitchell County, 134-06

#### High Jump

1. Daryus Bryant, Manchester, 6-04.00
2. MJ Quarterman, McIntosh Co. Acad., 6-04.00
3. Kahari Bogan, Terrell County, 6-02.00
4. Malachi Ackles, Mt. Zion-Carroll, 6-02.00

#### Long Jump

1. Ahmad Carter, Montgomery Co., 21-11.50
2. Clinton Jackson, Schley County, 20-11.00
3. Dawson Lee, Hancock Central, 20-09.75
4. Jamun Coglin, Montgomery Co., 20-07.25

#### Pole Vault

1. Levi Johnson, Schley County, 13-03.00
2. Declan Ekkel, Schley County, 11-00.00
3. Robert Beal, Baconton Charter, 10-06.00
4. Matthew Nguyen, Schley County, 10-00.00

#### Shot Put

1. Tre Turner, Lincoln County, 48-04.00
2. Dontavious Johnson, Mitchell Co., 47-01.00
3. Trey Miller, McIntosh Co. Acad., 46-02.00
4. Dayshaun Copeland, Greene Co., 45-09.25

#### Triple Jump

1. Clinton Jackson, Schley County, 44-03.75
2. MJ Quarterman, McIntosh Co. Acad., 44-03.50
3. Dawson Lee, Hancock Central 44-00.50

4. MJ Mincey, Telfair County, 42-11.25

## 4x100 Meter Relay

1. Marion Co. 43.21 (Myles Jordan-King; Zariyon Barkley; Greg Harris; Keyshawn Blackshear)
2. Terrell Co. 43.86 (Kelbron Green; Kahari Bogan; Tyriss Vickerson; Chavius Jones)
3. McIntosh Co. 44.00 (Reggie Stevens; Lorinzo Reed; DeMarion McNear; Jaylan Dallas)
4. Hawkinsville 44.07 (Terry Wright; Jaiden Collins; Nelson Singletary; Zernard Smith)

## 4x100 Meter Relay

1. Greene Co. 43.68 (Doremus Alexander; Jaden Dorsey; Justin Hill; Arkiyus Wright)
2. Marion Co. 43.84 (Myles Jordan-King; Zariyon Barkley; Greg Harris; Keyshawn Blackshear)
3. Terrell Co. 43.87 (Kelbron Green; Kahari Bogan; Tyriss Vickerson; Chavius Jones)
4. Lincoln Co. 43.90 (Semaj Jenkins; Kelby Glaze; Trey Huff; Mekhi Wade)

## 1600 Meter Run

1. Julian Council, Georgia Military, 4:45.91
2. Terrell Mathis Jr., Mitchell County, 4:55.74
3. Ian Biedermann, Furlow Charter, 4:58.74
4. Edwin Gonzalez, Furlow Charter, 4:59.24

## 400 Meter Dash

1. Jeremy Bell, Clinch County, 50.70
2. Jordyn Patterson, Montgomery Co., 51.16
3. Kasen Evans, Portal, 52.10
4. Arkiyus Wright, Greene County, 52.11

## 100 Meter Dash

1. JP Powell, Miller County, 10.97
2. Quincy Edwards, Calhoun County, 11.02
3. Sencar Marks, Wheeler County, 11.22
4. Carlos Randall, Mt. Zion-Carroll, 11.25

## 110 Meter Hurdles

1. Jaylen Brown, Chattahoochee Co., 15.11
2. Jordan Coney, Treutlen, 15.12
3. Jaris Moye, Jenkins Co., 15.41
4. Jordan Acord, Mt. Zion-Carroll, 15.71

## 800 Meter Run

1. Jamarion Henderson, Montgomery Co., 2:05.50
2. Roland Spikes, Warren County, 2:06.16
3. Charlie Osborne, Atlanta Classical, 2:08.39
4. Joe Thomas, Portal, 2:09.26

## 200 Meter Dash

1. Quincy Edwards, Calhoun County, 22.45
2. JP Powell, Miller County, 22.68
3. Jemari Sanders, Dooly County, 22.74
4. Na'Brentis Jackson, Chattahoochee Co., 22.80

## 300 Meter Hurdles

1. Jordan Coney, Treutlen, 39.59
2. Jaris Moye, Jenkins County, 39.92
3. Stacy Adams, Treutlen, 40.87
4. Tyrese Cook, Schley County, 41.21

## 3200 Meter Run

1. Julian Council, Georgia Military, 10:54.12
2. Jordan Overman, Georgia Military, 11:07.80
3. Edwin Gonzalez, Furlow Charter, 11:10.42
4. Ian Biedermann, Furlow Charter, 11:12.60

## 4x400 Meter Relay

1. Montgomery Co. 3:29.66 (Demorrius Brooker; Jamarion Henderson; Jakobe Mobley; Jordyn Patterson)

2. Portal 3:33.88 (Micah Williams; Amir Jackson; Kasen Evans; Joe Thomas)
3. Jenkins Co. 3:34.24 (Marion Young; Ge'Marion Newton; Javarius Gilmore; Jaris Moye)
4. Marion Co. 3:35.36 (Chris Gutierrez; Calvin Josey; Riley Phillips; Edgar Montas)

## 4x800 Meter Relay

1. GMC 8:42.20 (Walker Bloodworth; Joel Deen; Julian Council; Nathan Gise)
2. Montgomery Co. 8:43.61 (Charles Rogers; Jamarion Henderson; Jakobe Mobley; Jordyn Patterson)
3. Mitchell Co. 9:02.49 (Terrell Mathis Jr.; Patrick Wilder; Jarren Davis; Willie Davis)
4. Treutlen 9:03.30 (Zach Edge; Zay Lewis; De Micah Williams; Jaiquon McKinney)

## 4x200 Meter Relay

1. McIntosh Co. 1:30.69 (Lorinzo Reed; Jaylan Dallas; DeMarion McNear; Reggie Stevens)
2. Jenkins Co. 1:31.01 (Christian Wilson; Marion Young; Robtravius Coney; Calvin Adams)
3. Greene Co. 1:31.53 (Doremus Alexander; Henry Mitchell; Jaden Dorsey; Javius Cleveland)
4. Calhoun Co. 1:31.58 (Quincy Edwards; Carmello Gudes; Jai'Yon Carr; Talaun Jones)

## Team Scores

- |                                  |    |
|----------------------------------|----|
| 1. Montgomery County.....        | 58 |
| 2. Schley County.....            | 46 |
| 3. Georgia Military College..... | 43 |
| 4. McIntosh County Academy.....  | 40 |

### Class A, Division 2 GIRLS

#### Discus Throw

1. Jayna Kearson, ECI, 121-10
2. Jerrica Bryant, McIntosh Co. Acad., 119-09
3. Taneria Williams, Seminole County, 107-02
4. teasha Hardwick, Randolph-Clay, 104-11

#### High Jump

1. Marley Bell, Montgomery County, 5-02.00
2. Tykhia Burgess, Turner County, 5-00.00
3. Caitlyn Burgess, Turner County, 5-00.00
4. Alasia Montgomery, Taylor County, 4-10.00

#### Long Jump

1. Tykhia Burgess, Turner County, 16-09.50
2. Jabrayla Coglin, Montgomery Co., 16-08.75
3. Zariyona Williams, Miller County, 16-05.50
4. Marissa Green, Charlton County 16-05.50

#### Pole Vault

1. Mary Grace Welch, Baconton Char., 8-00.00
2. Madison Coalson, Baconton Charter, 7-06.00
2. Emily Wilder, Schley County, 7-06.00
4. Erin Johnson, Hawkinsville, 6-06.00

#### Shot Put

1. Jerrica Bryant, McIntosh Co. Acad., 36-06.00
2. Kelly Robinson, Mitchell County, 33-01.25
3. teasha Hardwick, Randolph-Clay, 32-00.00
4. Raelyn Felkel, ECI, 31-03.00

#### Triple Jump

1. Marley Bell, Montgomery County, 35-09.75
2. Marissa Green, Charlton County, 35-01.25
3. Taylor Knox, Charlton County, 33-08.50
4. Daneria Thornton, Schley County, 32-07.50

## 4x100 Meter Relay

1. Marion Co. 49.70 (Tori Green; Summer Starr; Sage Davis; Keyonna Rhodes)

# STATE TRACK MEETS - 2023

- Mt. Zion 50.41 (Carlissa Randall; Chelsey Hogsed; Zoey Holland; Shaniah Farley)
- Turner Co. 51.04 (Zy'Najia Lawson; Tykhia Burgess; Avoriana Section; Caitlyn Burgess)
- Mitchell Co. 51.54 (Amira Walters-Smith; Trinity Thomas; Amayane Middlebrooks; Unique Lee)

## 1600 Meter Run

- Flora Tyler, Atlanta Classical, 5:34.54
- Maria Knapp, Georgia Military, 5:40.30
- Savannah Arnett, Portal, 5:51.51
- Geisha Smith, Seminole County, 6:02.73

## 400 Meter Dash

- Michelle Balmer, Chattahoochee Co., 1:00.80
- Rha'Mya Hughes, Miller County, 1:01.69
- Hailey Scott, Portal, 1:01.74
- Lily Ryan, Georgia Military College, 1:02.40

## 100 Meter Dash

- Chavondria Crimes, Stewart County, 12.47
- Zariyona Williams, Miller County, 12.49
- Caitlyn Burgess, Turner County, 12.57
- Keyonna Rhodes, Marion County, 12.69

## 100 Meter Hurdles

- Marley Bell, Montgomery County, 15.27
- Syriah Hogan, Lincoln County, 16.59
- Curtevia Blair, Johnson County, 16.77
- Marissa Green, Charlton County, 17.00

## 800 Meter Run

- Maria Knapp, Georgia Military, 2:28.13
- Marcy Delgado, Wheeler County, 2:40.10
- Lily Ryan, Georgia Military College, 2:41.01
- Cameron Rogers, Wash.-Wilkes, 2:41.03

## 200 Meter Dash

- Zariyona Williams, Miller County, 26.01
- Kayilynn Straughn, Utopian Academy, 26.32
- Jacorra Russell, Early County, 26.60
- Navaeh Campbell, Jenkins Co., 26.84

## 300 Meter Hurdles

- Marley Bell, Montgomery County, 45.44
- Jada Batten, Telfair County, 47.48
- Curtevia Blair, Johnson County, 48.71
- Meya Hilt, Portal, 49.27

## 3200 Meter Run

- Flora Tyler, Atlanta Classical, 11:27.83
- Savannah Arnett, Portal, 13:06.07
- Geisha Smith, Seminole County, 14:28.51
- Madi McMahan, McIntosh Co. Acad., 14:32.08

## 4x400 Meter Relay

- Georgia Military 4:19.01 (Nyla Jackson; Maria Knapp; Meadow Roberts; Lily Ryan)
- Montgomery 4:28.62 (Miracle Nobles; Laurie Conner; Ashmira Moye; Jabrayla Coglin)
- Lincoln Co. 4:31.51 (Madison Collier; Syriah Hogan; Janai Mickens; Mary Claire Matthews)

- Hawkinsville 4:31.88 (Karia Nelson; Akeelah Brown; Kaniyah Anderson; Myah Brown)

## 4x800 Meter Relay

- Georgia Military 10:49.06 (Lily Ryan; Lana Wood; Hannah Watkins; Maria Knapp)
- Portal 11:06.61 (Hailey Scott; April Barnes; Savannah Arnett; Blair Brannen)
- Atlanta Classical 11:08.95 (Sara Neil Kirkland; Sarah Adams; Flora Tyler; Adeline Weinheimer)
- Furlow Char. 11:34.97 (Jacklyn Chen; Isabel Amato; Maria Kilheffer; Elizabeth Arizmendi)

## 4x200 Meter Relay

- Miller Co. 1:45.95 (Erika Harris; Precious Collins; Rha'Mya Hughes; Zariyona Williams)
- Turner Co. 1:48.60 (Caitlyn Burgess; Ta'Liyah Martin; Zy'Najia Lawson; Tykhia Burgess)
- Mitchell Co. 1:49.39 (Unique Lee; Amayane Middlebrooks; Trinity Thomas; Amira Walters-Smith)
- Montgomery Co. 1:49.67 (Zoe Jordan; Ashmira Moye; Kee'Mariah Williams; Jabrayla Coglin)

## Team Scores

- Montgomery County.....71
- Georgia Military College.....49
- Miller County.....48
- Turner County.....48

# - New State Record

# WHEELCHAIR & AMBULATORY TRACK - 2023

## 2023 RESULTS

### BOYS WHEELCHAIR

#### SHOT PUT (Class 2)

- Max Richardson, Calhoun, 4-10.50

#### 200 METER RACE

- Hunter Martin, Portal, 45.54

#### 800 METER RACE

- Hunter Martin, Portal, 3:25.61

#### Team Totals

- Portal.....20
- Calhoun.....10

### BOYS AMBULATORY

#### SHOT PUT

- Kenneth Escobar, Dalton, 28-04.00

#### DISCUS THROW

- Kenneth Escobar, Dalton, 55-10

#### Team Totals

- Dalton.....20

### GIRLS AMBULATORY

#### 100 METER DASH

- Katherine Farr, Westminster, 24.94

#### 200 METER DASH

- Katherine Farr, Westminster, 59.76

#### SHOT PUT

- MaCayla Moody, Northside-WR, 33-04.50

#### Team Totals

- Westminster.....20
- Northside-Warner Robins.....10

## RECORDS

### BOYS WHEELCHAIR

SHOT PUT(Class 1).....29-01.50  
Robert Berry, Dacula, 2016

SHOT PUT(Class 2).....20-00.00  
Cade Maynor, Pepperell, 2021

200 METER RACE.....30.96  
Robert Berry, Dacula, 2016

800 METER RACE.....2:01.07  
Zach Bobowski, South Forsyth, 2004

### GIRLS WHEELCHAIR

SHOT PUT(Class 1).....19-08.5  
Curran Brown, Johns Creek, 2013

SHOT PUT(Class 2).....14-10.00  
Audrey Seigler, Westside-Augusta, 2008

200 METER RACE.....35.50  
Christina Young, Cass, 2012

GIRLS 800 METER RACE.....2:25.94  
Christina Young, Kennesaw Mt., 2009

### BOYS AMBULATORY

200 METER DASH.....26.88  
Adam Kiel, North Paulding, 2019

SHOT PUT.....28-04.00  
Kenneth Escobar, Dalton, 2023

DISCUS THROW.....55-10  
Kenneth Escobar, Dalton, 2023

### GIRLS AMBULATORY

DISCUS THROW.....51-10.00  
Cathryn Gray, Centennial, 2019

SHOT PUT.....33-04.50  
MaCayla Moody, Northside-WR, 2023

100 METER DASH.....23.11  
Cathryn Gray, Centennial, 2019

200 METER DASH.....59.04  
Katherine Farr, Westminster, 2022

# STATE VOLLEYBALL TOURNAMENTS - 2022-23

## 7A

### First Round

North Cobb 3, West Forsyth 0  
 North Gwinnett 3, Dacula 0  
 Harrison 3, Archer 0  
 Richmond Hill 3, Campbell 0  
 Cherokee 3, Denmark 0  
 Buford 3, Duluth 0  
 Marietta 3, Parkview 0  
 East Coweta 3, Colquitt Co. 0  
 Carrollton 3, Valdosta 0  
 Hillgrove 3, Grayson 0  
 Peachtree Ridge 3, Mill Creek 1  
 Walton 3, Forsyth Central 0  
 Lowndes 3, Westlake 1  
 Brookwood 3, N. Paulding 2  
 Norcross 3, Mountain View 2  
 Lambert 3, Kennesaw Mtn. 0

### Round 2

North Gwinnett 3, North Cobb 0  
 Harrison 3, Richmond Hill 0  
 Buford 3, Cherokee 0  
 East Coweta 3, Marietta 1  
 Hillgrove 3, Carrollton 0  
 Walton 3, Peachtree Ridge 0  
 Brookwood 3, Lowndes 0  
 Lambert 3, Norcross 0

### Quarterfinals

North Gwinnett 3, Harrison 0  
 Buford 3, East Coweta 0  
 Walton 3, Hillgrove 1  
 Lambert 3, Brookwood 0

### Semifinals

Buford 3, North Gwinnett 0  
 Lambert 3, Walton 1

### Final

Buford 3, Lambert 2  
 (22-25, 25-18, 25-15, 23-25, 19-17)

## 6A

### First Round

Etowah 3, East Paulding 0  
 Pope 3, Gainesville 0  
 Dunwoody 3, Rockdale Co. 0  
 Houston Co. 3, S. Effingham 1  
 Allatoona 3, Paulding Co. 0  
 Johns Creek 3, Jackson Co. 2  
 Marist 3, Jonesboro 0  
 Effingham Co. 3, Veterans 0  
 Glynn Acad. 3, Tift County 1  
 Woodward 3, Riverwood 1  
 North Forsyth 3, Lassiter 1  
 Newnan 3, Woodstock 0  
 Lakeside-Evans, Lee County 1  
 St. Pius X 3, Morrow 0  
 Alpharetta 3, Lanier 1  
 Sequoyah 3, Alexander 0

### Round 2

Pope 3, Etowah 0  
 Houston Co. 3, Dunwoody 1  
 Johns Creek 3, Allatoona 2  
 Marist 3, Effingham Co. 1  
 Glynn Acad. 3, Woodward 1  
 North Forsyth 3, Newnan 2  
 St. Pius X 3, Lakeside-Evans 0  
 Sequoyah 3, Alpharetta 0

### Quarterfinals

Pope 3, Houston County 0  
 Johns Creek 3, Marist 2  
 North Forsyth 3, Glynn Acad. 0  
 Sequoyah 3, St. Pius X 1

## Semifinals

Pope 3, Johns Creek 0  
 Sequoyah 3, North Forsyth 0  
**Final**  
 Pope 3, Sequoyah 2  
 (21-25, 21-25, 25-20, 25-16, 15-11)

## 5A

### First Round

Chattahoochee 3, Tri-Cities 0  
 Dalton 3, Loganville 0  
 Northside-Col. 3, Decatur 0  
 Greenbrier 3, Dutchtown 1  
 Kell 3, Midtown 0  
 Jefferson 3, Cass 0  
 Harris Co. 3, Arabia Mtn. 0

Locust Grove 3, Bradwell Inst. 0  
 Ola 3, Ware Co. 0  
 McIntosh 3, Tucker 0

Winder-Barrow 3, Calhoun 0  
 Villa Rica 3, Cambridge 1  
 Statesboro 3, Eagles Landing 0  
 Chamblee 3, Northgate 1  
 Cartersville 3, Flowery Branch 0  
 GACS 3, Jackson-Atlanta 0

### Round 2

Chattahoochee 3, Dalton 0  
 Greenbrier 3, Northside-Col. 2  
 Jefferson 3, Kell 1  
 Locust Grove 3, Harris Co. 0  
 McIntosh 3, Ola 0  
 Winder-Barrow 3, Villa Rica 2  
 Statesboro 3, Chamblee 2

### Quarterfinals

GACS 3, Cartersville 1  
 Chattahoochee 3, Greenbrier 1  
 Jefferson 3, Locust Grove 2  
 McIntosh 3, Winder-Barrow 1  
 GACS 3, Statesboro 1

### Semifinals

Chattahoochee 3, Jefferson 1  
 GACS 3, McIntosh 2

### Final

GACS 3, Chattahoochee 1  
 (21-25, 26-24, 26-24, 25-18)

## 4A

### First Round

Lovett 3, SW DeKalb 0  
 Sonoraville 3, North Oconee 2  
 Wayne County 3, Griffin 2  
 Shaw 3, Fayette County 0  
 Westminster 3, Riverdale 0  
 Cherokee Bluff 3, SE Whitfield 0  
 SE Bulloch 3, Stockbridge 0  
 Whitewater 3, Baldwin 0  
 Starr's Mill 3, Perry 0  
 Islands 3, Woodland-Henry 0  
 Heritage-Cat. 3, Chastatee 2  
 Pace Acad. 3, Stephenson 0  
 Trinity Chr 3, Hardaway 0  
 Hampton 3, New Hampstead 1  
 N. Hall 3, Central-Carroll 1  
 Holy Innocents' 3, Walnut Grove 0

### Round 2

Lovett 3, Sonoraville 0  
 Shaw 3, Wayne County 0  
 Cherokee Bluff 3, Westminster 0  
 Whitewater 3, SE Bulloch 0  
 Starr's Mill 3, Islands 0  
 Pace Acad. 3, Heritage-Cat. 1

Trinity Christ. 3, Hampton 1  
 N. Hall 3, Holy Innocents' 2

### Quarterfinals

Lovett 3, Shaw 0  
 Whitewater 3, Cherokee Bluff 0  
 Pace Acad. 3, Starr's Mill 0  
 Trinity Christ. 3, North Hall 1

### Semifinals

Lovett 3, Whitewater 0  
 Pace Acad. 3, Trinity Christ. 0

### Final

Pace Academy 3, Lovett 0  
 (25-11, 25-23, 25-20)

## 3A

### First Round

Bremen 3, Cedar Grove 0  
 White County 3, Monroe Area 0  
 Sav. Cty. Day 3, Richmond Ac. 2  
 Columbus 3, Peach Co. 0  
 Adairsville 3, Carver-Atl. 0  
 Oconee Co. 3, Lumpkin Co. 0

St. Vincents 3, Harlem 0  
 Jackson 3, Crisp County 1  
 Mary Persons 3, Carver-Col. 0  
 Savannah Christ. 3, Salem 0  
 Hebron Christ. 3, Dawson Co. 0  
 Sandy Creek 3, Coahuilla Creek 0  
 Thomasville 3, Pike County 0  
 Morgan Co. 3, Calvary Day 0  
 Wesleyan 3, Hart County 0  
 LaFayette 3, Douglass-Atl. 0

### Round 2

White County 3, Bremen 0  
 Columbus 3, Sav. Cty. Day 2  
 Oconee County 3, Adairsville 0  
 St. Vincents 3, Jackson 0  
 Savannah Chr. 3, Mary Persons 0  
 Sandy Creek 3, Hebron Christ. 2  
 Morgan Co. 3, Thomasville 0  
 Wesleyan 3, LaFayette 1

### Quarterfinals

White County 3, Columbus 0  
 Oconee County 3, St. Vincents 0  
 Sandy Creek 3, Savannah Chr. 1  
 Morgan Co. 3, Wesleyan 0

### Semifinals

Oconee Co. 3, White County 1  
 Morgan Co. 3, Sandy Creek 1

### Final

Morgan Co. 3, Oconee Co. 2  
 (25-23, 19-25, 20-25, 25-16, 15-10)

## 2A

### First Round

N. Cobb Christ. 3, Towers 0  
 Fannin Co. 3, Fellowship Chr. 2  
 Toombs Co. 3, Tech. Career 0  
 ACE Charter 3, Spencer 0  
 Walker 3, South Atlanta 0  
 Athens Acad. 3, N. Murray 0  
 Appling Co. 3, Johnson-Aug. 0  
 Landmark Christ. 3, Northeast 0  
 ELCA 3, Cook 0

Savannah Arts 3, Putnam Co. 0  
 Providence Christ. 3, Model 0  
 Elite Scholars 3, KIPP 0  
 Callaway 3, Central-Macon 1  
 Davidson Arts 3, Pierce Co. 0  
 Union Co. 3, Murray Co. 2  
 Mt. Paran 3, Drew Charter 0

## Round 2

N. Cobb Christ. 3, Fannin Co. 0  
 ACE Charter 3, Toombs Co. 2  
 Athens Acad. 3, Walker 0  
 Landmark Chr. 3, Appling Co. 0  
 Savannah Arts 3, ELCA 0  
 Providence Christ. 3, Elite Sch. 0  
 Callaway 3, Dav Fine Arts 2  
 Mt. Paran 3, Union Co. 0

### Quarterfinals

N. Cobb Chr. 3, ACE Charter 0  
 Landmark Chr. 3, Athens Acad. 1  
 Savannah Arts 3, Providence 1  
 Mt. Paran 3, Callaway 0

### Final

Landmark Chr. 3, N. Cobb Chr. 1  
 Mt. Paran 3, Savannah Arts 1

## Semifinals

Mt. Paran 3, Landmark Christ. 0  
 (25-23, 25-18, 25-19)

## A

### First Round

Mt. Pisgah 3, Lk. Oconee Acad. 0  
 Armuchee 3, Athens Christ. 0  
 Heard Co. 3, Bryan County 0  
 Quitman Co. 3, Central-Tal. 0  
 Galloway 3, Aquinas 0  
 Tallulah Falls 3, Darlington 0  
 Lamar County 3, Savannah 1  
 Chatt. County 3, Early County 0  
 Taylor Co. 3, Mitchell Co. 0  
 Woodville-Tomp. 3, Greenville 0  
 Prince Avenue 3, Pepperell 0

Mt. Vernon 3, Oglethorpe Co. 0  
 Brooks Co. 3, Crawford Co. 1  
 Temple 3, McIntosh Co. Acad. 0  
 Dade County 3, Rabun County 1  
 Mt. Bethel 3, Social Circle 0

### Round 2

Mt. Pisgah 3, Armuchee 1  
 Heard Co. 3, Quitman Co. 0  
 Tallulah Falls 3, Galloway 1  
 Lamar County 3, Chatt. County 1  
 Woodville-Tomp. 3, Taylor Co. 0  
 Mt. Vernon 3, Prince Avenue 2  
 Temple 3, Brooks County 2  
 Mt. Bethel 3, Dade County 1

### Quarterfinals

Mt. Pisgah 3, Heard Co. 0  
 Tallulah Falls 3, Lamar Co. 0  
 Mt. Vernon 3, Woodville-Tomp. 0  
 Mt. Bethel 3, Temple 0

### Semifinals

Tallulah Falls 3, Mt. Pisgah 1  
 Mt. Bethel 3, Mt. Vernon 0

### Final

Tallulah Falls 3, Mt. Bethel 1  
 (25-20, 25-27, 25-14, 25-20)

# STATE WRESTLING TOURNAMENTS - 2023

## Class A

### 106 Lbs.

1. Conner Doherty, Mt. Pisgah
2. Justin Pearce, Screven Co.
3. Andravious Brihm, Dublin
4. Landon Headrick, Coosa

### 113

1. Braydon Mitchell, Social Circle
2. Clayton Loughridge, Trion
3. John Charles Moeser, Mt. Vernon
4. Michael Hedrick, Heard Co.

### 120

1. Connor Castillo, Social Circle
2. James Willingham, Trion
3. Kolby Dempsey, Armuchee
4. Nick Samples, Mt Zion-Carroll

### 126

1. Curtis Duren, Social Circle
2. Seth Huskins, Trion
3. Aden Davis, Darlington
4. Christian Lange, Mt. Pisgah

### 132

1. Brady Nardella, Mt. Pisgah
2. Gavin Carlton, Chattooga
3. Crawford Lee, Trion
4. Carter Fleming, Elbert Co.

### 138

1. Marley Washington, Mt. Pisgah
2. Andrew Jones, Trion
3. Kolton Edge, Pepperell
4. Mason Gillespie, Heard Co.

### 144

1. Braderick Bennett, Temple
2. Zachery Lee, Swainsboro
3. Jace Parent, St Francis
4. Lance Thacker, Social Circle

### 150

1. Tyler Nelson, Mt. Pisgah
2. Gus Hames, Trion
3. James Eldridge, Social Circle
4. Cole Page, East Laurens

### 157

1. Joey Bertrand, Mt. Pisgah
2. Cade Parent, St Francis
3. Kacen Taylor, Social Circle
4. Roman Coley, East Laurens

### 165

1. Toby Maddux, Trion
2. Brayden Phillips, Commerce
3. Sean Crews, Social Circle
4. Miles Watts, Rabun Co.

### 175

1. Matthew Waddell, Pepperell
2. Josh Lange, Mt. Pisgah
3. Cohen Blaschke, Trion
4. Jaxon Ethridge, Social Circle

### 190

1. Logan Eller, Trion
2. Tysean Wiggins, Commerce
3. Ethan Price, Montgomery Co.
4. Christian Brock, Social Circle

### 215

1. Landon Williams, Dade Co.

2. Hoke Poe-Hogan, Commerce
3. Jacob Griffith, East Laurens
4. Lane Harris, Trion

### 285

1. Clint Williamson, Lamar Co.
2. Michael Joiner, Irwin Co.
3. Levi Shaw, Jasper Co.
4. Zander McLane, Commerce

### Team Scores

- |                       |       |
|-----------------------|-------|
| 1. Social Circle..... | 224.0 |
| 2. Mt. Pisgah.....    | 200.5 |
| 3. Trion.....         | 198.5 |
| 4. Commerce.....      | 82.0  |

## Class 2A

### 106 Lbs.

1. Brandon Locke, North Murray
2. Malachi Macedonio, Rockmart
3. Charlie Wheeler, East Jackson
4. Ziare Perry, Jordan

### 113

1. Hagen Sharp, Rockmart
2. Blake Summers, Fannin Co.
3. Elijah Hardin, North Murray
4. Wyatt Stanley, Putnam Co.

### 120

1. TK Davis, Rockmart
2. Allen Calderon, ELCA
3. Angel Cruz, Banks Co.
4. Christian White, Glenn Hills

### 126

1. Gunner Chambers, Rockmart
2. Thawbaan As-Siddiq, Columbia
3. Joshua Smith, East Jackson
4. Cooper Moreland, Fannin Co.

### 132

1. James Murray, Rockmart
2. Phillip Berni, Jordan
3. Anderson Clouse, Union Co.
4. Jaylen Thomas, Cook

### 138

1. Taylor Collis, Fannin Co.
2. Ethan Carter, Haralson Co.
3. Caleb Blair, Murray Co.
4. Dabvn Wadley, Toombs Co.

### 144

1. Carson Collis, Fannin Co.
2. Hunter Wilson, Rockmart
3. Jansen Kilgore, Dodge Co.
4. Tucker Hardeman, ELCA

### 150

1. Ben Lampe, East Jackson
2. Gabriel Hightower, Vidalia
3. Asa Smith-Foot, Union Co.
4. Rylee Kines, Model

### 157

1. Kellon Walley, Banks Co.
2. Jed Rountree, Cook
3. Payton Legatt, Union Co.
4. Jack Godbee, Vidalia

### 165

1. Nahzir Turner, Rockmart
2. Matthew Lopez, Berrien Co.
3. David Heradia, Union Co.

4. Michael Hyatt, Haralson Co.

### 175

1. Corbin Davenport, Fannin Co.
2. Riley Davis, Model
3. Jesiah Townsel, Vidalia
4. Austin Wooten, Rockmart

### 190

1. Noah Allmon, Model
2. Tank Morris, Toombs Co.
3. Ronald Pointer, Vidalia
4. Tyler Malone, Rockmart

### 215

1. Jaden Lyons, Pierce Co.
2. Wil Watts, Toombs Co.
3. Matthew Crowder, Fannin Co.
4. Malcom Burris, Fitzgerald

### 285

1. Jase Davis, Rockmart
2. Josh Petty, Fellowship Christ.
3. Logan Long, Fannin Co.
4. Brock Nobles, Toombs Co.

### Team Scores

- |                   |       |
|-------------------|-------|
| 1. Rockmart.....  | 244.5 |
| 2. Fannin Co..... | 169.5 |
| 3. Toombs Co..... | 101.0 |
| 4. Vidalia.....   | 96.0  |

## Class 3A

### 106 Lbs.

1. Juan Rafael, Gilmer Co.
2. Adonnis Sanchez, Coahuilla Cr.
3. Elijah Karr, Bremen
4. Ayden Stanley, Pike Co.

### 113

1. Mason Persons, Columbus
2. Greyson Cooper, Bremen
3. Leonardo Domingo, Gilmer
4. Davin Lightsey, White Co.

### 120

1. Jonathan McDaniel, Columbus
2. Carson Farist, Gilmer
3. Landon Brown, Gordon Lee
4. Danny Liddy, Coahuilla Creek

### 126

1. Pierce Pennington, Ringgold
2. Dylan Gonzalez, Pickens
3. Cayden Autry, White Co.
4. Dylan Ivey, Mary Persons

### 132

1. Austin Marshall, Lumpkin Co.
2. Gavin Mastrangelo, Bremen
3. Bregan Berry, Gilmer
4. Hudson Moss, Ringgold

### 138

1. Nathan Neilson, Lumpkin Co.
2. Philip Jax, Pickens
3. William Ballenger, Franklin Co.
4. Luke Johnson, Bremen

### 144

1. Tristan Busch, Ringgold
2. Jacob Baughcum, Franklin Co.
3. TJ Payne, Lumpkin Co.
4. William Tredy, Ridgeland

### 150

1. Nathan Bowen, Oconee Co.
2. Gage Lee, Pike Co.
3. Nick Kapherr, Lakeview-Ft. Og.
4. James Bumgardner, Bremen

### 157

1. Anthony Mannella, Mary Persons
2. Cason Cannon, Pickens
3. Peyton White, Hart Co.
4. Jonah Burger, Franklin Co.

### 165

1. Zillion Hammond, Monroe Area
2. Jake Neu, Wesleyan
3. Eli Brown, Peach Co.
4. Mason Powell, Pickens

### 175

1. Tyler Secoy, Columbus
2. Brady Simms, Franklin Co.
3. Jacob Brown, LaFayette
4. Christopher Morgan, Morgan Co.

### 190

1. Diego Jacinto, Gilmer
2. Trent DeBow, Wesleyan
3. Ca' Vaughn Durham, Monroe Area
4. Mike Nichols, Lumpkin Co.

### 215

1. Kaleb Nicholson, Pickens
2. Caleb Turner, Morgan Co.
3. David Beverly, West Hall
4. Seth Hogan, Monroe Area

### 285

1. Tyranny McGowan, Columbus
2. Jett Johnson, Adairsville
3. Terrence Herrin, Hephzibah
4. JD Trowell, White Co.

### Team Scores

- |                  |       |
|------------------|-------|
| 1. Gilmer.....   | 115.0 |
| 2. Pickens.....  | 110.0 |
| 3. Bremen.....   | 108.0 |
| 3. Ringgold..... | 108.0 |

## Class 4A

### 106 Lbs.

1. Gabe Swann, Central-Carroll
2. Tate Thomas, Heritage-Catoosa
3. Patrick Smyth, Lovett
4. Noah Chastain, Sonoraville

### 113

1. Alex Hyman, Lovett
2. Olliver Webb, SE Whitfield
3. Alexis Guardado, Chestatee
4. Zack Gray, Cedartown

### 120

1. Ty Murray, Central-Carroll
2. Cole Cano, North Oconee
3. Amadou Diallo, Mt Zion-Jones.
4. Ty Boldin, New Hampstead

### 126

1. Cael Kusky, Lovett
2. Elijah Ward, Troup
3. Danny Krutules, Central-Car.
4. Robert Crim, Westminster

### 132

1. Adam Payton, Cedartown
2. Colson Hoffman, Central-Car.

# STATE WRESTLING TOURNAMENTS - 2023

- Ely Raines, Chestatee
- Steven Morales, SE Whitfield

## 138

- Braydon Bowen, Troup
- Jayden Hammonds, SW DeKalb
- Jake Kennedy, Lovett
- Gage Mason, Cedartown

## 144

- Dom Lasher, North Oconee
- Connor Free, North Hall
- Owen Warren, Central-Carroll
- Xion Jackson, Hardaway

## 150

- JT Bowers, West Laurens
- Zeb Dawkins, Walnut Grove
- Jace Jachimski, Madison Co.
- Nicholas Moffett, Lovett

## 157

- Dharrin Smith, SW DeKalb
- Tim Dunn, Troup
- Joey Carew, North Hall
- Jackson Moffit, East Forsyth

## 165

- Chris Mance, Lovett
- Drake Wood, West Laurens
- Nick Morgan, Holy Innocents
- Guensley Sajous, Hardaway

## 175

- Jerrel Baskins, SW Dekalb
- Evan Wingrove, Heritage-Cat.
- Zeke Harris, North Hall
- Josh Fillingame, Bainbridge

## 190

- Landen Moss, Walnut Grove
- Alvinno Cheeks, Stockbridge
- Tanner Ramm, Cairo
- Cooper Thomas, Westminster

## 215

- Isaiah Scott, SW Dekalb
- Parker Warren, Walnut Grove
- Tristan Mullins, Sonoraville
- Tye Bias, Hardaway

## 285

- Caleb Pruitt, East Hall
- Christian Bell, Lovett
- Guillermo Rosales, Johnson
- Donovan Funsch, Perry

## Team Scores

- Lovett .....161.0
- Central-Carroll.....120.5
- Southwest DeKalb.....97.0
- Chestatee.....92.0

### Class 5A

## 106 Lbs.

- Lee Camp, Cass
- Nick Nguyen, Harris Co.
- Robert Magana, Chapel Hill
- Hunter McCleskey, Jones Co.

## 113

- Roman Belardo, Jefferson
- Mason Moody, Locust Grove
- Hunter Barrett, Cass

- Nolan Christian, Eastside

## 120

- Chaz McDonald, Jefferson
- Tristan Malette, Locust Grove
- Brody Parker, Calhoun
- Cristian Sampson, Eagles Landing

## 126

- Jake Crapps, Cass
- Davis Culpepper, Harris Co.
- Hunter Keane, Cambridge
- Paul Lanier, Woodland-Bartow

## 132

- Dallas Russell, Jefferson
- Rowdy Duck, Cass
- J'Veion Redmon, Ola
- Jordan Hittle, Eastside

## 138

- Davis Dollar, Jefferson
- Conner Kimbrough, Ola
- Hayden Santora, Woodland-Bar.
- Tanner Toups, Cass

## 144

- Tyler McKnight, Cass
- Brian Papcun, Ola
- Crisjaniel Martinez-Antonetty, Greenbrier
- Zachary Wallace, Woodland-Bar.

## 150

- Cullen Kane, Cambridge
- Davin Lundquist, Harris Co.
- Jared Walker, Ola
- Boston Mcdermott, Greenbrier

## 157

- Seth Larson, Flowery Branch
- Isaac Green, Calhoun
- Krieg Roe, Cass
- Cam Ashton, Chapel Hill

## 165

- Zach McKnight, Cass
- Griffin Harper, Flowery Branch
- Xander Dossett, Ola
- Brock Johnson, Harris Co.

## 175

- Creed Thomas, Jefferson
- Zion Smith, Ola
- Chi Anderson, Jones Co.
- Michael Turner, Loganville

## 190

- Luke Cochran, Jefferson
- Jatavius Williams, Coffee
- Cal Rockenbach, Flowery Brn.
- Brandon Perez, Villa Rica

## 215

- Charles Higdon, Woodland-Bar.
- Jason Eligwe, Loganville
- Sryker Woods, Dalton
- Jabare George, Ware Co.

## 285

- Sammy Brown, Jefferson
- Riley Souther, Dalton
- Gavin Proffitt, McIntosh
- Kwadrus Wilson, Woodland-Bar.

## Team Scores

- Jefferson.....213.5
- Cass.....208.0
- Ola.....153.5
- Woodland-Bartow.....96.5

### Class 6A

## 106 Lbs.

- Jose Pacheco, Jackson Co.
- Mal Santiago, Effingham Co.
- Forest Briesacher, Marist
- Karol Olalde, Lee Co.

## 113

- Riley McElligott, Lassiter
- Tyler Ramos, Lanier
- Alexander Tabb, Lee Co.
- Heath Augustyn, Woodward

## 120

- Damien Johnson, Veteran's
- Carter Brickley, Lassiter
- Hunter Kegley, Glynn Acad.
- Alexander Reid, Alpharetta

## 126

- Tanner Spalding, Woodward
- Jefferson Cuttino, Glynn Acad.
- Jake Labasi, Sequoyah
- John Termini, Marist

## 132

- Josh Sanders, Sprayberry
- Riley Brewer, Lee Co.
- Brandon Bringer, S. Effingham
- Ramon Castillo, Jackson Co.

## 138

- Thomas Rhodes, Roswell
- Cade Morgan, Glynn Academy
- Peter Gunter, Sequoyah
- Maddox Sisk, Paulding Co.

## 144

- Dmitriy Vostrikov, N. Forsyth
- Trevor Kantor, Blessed Trinity
- Mario Bolivar, Gainesville
- Comari Cone, Brunswick

## 150

- Aidan Karpinski, Pope
- Ryan Seymour, South Paulding
- Dylan Reel, Woodward
- Christopher Henderson, N. Forsyth

## 157

- Thomas Riordan, Blessed Trin.
- Enrique Santana, S. Effingham
- Blake Ethridge, Brunswick
- Xavier Cepican, Jackson Co.

## 165

- Robby DeHaven, Woodward
- Aiden Chilson, Lee County
- Michael Hall, Alexander
- Ashton Tootle, S. Effingham

## 175

- Latrell Schafer, Veterans
- Joseph Lago, Etowah
- Xavier Souder, Woodward
- Damion Moate, Tift County

## 190

- Brock Hacker, Johns Creek
- Colin Kelley, North Forsyth
- Eason Martin, Houston Co.
- Xavier Byams, Marist

## 215

- Anthony Lowe, Brunswick
- Weston Bryan, Lee Co.
- Mbah Mbanwei, Rockdale Co.
- Sky Niblett, Gainesville

## 285

- Ashton Anderson, S. Effingham
- Jaylin Tate, Woodward
- Marquis Moss, Grovetown
- Albert Goodgame, Rome

## Team Scores

- Woodward.....124.0
- South Effingham.....103.0
- Lee Co.....101.0
- Jackson Co.....87.5

### Class 7A

## 106 Lbs.

- Bradley Patterson, Camden Co.
- DJ Clarke, Buford
- Nicolas Owens, N. Gwinnett
- Brenden Fair, Richmond Hill

## 113

- Antonio Mills, Mill Creek
- Rylan Ibold, Buford
- Brandon Higgins, Camden Co.
- Gilbert Balbuena, Brookwood

## 120

- Hunter Prosen, Camden Co.
- Colin Dragon, Richmond Hill
- Reed Walker, West Forsyth
- Ty Gentry, Buford

## 126

- Blue Stiffler, Mill Creek
- Maddox McArthur, Buford
- Ethan McCullough, Lowndes
- Brock Weaver, Camden Co.

## 132

- Amantee Mills, Mill Creek
- Noah Danforth, West Forsyth
- Collin Mullins, North Paulding
- Anthony Santos, Camden Co.

## 138

- Drew Gorman, Buford
- Antoine Glasgow, Parkview
- Logan Weaver, North Gwinnett
- Tyson Wilson, Peachtree Ridge

## 144

- Gavin Pope, Buford
- Josh Denson, North Paulding
- Banks Bitterman, Mill Creek
- Gavin Daniels, Camden Co.

## 150

- Malachi Sanders, Marietta
- Emil Necula, Walton
- JT McCullough, Buford
- Ryan Banister, Camden Co.

# STATE WRESTLING TOURNAMENTS - 2023

## 157

1. Caide Daltro, West Forsyth
2. Konlin Weaver, Camden Co.
3. Dylan Lobdell, Lambert
4. Jaheim Mills, Mill Creek

## 165

1. Dominic Babinelli, Mill Creek
2. Grayson Santee, Buford
3. Kian Hauser, East Coweta
4. Elijah Castillo, Lambert

## 175

1. Ryder Wilder, Camden Co.
2. Conor McCloskey, Buford
3. Landon Jones, Harrison
4. Ronan Sherwood, N. Gwinnett

## 190

1. Connor Cooper, Hillgrove
2. Aaron Riner, Buford
3. Michael Heyliger, North Cobb
4. Britt Blair, Camden Co.

## 215

1. Zion Rutledge, Hillgrove
2. Cole Williams, South Forsyth
3. Rhyen Miller, North Paulding
4. Dustin Edenfield, Camden Co.

## 285

1. John Levy, Carrollton
2. JaQuavian Daniels, Colquitt Co.
3. Grant Laskey, Lowndes
4. Jesse Batten, Camden Co.

## Team Scores

1. Camden Co.....233.0
2. Buford.....219.0
3. Mill Creek.....158.5
4. North Paulding.....82.5

## Girls

### 100 Lbs.

1. Artemis Eaton, North Forsyth
2. Aneri Patel, Woodward
3. Kaitlyn Brown, Dodge Co.
4. Jordan Epstein, Greenbrier

### 105

1. Ollie Kate Weiland, White Co.
2. Courtney Hawkins, Chestatee
3. Lilianna McKinley, Carrollton
4. Destine Hirschy, ECI

### 110

1. Delialah Betances, Lee Co.
2. Olivia D'Arienzo, N. Paulding
3. Isabella West, Richmond Hill
4. Alyssa Roberts, River Ridge

### 115

1. Vera Spencer, North Oconee
2. Brooke French, Allatoona
3. Kalayah Edwards, Newton
4. Nyla Barmore, Rockdale Co.

### 120

1. Kaitlyn Fields, Cedartown
2. Zabby Okoli, Woodward
3. Evie Brown, Ware Co.

4. Alanna Garner, River Ridge

## 125

1. Jasmine Jenkins-Bey, Columbus
2. Marigona Lau, Glynn Academy
3. Millie Hughes, Jefferson
4. Leticia Tercero, Gilmer

## 130

1. Elle Kaufmann, Lovett
2. Samantha Patton, Cook
3. Abby Plemons, Chestatee
4. Mariana Perez, Denmark

## 135

1. May Prado, Lassiter
2. Te'arah Lett, Monroe Area
3. Nora Garbuzovas, Lumpkin Co.
4. Ryli Howe, Model

## 140

1. Greta Garbuzovas, Lumpkin Co.
2. Kendra Heroch, Chattooga
3. Ariana Bacon, Greenbrier
4. Alana Malone, Shaw

## 145

1. Raven Cook, Jackson Co.
2. Madison Cooley, Carrollton
3. Shonticia Taft, Osborne
4. Madison Secoy, Columbus

## 155

1. Ashley Godinez, Chestatee
2. Gabriel Phillips, Grovetown

3. Ayana Fletcher, Northside-Col.
4. Zoe Parris, Cherokee

## 170

1. Genevieve An, Kennesaw Mtn.
2. Mia Bernacki, Effingham Co.
3. Litzy Soto, Johnson
4. Terra Burse, SE Whitfield

## 190

1. Taylor Schiesser, Gilmer
2. Jaden Lee, Chestatee
3. Adisen Lowell, Harris Co.
4. Anetra Witherspoon, Cartersville

## 235

1. Lilly Chavis, Jackson Co.
2. Stephanie Galvan, Norcross
3. Kayla Mckenzie, Alexander
4. Isabella Redlinger, Chestatee

## Team Scores

1. Vacated
2. Carrollton.....52.0
3. Gilmer.....52.0
4. Jackson Co.....44.0

# TEAM DUAL WRESTLING - 2023

## 7A

- |                     |                    |
|---------------------|--------------------|
| 1. Camden County 39 | 3. Mill Creek 50   |
| 2. Buford 22        | 4. West Forsyth 27 |

## 6A

- |                    |                   |
|--------------------|-------------------|
| 1. S. Effingham 36 | 3. Woodward 42    |
| 2. West Forsyth 28 | 4. Glynn Acad. 29 |

## 5A

- |                 |                     |
|-----------------|---------------------|
| 1. Jefferson 37 | 3. Ola 60           |
| 2. Cass 33      | 4. Harris County 19 |

## 4A

- |                       |                    |
|-----------------------|--------------------|
| 1. Central-Carroll 34 | 3. Chestatee 42    |
| 2. Lovett 33          | 4. North Oconee 30 |

## 3A

- |                |                       |
|----------------|-----------------------|
| 1. Columbus 34 | 3. Ringgold 40        |
| 2. Gilmer 33   | 4. Franklin County 35 |

## 2A

- |                     |                        |
|---------------------|------------------------|
| 1. Rockmart 47      | 3. Toombs County 43    |
| 2. Fannin County 22 | 4. Landmark Christ. 27 |

## A

- |                  |                     |
|------------------|---------------------|
| 1. Mt. Pisgah 33 | 3. Social Circle 76 |
| 2. Trion 32      | 4. Oglethorpe Co. 3 |

# STATE AIR RIFLERY - 2023

## INDIVIDUAL SCORES

1. Madison Kennedy, Georgia Military College.....395.7
2. Maddy Moyer, Lumpkin County.....395.4
3. Jordan DeJesus, Camden County.....393.9
4. Liv Lusky, Lumpkin County.....393.9

## TEAM SCORES

1. Camden County.....1,175#
  - DeJesus, Jordan .....297
  - Byrd, Virginia .....293
  - Swain, Abigail .....293
  - Sanford, Skylar .....292
2. Lumpkin County .....1,161
  - Lusky, Liv .....294
  - Moyer, Maddy .....293

- |                     |     |
|---------------------|-----|
| Foster, Brynn ..... | 289 |
| Wright, JT .....    | 285 |

3. East Coweta.....1,152
  - Hicks, Wyatt .....293
  - Carcioppolo, Leonardo .....287
  - Nazario, Destiny .....286
  - Serrano, Theodore .....286

4. Georgia Military College .....1,145
  - Kennedy, Madison.....295
  - Jadol, Natalie .....286
  - Pinter, Gabe .....284
  - Mosayebi, Pouriya .....280

# - New State Record

# STATE SWIMMING RECORDS

## BOYS

| <u>EVENT</u>                    | <u>NAME/YEAR</u>  | <u>SCHOOL/RECORD</u>      |
|---------------------------------|---|---------------------------|
| 200 Yard Medley Relay.....      | Aidan Saunders, Justin Bender, Sebastien Sergile, Caleb Paek.....<br>2022 | Centennial<br>1:31.71     |
| 200 Yard Freestyle.....         | Sebastien Sergile.....<br>2022  | Centennial<br>1:34.05     |
| 200 Yard Individual Medley..... | Henry Bethel.....<br>2021   | Dalton<br>1:45.54         |
| 50 Yard Freestyle.....          | Paul Powers.....<br>2014  | North Hall<br>19.63       |
| 100 Yard Butterfly.....         | Benjamin Irwin.....<br>2023   | *Buford<br>46.94          |
| 100 Yard Freestyle.....         | Paul Powers.....<br>2014  | North Hall<br>43.19       |
| 500 Yard Freestyle.....         | Jake Magahey.....<br>2019   | Mill Creek<br>4:15.63     |
| 100 Yard Backstroke.....        | Michael Taylor.....<br>2017   | Johns Creek<br>45.53      |
| 100 Yard Breaststroke.....      | Henry Bethel.....<br>2021   | Dalton<br>52.96           |
| 200 Yard Freestyle Relay.....   | Brett Sasser, Griffin Egolf, Owen Holland, Jack Aikins.....<br>2021       | West Forsyth<br>1:22.56   |
| 400 Yard Freestyle Relay.....   | Brett Sasser, Griffin Egolf, Owen Holland, Jack Aikins.....<br>2021       | West Forsyth<br>3:03.13   |
| One Meter Diving.....           | Carson Tyler.....<br>2021   | Colquitt County<br>878.95 |

## GIRLS

| <u>EVENT</u>                    | <u>NAME/YEAR</u>  | <u>SCHOOL/RECORD</u>    |
|---------------------------------|---|-------------------------|
| 200 Yard Medley Relay.....      | Sadie Clayton, Katie Christopherson, Gigi Johnson, Annie Jardina.....<br>2021 | Westminster<br>1:40.65  |
| 200 Yard Freestyle.....         | Nicole Stafford.....<br>2013  | Westminster<br>1:45.29  |
| 200 Yard Individual Medley..... | Katie Christopherson.....<br>2022   | Westminster<br>1:56.72  |
| 50 Yard Freestyle.....          | Caitlin Cooper.....<br>2014   | Woodward<br>22.69       |
| 100 Yard Butterfly.....         | Kathleen Hersey.....<br>2008  | Marist<br>52.44         |
| 100 Yard Freestyle.....         | Amanda Weir.....<br>2004  | Brookwood<br>49.06      |
| 500 Yard Freestyle.....         | Elizabeth Hill.....<br>2004   | Westminster<br>4:40.93  |
| 100 Yard Backstroke.....        | Erin Reisinger.....<br>2009   | Walton<br>53.71         |
| 100 Yard Breaststroke.....      | Alicia Henry.....<br>2020   | Alpharetta<br>1:00.56   |
| 200 Yard Freestyle Relay.....   | Gigi Johnson, Janine Horst, Katie Christopherson, Annie Jardina.....<br>2022  | Westminster<br>1:32.56  |
| 400 Yard Freestyle Relay.....   | Gigi Johnson, Sara Ketron, Annie Jardina, Katie Christopherson.....<br>2022   | Westminster<br>3:24.20  |
| One Meter Diving.....           | Ivy Buckley.....<br>2023  | *North Oconee<br>678.65 |

\* New State Record



# STATE TRACK RECORDS

| CLASS 7A - BOYS                      |  |                           |
|--------------------------------------|--|---------------------------|
| <u>EVENT</u>                         | <u>NAME/YEAR</u>   | <u>SCHOOL/RECORD</u>      |
| 100 Meter Dash.....                  | Chris Nelson.....<br>2023  | South Forsyth<br>*10.22   |
| 200 Meter Dash.....                  | Chris Nelson.....<br>2023  | South Forsyth<br>*20.69   |
| 400 Meter Dash.....                  | Njie Sidi.....<br>2023   | Westlake<br>*45.46        |
| 110 Meter High Hurdles .....         | Terrance Trammell.....<br>1996   | Southwest DeKalb<br>13.34 |
| 300 Meter Intermediate Hurdles ..... | William Wynne.....<br>2007   | McEachern<br>35.676       |
| 800 Meter Run .....                  | Marcelo Dunning.....<br>2000   | Campbell<br>1:51.75       |
| 1600 Meter Run .....                 | Ben Hubers.....<br>2007  | McEachern<br>4:07.500     |
| 3200 Meter Run.....                  | Sully Shelton.....<br>2021   | Harrison<br>8:50.85       |
| 400 Meter Relay.....                 | (Avieon Terrell, Sidi Njie, Ji'den Thomas, Antwan Smith).....<br>2023            | Westlake<br>*40.31        |
| 800 Meter Relay.....                 | (Mekhi Stone, Aveion Hayes, Dorian Gibson, Justin Walker).....<br>2022           | Campbell<br>1:25.28       |
| 1600 Meter Relay.....                | (Alexander Knight, Jeremiah Colbert, Ethan Ervin, Ervin Pearson).....<br>2023    | Buford<br>*3:11.24        |
| 3200 Meter Relay.....                | (Tavian Anderson, Ethan Ashley, Hayden Hare, Karthik Kochuparambil).....<br>2021 | Denmark<br>7:44.21        |
| High Jump .....                      | Dothel Edwards.....<br>1983  | Cedar Shoals<br>7'3.5"    |
| Long Jump .....                      | Demar Forbes.....<br>2009  | ML King<br>24'6.5"        |
| Triple Jump.....                     | Nate Cooper.....<br>1975   | Clarke Central<br>51'7.5" |
| Pole Vault.....                      | Brian Hauch.....<br>2019   | Parkview<br>16'6.5"       |
| Shot Put (12 lbs) .....              | Isaiah Rogers.....<br>2016   | Campbell<br>67'10"        |
| Discus (H.S.) .....                  | Antonio Lamar.....<br>2004   | Brookwood<br>197'4"       |

| CLASS 7A - GIRLS                    |   |   |
|-------------------------------------|---|---|
| <u>EVENT</u>                        | <u>NAME/YEAR</u>  | <u>SCHOOL/RECORD</u>                      |
| 100 Meter Dash.....                 | Kaniya Johnson.....<br>2022   | Lowndes<br>11.26                          |
| 200 Meter Dash.....                 | Candace Hill.....<br>2015   | Rockdale County<br>23.05                  |
| 400 Meter Dash.....                 | Kennedy Simon.....<br>2018  | Westlake<br>52.52                         |
| 100 Meter Intermediate Hurdles..... | Tia Jones.....<br>2016  | Walton<br>13.20                           |
| 300 Meter Low Hurdles .....         | Kendell Williams.....<br>2010   | Kell<br>41.30                             |
| 800 Meter Run.....                  | Riley Perlakowski.....<br>2021  | Harrison<br>2:08.11                       |
| 1600 Meter Run .....                | Amanda Winslow.....<br>2009   | Collins Hill<br>4:44.97                   |
| 3200 Meter Run .....                | Lindsey Billings.....<br>2016   | Northview<br>10:21.74                     |
| 400 Meter Relay .....               | (Felicia Brown, Tiffany Camper, Jada Martin, Alexis Smith).....<br>2012           | M.L. King<br>45.69                        |
| 800 Meter Relay.....                | (Serena Tate, Janai Jones, Elle Bass, Madison Campbell).....<br>2023              | Brookwood<br>*1:36.59                     |
| 1600 Meter Relay.....               | (Trinity Hunter, Kaniya Johnson, My'Asia Howard, Kaylan McConnehead).....<br>2022 | Lowndes<br>3:43.29                        |
| 3200 Meter Relay.....               | (Kristal McQueen, Nora Hart, Mary Nesmith, Brooklyn McVicker).....<br>2023        | Marietta<br>*9:18.77                      |
| High Jump .....                     | Nakeitra Jones.....<br>1997   | Northeast<br>5'10.5"                      |
| Long Jump .....                     | Tameisha King.....<br>1999  | Pebblebrook<br>19'10.75"                  |
| Triple Jump.....                    | Julienne McKee.....<br>2002   | Lassiter<br>41'7.75"                      |
| Pole Vault.....                     | Katelyn Utley, Riley Jones, Nicole Counter.....<br>2013, 2022, 2022               | Tift Co., South Forsyth, Denmark<br>12'6" |
| Shot Put (8 lbs. 13 ozs.).....      | Janae Profit.....<br>2021   | Dunwoody<br>47'11.0"                      |
| Discus (2 lbs. 3-1/2 ozs.) .....    | Ronda Gullate.....<br>2002  | Sprayberry<br>154'8"                      |

NOTE: All State Track Records Converted to Metrics - 1985

\* New State Record

# STATE TRACK RECORDS

| <b>CLASS 6A - BOYS</b>               |  |                             |
|--------------------------------------|--|-----------------------------|
| <u>EVENT</u>                         | <u>NAME/YEAR</u>   | <u>SCHOOL/RECORD</u>        |
| 100 Meter Dash.....                  | Maurice Gleaton.....<br>2023   | Hughes<br>*10.14            |
| 200 Meter Dash.....                  | Maurice Gleaton.....<br>2023   | Hughes<br>*20.81            |
| 400 Meter Dash.....                  | Eric Singleton.....<br>2023  | Alexander<br>*46.30         |
| 110 Meter High Hurdles .....         | Terrance Trammell .....  | Southwest DeKalb<br>13.34   |
| 300 Meter Intermediate Hurdles ..... | William Wynne .....  | McEachern<br>35.676         |
| 800 Meter Run .....                  | Marcelo Dunning .....  | Campbell<br>1:51.75         |
| 1600 Meter Run .....                 | Ben Hubers .....   | McEachern<br>4:07.50        |
| 3200 Meter Run .....                 | Tyler Anyan .....  | Brookwood<br>8:52.835       |
| 400 Meter Relay.....                 | (Jaden Barnes, Maurice Gleaton, Dorian Page, Robert Lockhart).....<br>2023   | Hughes<br>*40.55            |
| 800 Meter Relay.....                 | (Deshawn Owens, Carl Murray, Caleb Ramsey, Darius Malcolm, Jr.).....<br>2023 | North Atlanta<br>*1:25.84   |
| 1600 Meter Relay .....               | (Rodney Hooks, Kelly Carter, Hason Graham, Eddie Miller) .....               | Southwest DeKalb<br>3:13.21 |
| 3200 Meter Relay.....                | (Andrew Balogh, Seth Eye, Wes Rountree, Daniel Pierce).....<br>2023          | Etowah<br>*7:53.46          |
| High Jump.....                       | Riyon Rankin.....<br>2023  | Brunswick<br>*7'3.75"       |
| Long Jump.....                       | Amare Hall.....<br>2022  | Carrollton<br>24'9.25"      |
| Triple Jump.....                     | Nate Cooper .....  | Clarke Central<br>51'7.5"   |
| Pole Vault.....                      | Grant Briscoe.....<br>2021   | Carrollton<br>16'2"         |
| Shot Put (12 lbs) .....              | Isaiah Rogers .....  | Campbell<br>67'10"          |
| Discus (H.S.) .....                  | Antonio Lamar .....  | Brookwood<br>197'4"         |

| <b>CLASS 6A - GIRLS</b>             |   |                          |
|-------------------------------------|---|--------------------------|
| <u>EVENT</u>                        | <u>NAME/YEAR</u>  | <u>SCHOOL/RECORD</u>     |
| Long Jump.....                      | Adaejah Hodge.....<br>2022  | Alexander<br>11.33       |
| 200 Meter Dash.....                 | Candace Hill.....<br>2015   | Rockdale County<br>23.05 |
| 400 Meter Dash .....                | Makenzie Dunmore.....<br>2016   | McEachern<br>53.01       |
| 100 Meter Intermediate Hurdles..... | Tia Jones.....<br>2016  | Walton<br>13.20          |
| 300 Meter Low Hurdles.....          | Olivia Powell.....<br>2023  | Woodward<br>*41.26       |
| 800 Meter Run.....                  | Oluwatosin Awoloye.....<br>2023   | South Cobb<br>*2:08.28   |
| 1600 Meter Run .....                | Amanda Winslow .....  | Collins Hill<br>4:44.97  |
| 3200 Meter Run .....                | Lindsey Billings.....<br>2016   | Northview<br>10:21.74    |
| 400 Meter Relay.....                | (Chelsea Williams, Sydney Glee, Kenyah Conner, Olivia Powell).....<br>2023        | Woodward<br>*45.54       |
| 800 Meter Relay.....                | (Makai August, Madison Williams-Zachery, Kenyah Conner, Savy Seward).....<br>2023 | Woodward<br>*1:39.08     |
| 1600 Meter Relay.....               | (Makenzie Dunmore, Cierra Dunston, Shania Evans, Kristin Hall).....<br>2014       | McEachern<br>3:44.59     |
| 3200 Meter Relay.....               | (Ella Stone, Lane Boyle, Hannah Schemmel, Zoe Garcia).....<br>2023                | St. Pius<br>*9:21.48     |
| High Jump .....                     | Nakeitra Jones .....  | Northeast<br>5'10.5"     |
| Long Jump.....                      | Adaejah Hodge.....<br>2022  | Alexander<br>20'4.25"    |
| Triple Jump.....                    | Alisa Gordon.....<br>2023   | Alexander<br>*41'9.5"    |
| Pole Vault.....                     | Payton Phillips.....<br>2021  | Carrollton<br>13'5.5"    |
| Shot Put (8 lbs. 13 ozs.) .....     | Ashley Johnson .....  | Westlake<br>47'3.5"      |
| Discus (2 lbs. 3-1/2 ozs.) .....    | Ronda Gullate .....   | Sprayberry<br>154'8"     |

NOTE: All State Track Records Converted to Metrics - 1985

\* New State Record

# STATE TRACK RECORDS

| <b>CLASS 5A - BOYS</b>  |  |                             |
|---|--|-----------------------------|
| <u>EVENT</u>  | <u>NAME/YEAR</u>   | <u>SCHOOL/RECORD</u>        |
| 100 Meter Dash.....   | Ryan Clark<br>2015   | Banneker<br>10.26           |
| 200 Meter Dash.....   | Ryan Clark<br>2015   | Banneker<br>20.79           |
| 400 Meter Dash.....   | Trey Johnson<br>2018   | Fayette County<br>46.37     |
| 110 Meter High Hurdles .....  | Terrance Trammell<br>1996  | Southwest DeKalb<br>13.34   |
| 300 Meter Intermediate Hurdles .....  | William Wynne<br>2007  | McEachern<br>35.676         |
| 800 Meter Run .....   | Marcelo Dunning<br>2000  | Campbell<br>1:51.75         |
| 1600 Meter Run .....  | Ben Hubers<br>2007   | McEachern<br>4:07.50        |
| 3200 Meter Run .....  | Tyler Anyan<br>2010  | Brookwood<br>8:52.835       |
| 400 Meter Relay.....(Angelo Taylor, Aurbir Richard, Clint Crenshaw, Terrance Trammell)..... |  | Southwest DeKalb<br>40.66   |
| 800 Meter Relay.....(Kenneth Robbins, Xzaviah Taylor, Xavier Turner, Ali Dargan).....       |  | Southwest DeKalb<br>1:25.19 |
| 1600 Meter Relay .....  | (Jordan Billingslea, Ryan Clark, Bobby Johnson, Kden Johnson)..... | Banneker<br>3:12.03         |
| 3200 Meter Relay.....(Zack Burke, Loden Kohrman, Isaac Soricelli, Clark Bilderback).....    |  | Blessed Trinity<br>7:53.54  |
| High Jump .....   | Dothel Edwards<br>1983   | Cedar Shoals<br>7'3.5"      |
| Long Jump.....  | Jaylan Harris<br>2022  | Calhoun<br>24'7"            |
| Triple Jump.....  | Nate Cooper<br>1975  | Clarke Central<br>51'7.5"   |
| Pole Vault.....   | Tray Oates<br>2013   | Allatoona<br>16'1"          |
| Shot Put (12 lbs) .....   | Chip Kell<br>1966  | Avondale<br>66'7"           |
| Discus (H.S.) .....   | Antonio Lamar<br>2004  | Brookwood<br>197'4"         |

| <b>CLASS 5A - GIRLS</b>   |                          |                              |
|---|--------------------------|------------------------------|
| <u>EVENT</u>  | <u>NAME/YEAR</u>         | <u>SCHOOL/RECORD</u>         |
| 100 Meter Dash .....  | Cassandra Hall<br>2016   | Warner Robins<br>11.43       |
| 200 Meter Dash.....   | Trinity Price<br>2018    | Buford<br>23.58              |
| 400 Meter Dash.....   | Kimberly Harris<br>2019  | Buford<br>53.28              |
| 100 Meter Intermediate Hurdles .....  | Kendell Williams<br>2013 | Kell<br>13.23                |
| 300 Meter Low Hurdles .....   | Kendell Williams<br>2010 | Kell<br>41.30                |
| 800 Meter Run .....   | Brittany Hall<br>2006    | Meadowcreek<br>2:08.58       |
| 1600 Meter Run .....  | Amanda Winslow<br>2009   | Collins Hill<br>4:44.97      |
| 3200 Meter Run.....   | Hannah Schemmel<br>2021  | St. Pius X<br>10:25.72       |
| 400 Meter Relay.....(Trinity Price, Alexa Rossum, Trinity Rossum, Kimberly Harris).....             |                          | Buford<br>45.17              |
| 800 Meter Relay.....(Mckenzie Burnett, Alyssa Crump, Insiya Magee, Jori Savage).....                |                          | Heritage-Conyers<br>*1:38.57 |
| 1600 Meter Relay.....(Trinity Price, Trinity Rossum, Kimberly Harris, Britiney Johnson).....        |                          | Buford<br>3:44.28            |
| 3200 Meter Relay.....(Emma Jacobs, Katherine Hamfeldt, Claire Petersen, Kelly Ann Sutterfield)..... |                          | Blessed Trinity<br>9:23.38   |
| High Jump .....   | Nakeitra Jones<br>1997   | Northeast<br>5'10.5"         |
| Long Jump .....   | Kendell Williams<br>2013 | Kell<br>20'9.75"             |
| Triple Jump.....  | Bria Matthews<br>2015    | Forest Park<br>43'5.5"       |
| Pole Vault.....   | Payton Phillips<br>2019  | Carrollton<br>13'2.25"       |
| Shot Put (8 lbs. 13 ozs.).....  | Ashley Johnson<br>2011   | Westlake<br>47'3.5"          |
| Discus (2 lbs. 3-1/2 ozs.).....   | Ronda Gullate<br>2002    | Sprayberry<br>154'8"         |

NOTE: All State Track Records Converted to Metrics - 1985

\* New State Record

# STATE TRACK RECORDS

| <b>CLASS 4A - BOYS</b>              |   |                      |
|-------------------------------------|---|----------------------|
| <u>EVENT</u>                        | <u>NAME/YEAR</u>  | <u>SCHOOL/RECORD</u> |
| 100 Meter Dash .....                | Dangelo Cherry .....  | Mt. Zion-Jonesboro   |
|                                     | 2008  | 10.33                |
| 200 Meter Dash.....                 | Ali Dargan .....  | Miller Grove         |
|                                     | 2023  | *20.86               |
| 400 Meter Dash .....                | Michael Newton .....  | Sprayberry           |
|                                     | 2012  | 46.62                |
| 110 Meter High Hurdles .....        | Terrance Trammell .....   | Southwest DeKalb     |
|                                     | 1996  | 13.34                |
| 300 Meter Intermediate Hurdles..... | Isaiah Taylor.....  | Southwest DeKalb     |
|                                     | 2023  | *35.94               |
| 800 Meter Run .....                 | Marcelo Dunning .....   | Campbell             |
|                                     | 2000  | 1:51.75              |
| 1600 Meter Run.....                 | Joe Sapone.....   | Holy Innocents'      |
|                                     | 2023  | *4:04.27             |
| 3200 Meter Run .....                | Willie Nelson, Travis Grindstaff.....   | LaGrange, Etowah     |
|                                     | 1975, 1988  | 9:04.7               |
| 400 Meter Relay .....               | (Kendrick Ings, Johnathan Norris, Kenneth Gilstrap, Antione Hightower).....   | Miller Grove         |
|                                     | 2009 (prelims)  | 40.64                |
| 800 Meter Relay.....                | (Taylor Anderson, Xzaviah Taylor, Xavier Turner, Therrian Alexander III)..... | Southwest DeKalb     |
|                                     | 2023  | *1:25.13             |
| 1600 Meter Relay.....               | (Therrian Alexander III, Isaiah Taylor, Xzaviah Taylor, Xavier Turner).....   | Southwest DeKalb     |
|                                     | 2023  | *3:10.55             |
| 3200 Meter Relay.....               | (Esfan Daya, Rohan Gazula, Joseph Jacquot, Willem Mandel).....                | Westminster          |
|                                     | 2023  | *8:00.00             |
| High Jump .....                     | Dothel Edwards .....  | Cedar Shoals         |
|                                     | 1983  | 7'3.5"               |
| Long Jump .....                     | Stephen Hill .....  | Miller Grove         |
|                                     | 2009  | 25'8.75"             |
| Triple Jump .....                   | Nate Cooper .....   | Clarke Central       |
|                                     | 1975  | 51'7.5"              |
| Pole Vault.....                     | Tyler Craig .....   | Pickens              |
|                                     | 2013  | 15'7"                |
| Shot Put (12 lbs.).....             | Tanner Duffin.....  | St. Pius             |
|                                     | 2019  | 66'10.5"             |
| Discus (H.S.).....                  | Tanner Duffin.....  | St. Pius             |
|                                     | 2018  | 189'3"               |

| <b>CLASS 4A - GIRLS</b>              |   |                      |
|--------------------------------------|---|----------------------|
| <u>EVENT</u>                         | <u>NAME/YEAR</u>  | <u>SCHOOL/RECORD</u> |
| 100 Meter Dash.....                  | Sanaa Frederick.....  | Druid Hills          |
|                                      | 2023  | *11.41               |
| 200 Meter Dash.....                  | Sanaa Frederick.....  | Druid Hills          |
|                                      | 2023  | *23.39               |
| 400 Meter Dash .....                 | Stephanie Smith .....   | Northeast, Macon     |
|                                      | 2000  | 53.65                |
| 100 Meter Intermediate Hurdles ..... | Kendell Williams .....  | Kell                 |
|                                      | 2012  | 13.39                |
| 300 Meter Low Hurdles.....           | Chastity Pickett.....   | Westover             |
|                                      | 2019  | 42.03                |
| 800 Meter Run .....                  | Ena Leufroy .....   | Marist               |
|                                      | 2005  | 2:08.643             |
| 1600 Meter Run .....                 | Emily Reese .....   | Chamblee             |
|                                      | 2006  | 4:52.245             |
| 3200 Meter Run .....                 | Morgan Ilse .....   | Marist               |
|                                      | 2015  | 10:25.39             |
| 400 Meter Relay.....                 | (Jadyn Bolden, Miya Carthan, Sanaa Frederick, Sole Frederick).....    | Druid Hills          |
|                                      | 2023  | *45.74               |
| 800 Meter Relay.....                 | (Kirah Copeland, Monika Demps, Kennedi Bryan, Jayla Lee).....         | Stockbridge          |
|                                      | 2023  | *1:40.21             |
| 1600 Meter Relay .....               | (Ashley Taylor, Marcia Smith, Henrietta George, Kelsey Woodard) ..... | Stephenson           |
|                                      | 1999  | 3:45.55              |
| 3200 Meter Relay.....                | (Harriet Blaha, Zahara Bernal, Caroline Hood, Olivia Resnick).....    | Pace Academy         |
|                                      | 2023  | *9:27.36             |
| High Jump .....                      | Nakeitra Jones .....  | Northeast            |
|                                      | 1997  | 5'10.5"              |
| Long Jump .....                      | Kendell Williams .....  | Kell                 |
|                                      | 2012  | 20'8.5"              |
| Triple Jump .....                    | Tyeisha Juhan.....  | Mt. Zion-Jones.      |
|                                      | 2016  | 40'4.25"             |
| Pole Vault.....                      | Olivia Moore.....   | Pickens              |
|                                      | 2018  | 13'7"                |
| Shot Put (8 lbs. 13 ozs.).....       | Noelle Parker.....  | Whitewater           |
|                                      | 2015  | 46'9.5"              |
| Discus (2 lbs. 3-1/2 ozs.) .....     | Eve Machovec .....  | Dacula               |
|                                      | 2008  | 148'9"               |

NOTE: All State Track Records Converted to Metrics - 1985

\* New State Record

# STATE TRACK RECORDS

| <b>CLASS 3A - BOYS</b>               |  |                           |
|--------------------------------------|--|---------------------------|
| <u>EVENT</u>                         | <u>NAME/YEAR</u>   | <u>SCHOOL/RECORD</u>      |
| 100 Meter Dash.....                  | Japheth Morris.....<br>2017  | Appling County<br>10.41   |
| 200 Meter Dash.....                  | Howard Adams.....<br>1962  | Rossville<br>21.1         |
| 400 Meter Dash .....                 | Christian Taylor .....   | Sandy Creek<br>46.60      |
| 110 Meter High Hurdles .....         | Dexter Hawkins .....   | West Fulton<br>13.6       |
| 300 Meter Intermediate Hurdles ..... | Tim Grier .....  | Westlake<br>36.74         |
| 800 Meter Run .....                  | Brendon Mahoney .....  | Marist<br>1:50.17         |
| 1600 Meter Run.....                  | Matthew Fernando.....<br>2022  | Westminster<br>4:11.61    |
| 3200 Meter Run.....                  | Justin Wachtel.....<br>2021  | Mary Persons<br>9:06.49   |
| 400 Meter Relay.....                 | (Stanley Heller, Jamal Sailem, Keelan Crosby, Japheth Morris).....<br>2017 | Appling County<br>41.11   |
| 800 Meter Relay.....                 | (Zavion Green, Geimere Latimer, Kyshon Kenney, Cameron Watts).....<br>2023 | Sandy Creek<br>*1:27.44   |
| 1600 Meter Relay .....               | (Tamaric Johnson, Fred Scott, Korey Bryant, Aaron Sibley) .....            | Stone Mountain<br>3:15.28 |
| 3200 Meter Relay.....                | (Jack Ramsey, Ryan Githubu, Matthew Propp, Matthew Fernando).....<br>2021  | Westminster<br>7:55.84    |
| High Jump .....                      | Thaddeus Hood.....<br>1992   | Glenn Hills<br>7'2"       |
| Long Jump.....                       | Christian Taylor.....<br>2008  | Sandy Creek<br>25'6"      |
| Triple Jump.....                     | Christian Taylor.....<br>2008  | Sandy Creek<br>52'6.5"    |
| Pole Vault.....                      | Paul Malquist .....  | Gainesville<br>16'8"      |
| Shot Put (12 lbs).....               | Kurt Quartermann.....<br>2002  | Westover<br>63'0.75"      |
| Discus (H.S.) .....                  | Hiawatha Berry .....   | Winder-Barrow<br>197'10"  |

| <b>CLASS 3A - GIRLS</b>             |   |                               |
|-------------------------------------|---|-------------------------------|
| <u>EVENT</u>                        | <u>NAME/YEAR</u>  | <u>SCHOOL/RECORD</u>          |
| 100 Meter Dash .....                | Brittany Long.....<br>2007  | Therrell<br>11.429            |
| 200 Meter Dash .....                | Brittany Long.....<br>2007  | Therrell<br>23.306            |
| 400 Meter Dash .....                | Stephanie Smith .....   | Northeast<br>53.084           |
| 100 Meter Intermediate Hurdles..... | Jasmine Jones.....<br>2018  | GACS<br>13.77                 |
| 300 Meter Low Hurdles.....          | Marianna Wright.....<br>2023  | Monroe<br>*40.81              |
| 800 Meter Run.....                  | Isis Symone Grant.....<br>2023  | Sandy Creek<br>*2:10.09       |
| 1600 Meter Run .....                | Emily Reese .....   | Chamblee<br>4:48.514          |
| 3200 Meter Run .....                | Emily Reese .....   | Chamblee<br>10:16.762         |
| 400 Meter Relay.....                | (Nia Brown, Chloe Fair, Jada Jones, Jasmine Jones).....<br>2018   | GACS<br>45.73                 |
| 800 Meter Relay.....                | (Eve Craig, Marianna Wright, Kaitlyn Williams, Jurdyn Johnson).....<br>2023                             | Monroe<br>*1:41.74            |
| 1600 Meter Relay.....               | (Deanna Lee, Santeria Moses, Jawanda King, Brittany Long, Malaysia Puckett, Tiffany Ellis).....<br>2007 | Therrell<br>3:47.264          |
| 3200 Meter Relay.....               | (Janie Cooper, Cate Stevens, Alexandra Lalli, Palmer Walstad).....<br>2022                              | Westminster<br>9:27.56        |
| High Jump .....                     | Tracey Linton .....   | Central, Thomasville<br>5'10" |
| Long Jump.....                      | Jasmine Jones.....<br>2019  | GACS<br>20'2.25"              |
| Triple Jump.....                    | Chelsea Davis.....<br>2022  | Sandy Creek<br>40'10"         |
| Pole Vault.....                     | Amelia Johnson.....<br>2023   | Hart County<br>*13'0"         |
| Shot Put (8 lbs. 13 ozs.) .....     | April Thomas .....  | Westover<br>46'7"             |
| Discus (2 lbs. 3-1/2 ozs.).....     | Leia Williams.....<br>2022  | Liberty County<br>151'10"     |

NOTE: All State Track Records Converted to Metrics - 1985

\* New State Record

# STATE TRACK RECORDS

| <b>CLASS 2A - BOYS</b>   |   |                          |
|--|---|--------------------------|
| <u>EVENT</u>   | <u>NAME/YEAR</u>  | <u>SCHOOL/RECORD</u>     |
| 100 Meter Dash .....   | Justin Scott-Wesley<br>2010                                       | Mitchell County<br>10.35 |
| 200 Meter Dash .....   | Antonio McKay<br>1982   | Roosevelt<br>21.4        |
| 400 Meter Dash .....   | Antonio McKay<br>1982   | Roosevelt<br>46.98       |
| 110 Meter High Hurdles .....   | Roger Kingdom<br>1981   | Vienna<br>13.7           |
| 300 Meter Intermediate Hurdles .....   | Jamal Patterson<br>2009 (prelims)                                 | Henry County<br>36.82    |
| 800 Meter Run .....  | Ian Scott<br>1998   | Lovett<br>1:52.77        |
| 1600 Meter Run .....   | Ralph King<br>1974  | St. Pius X<br>4:05.3     |
| 3200 Meter Run .....   | Ralph King<br>1974  | St. Pius X<br>8:52.5     |
| 400 Meter Relay.....(Isarel Meggett, Eric White, Jr., Simeon Adams, Taj Price).....        | 2023  | Drew Charter<br>*41.31   |
| 800 Meter Relay.....(Quindarius Warren, KeShawn Wiley, Kameran Warren, Jordan Turner)..... | 2023  | Washington<br>*1:27.97   |
| 1600 Meter Relay .....   | (Warren Ward, Melvin Buford, Richard Dukes, Allen Buford)<br>1979 | Lakeshore<br>3:16.00     |
| 3200 Meter Relay.....(Edward Blaha, George Blaha, Robert Mallis, Grant Thompson).....      | 2022  | Pace Academy<br>8:02.75  |
| High Jump .....  | Maalik Reynolds<br>2010   | Westminster<br>7'2"      |
| Long Jump .....  | Reggie Brown<br>1997  | Carrollton<br>24'9"      |
| Triple Jump .....  | Javian Williams<br>2016   | Early County<br>49'4.5"  |
| Pole Vault .....   | Tyler Porter<br>2010  | Jefferson<br>16'7.25"    |
| Shot Put (12 lbs.) .....   | Adam Nelson<br>1993   | Lovett<br>59'7"          |
| Discus (H.S.) .....  | LB Joel<br>2009   | Westminster<br>177'9"    |

| <b>CLASS 2A - GIRLS</b>  |  |                              |
|--|--|------------------------------|
| <u>EVENT</u>   | <u>NAME/YEAR</u>   | <u>SCHOOL/RECORD</u>         |
| 100 Meter Dash.....  | Madeline Cooper<br>2023  | Drew Charter<br>*11.71       |
| 200 Meter Dash.....  | Taylor DeLoach<br>2016   | St. Vincent's<br>23.88       |
| 400 Meter Dash.....  | Victoria Powell<br>2016  | Lovett<br>53.94              |
| 100 Meter Intermediate Hurdles.....  | Madeline Cooper<br>2023  | Drew Charter<br>*13.93       |
| 300 Meter Low Hurdles.....   | Chelsea Zolleer<br>2016  | Holy Innocents'<br>42.78     |
| 800 Meter Run .....  | Georgia Kloss<br>2002  | Pace Academy<br>2:09.478     |
| 1600 Meter Run .....   | Georgia Kloss<br>2003  | Pace Academy<br>4:58.87      |
| 3200 Meter Run.....  | Serena Tripodi<br>2015   | Lovett<br>10:54.15           |
| 400 Meter Relay .....  | (Brittany Arnold, Airica Palmer, Maileka Slayton, Kayin Mujahid)<br>2012 | GACS<br>47.31                |
| 800 Meter Relay.....(Jasmine Holmes, Perry Mitchell, Teandra Clemons, Cadence Cray).....         | 2023   | Appling County<br>*1:41.37   |
| 1600 Meter Relay .....   | (Brittany Arnold, Airica Palmer, Maileka Slayton, Kayin Mujahid)<br>2012 | GACS<br>3:51.46              |
| 3200 Meter Relay.....(Lizzie Wadsworth, Maddie Williams, Katie Wadsworth, Ella Stoudenmire)..... | 2021   | Oglethorpe County<br>9:34.14 |
| High Jump .....  | Brandy Barnett<br>1996   | Coosa<br>5'8"                |
| Long Jump.....   | Taylor DeLoach<br>2016   | St. Vincent's<br>20'5.25"    |
| Triple Jump .....  | Antqunita Reed<br>2010   | Early County<br>40'1"        |
| Pole Vault.....  | Sydney Rodkey<br>2012  | North Oconee<br>12'1"        |
| Shot Put (8 lbs. 13 ozs.).....   | Danisha Jones<br>2015  | Thomasville<br>44'11"        |
| Discus (2 lbs. 3-1/2 ozs.).....  | Shelby Speed<br>2023   | Banks County<br>*153'1"      |

NOTE: All State Track Records Converted to Metrics - 1985

\* New State Record

# STATE TRACK RECORDS

| <b>CLASS A - BOYS</b>                |   |                               |
|--------------------------------------|---|-------------------------------|
| <u>EVENT</u>                         | <u>NAME/YEAR</u>  | <u>SCHOOL/RECORD</u>          |
| 100 Meter Dash.....                  | Christian Coleman.....<br>2014  | Our Lady of Mercy<br>10.38    |
| 200 Meter Dash.....                  | Christian Coleman.....<br>2014  | Our Lady of Mercy<br>21.10    |
| 400 Meter Dash .....                 | Ecardo Odom .....   | Dooly County<br>47.67         |
| 110 Meter High Hurdles .....         | Kenny Selmon.....<br>2014   | Pace Academy<br>13.96         |
| 300 Meter Intermediate Hurdles ..... | Kenny Selmon.....<br>2014   | Pace Academy<br>37.21         |
| 800 Meter Run .....                  | O'Neal Wanliss .....  | Holy Innocents'<br>1:49.618   |
| 1600 Meter Run .....                 | Henry Dwyer .....   | Athens Academy<br>4:10.84     |
| 3200 Meter Run.....                  | Graham Blanks.....<br>2019  | Athens Academy<br>9:13.93     |
| 400 Meter Relay.....                 | (Nate McCollum, Justin Menard, Khaleb Hood, Keaton Mitchell).....<br>2018       | ELCA<br>41.43                 |
| 800 Meter Relay.....                 | (Trevor Strowbridge, Buddy Gary, Donovan Johnson, Garrhet Manning).....<br>2022 | Calvary Day<br>1:27.94        |
| 1600 Meter Relay.....                | (Richard Jubinor, Josiah Brooks, Justin Brooks, Demarcus Evans).....<br>2015    | Athens Christian<br>3:20.08   |
| 3200 Meter Relay.....                | (Johann Brink, Eli Vaughn, Nathan Smith, Thrasher Wilkins).....<br>2023         | Athens Christian<br>* 8:05.43 |
| High Jump .....                      | Raymond Higgs .....   | Athens Christian<br>7'2.25"   |
| Long Jump .....                      | Raymond Higgs .....   | Athens Christian<br>24'4"     |
| Triple Jump.....                     | Joshua Smith.....<br>2021   | Landmark Christian<br>48'9.5" |
| Pole Vault.....                      | Brenden Vanderpool.....<br>2022   | Whitefield Academy<br>15'2"   |
| Shot Put (12 lbs).....               | LenNeth Whitehead.....<br>2018  | Athens Academy<br>66'4.5"     |
| Discus (H. S.) .....                 | Jordan Pickerel.....<br>2013  | Athens Christian<br>168'1"    |

| <b>CLASS A - GIRLS</b>               |  |                                  |
|--------------------------------------|--|----------------------------------|
| <u>EVENT</u>                         | <u>NAME/YEAR</u>   | <u>SCHOOL/RECORD</u>             |
| 100 Meter Dash.....                  | T'Aja Cameron.....<br>2016   | ELCA<br>11.74                    |
| 200 Meter Dash.....                  | T'Aja Cameron.....<br>2016   | ELCA<br>24.32                    |
| 400 Meter Dash.....                  | Malia Campbell.....<br>2022  | Landmark Christian<br>55.49      |
| 100 Meter Intermediate Hurdles ..... | Sierra Hill .....  | Landmark Christian<br>13.34      |
| 300 Meter Low Hurdles .....          | Sierra Hill .....  | Landmark Christian<br>43.06      |
| 800 Meter Run.....                   | Anna Marian Block.....<br>2016   | Athens Academy<br>2:10.82        |
| 1600 Meter Run.....                  | Anna Marian Block.....<br>2016   | Athens Academy<br>4:51.28        |
| 3200 Meter Run.....                  | Emma Grace Hurley.....<br>2016   | Fellowship Christian<br>10:33.23 |
| 400 Meter Relay .....                | (Evette Holyfield, Ciara Willis, Lynette Fitts, Sierra Hill) .....                         | Landmark Christian<br>47.54      |
| 800 Meter Run.....                   | (Hope Clerk, MiAngel Allrich, Cristiana Chachere, Malia Campbell).....<br>2022             | Landmark Christian<br>1:42.19    |
| 1600 Meter Relay .....               | (Lynette Fitts, Evette Holyfield, Ciara Willis, Sierra Hill) .....                         | Landmark Christian<br>3:50.20    |
| 3200 Meter Relay.....                | (Addison Ollendick-Smith, Sarah Harrison, Nathalie Lavender, Davis McLanahan).....<br>2021 | Athens Academy<br>9:36.81        |
| High Jump .....                      | Jessica Farrer .....   | Model<br>5'10.25"                |
| Long Jump.....                       | Synclair Savage.....<br>1991   | North Cobb Christian<br>19'3.50" |
| Triple Jump.....                     | Jasmine Akins.....<br>2019   | Calvary Day<br>39'10.50"         |
| Pole Vault.....                      | Becky Arbiv.....<br>2017   | The Weber School<br>13'6.5"      |
| Shot Put (8 lbs. 13 ozs.).....       | Torie Owers .....  | Athens Academy<br>46'8.5"        |
| Discus (2 lbs. 3-1/2 ozs.) .....     | Torie Owers .....  | Athens Academy<br>154'8"         |

NOTE: All State Track Records Converted to Metrics - 1985

\* New State Record